

# Test fuselage plans

## Part 1 – Cutting plans

The following drawings are meant to guide the cutting of the foam parts for the aircraft..

The materials chosen are EPS (styrofoam) for the main wing, to allow for the cutting of the wing profile, and XPS foam (the kind used for architectural maquettes) for the fuselage, for strength and lightness. The EPS should be min 3cm thick to allow for the full profile cut.

The longest cut taken is ~30 cm, so the hot wire should be at least that long plus the thickness of the profile forms.

**Author: 0x16**

**Date: 7/6/16**

**Document Version : 1.4**

**Number of Pages: 7**

The full text and content of this document is licensed under the Creative Commons Attribution License (CC-BY), giving permission for free use, redistribution, copy and modification provided the original author of this document is credited as such.

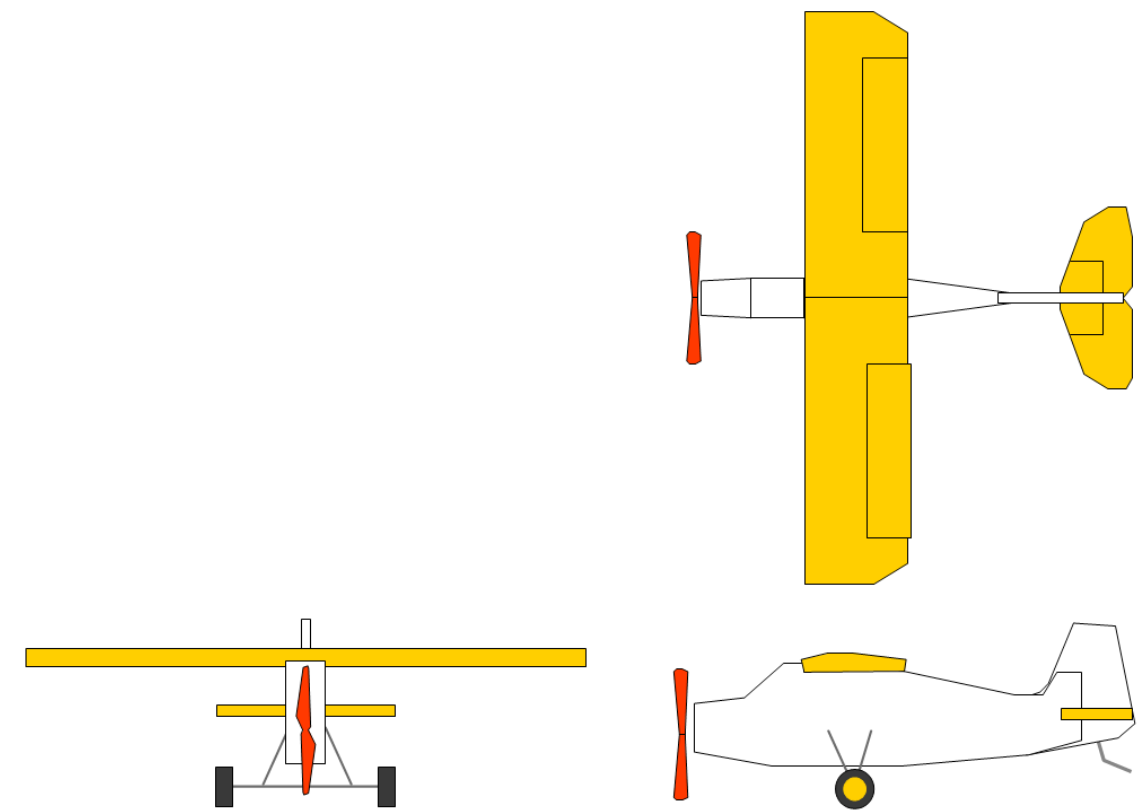

Main wing – 1 side

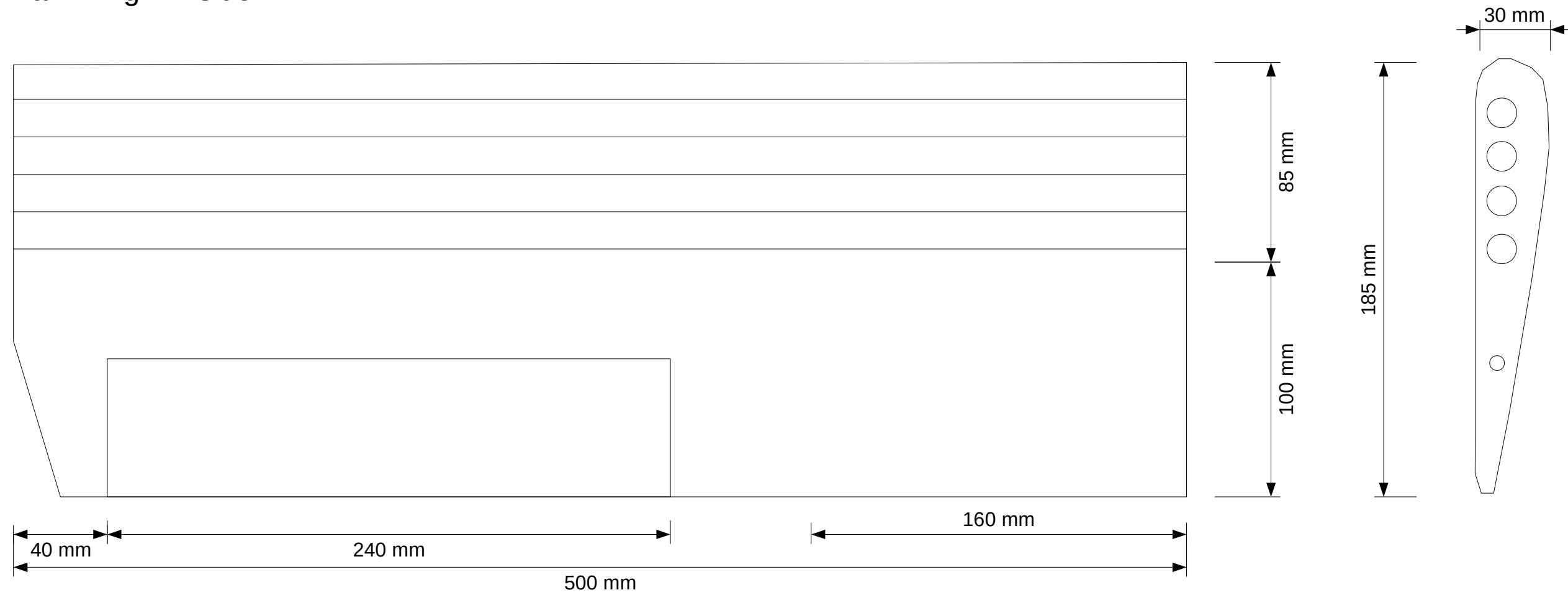

Tail wing

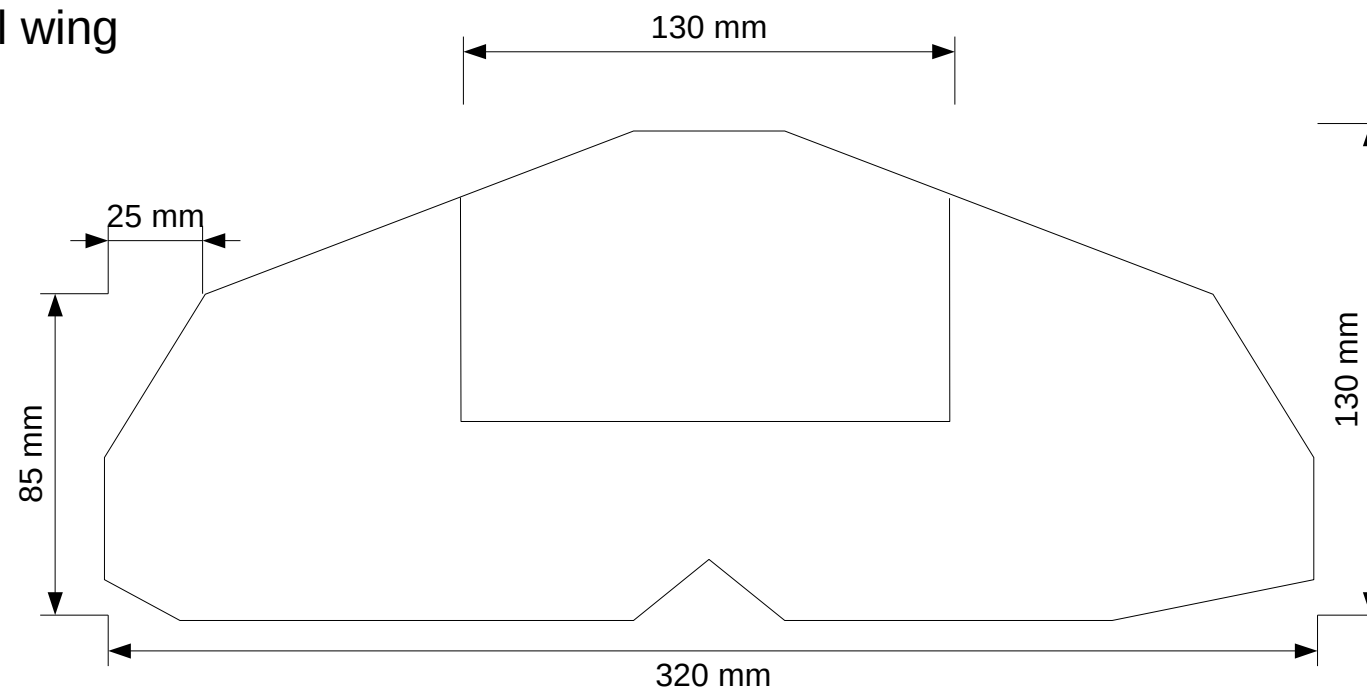

**Author:** 0x16  
**Title:** Test fuselage plan  
**Page:** 2 of 7 – Wings  
**Scale:** 1:2  
**Date:** 7/6/16  
**License:** CC-BY

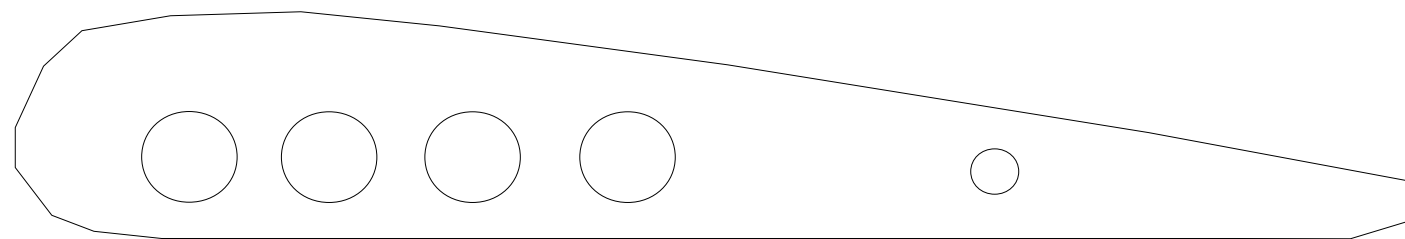

**Author:** 0x16  
**Title:** Test fuselage plan  
**Page:** 3 of 7 – wing profile detail  
**Scale:** 1:1  
**Version :** 1.4  
**Date:**7/6/16  
**License:** CC-BY

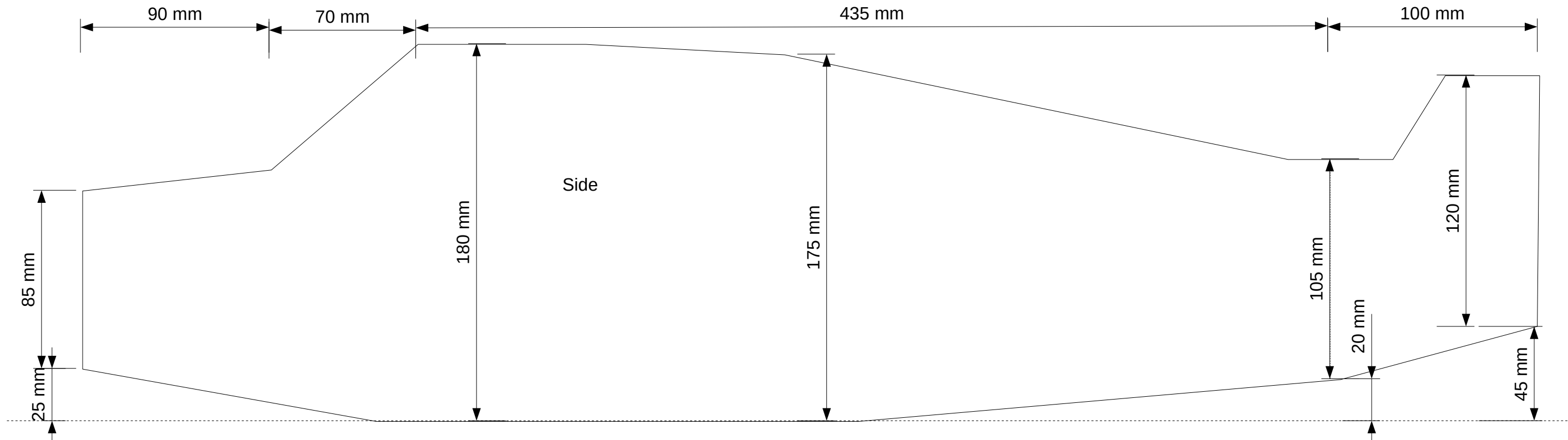
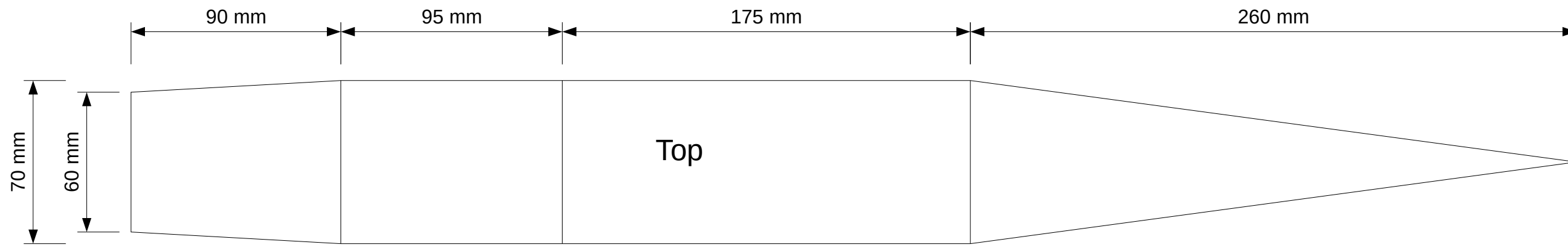

**Author:** 0x16  
**Title:** Test fuselage plan  
**Page:** 4 of 7 – Fuselage  
**Scale:** 1:2  
**Date:** 7/6/16  
**License:** CC-BY

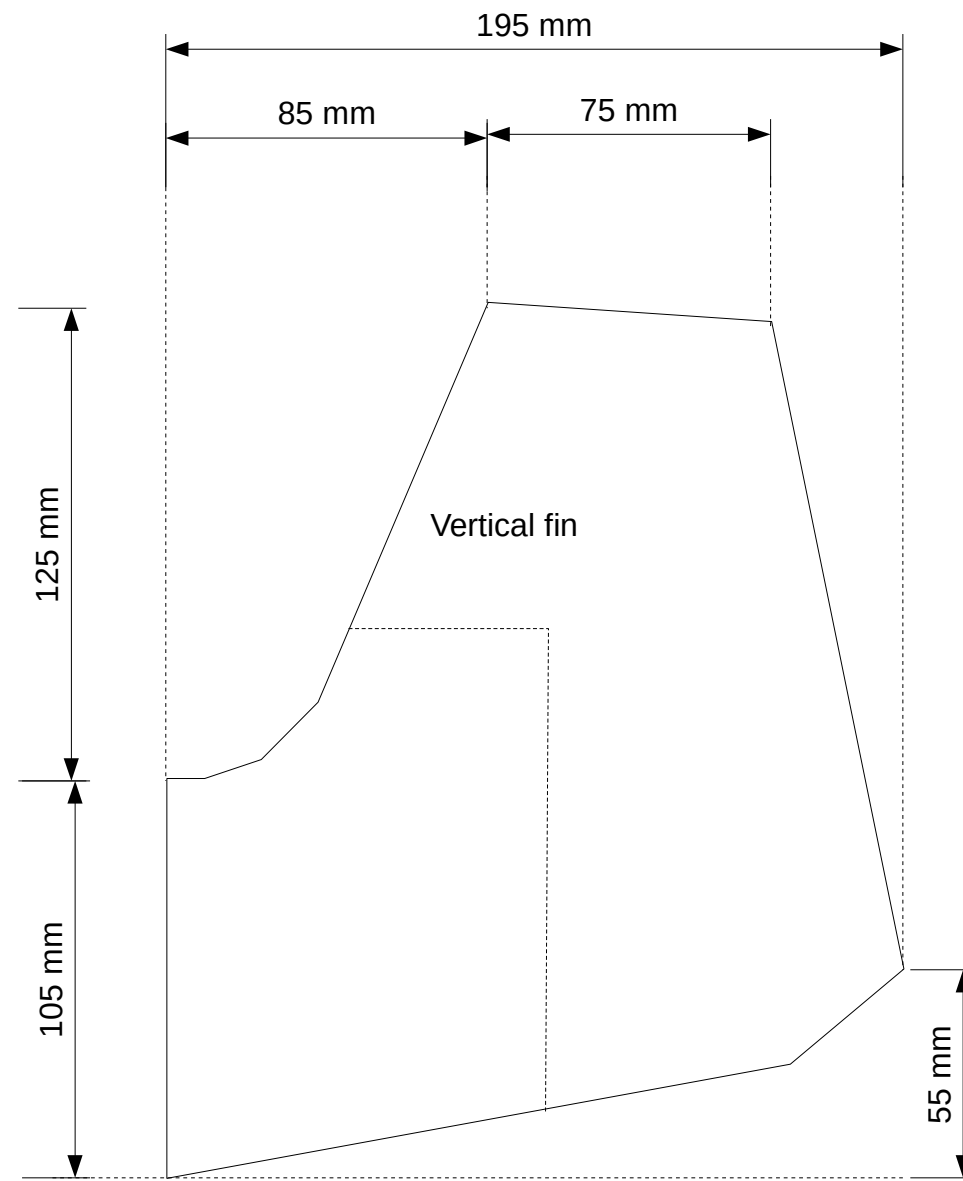

# Test fuselage plans

## Part 2 – Assembly plans

The following drawings are meant to guide the assembly of the aircraft.

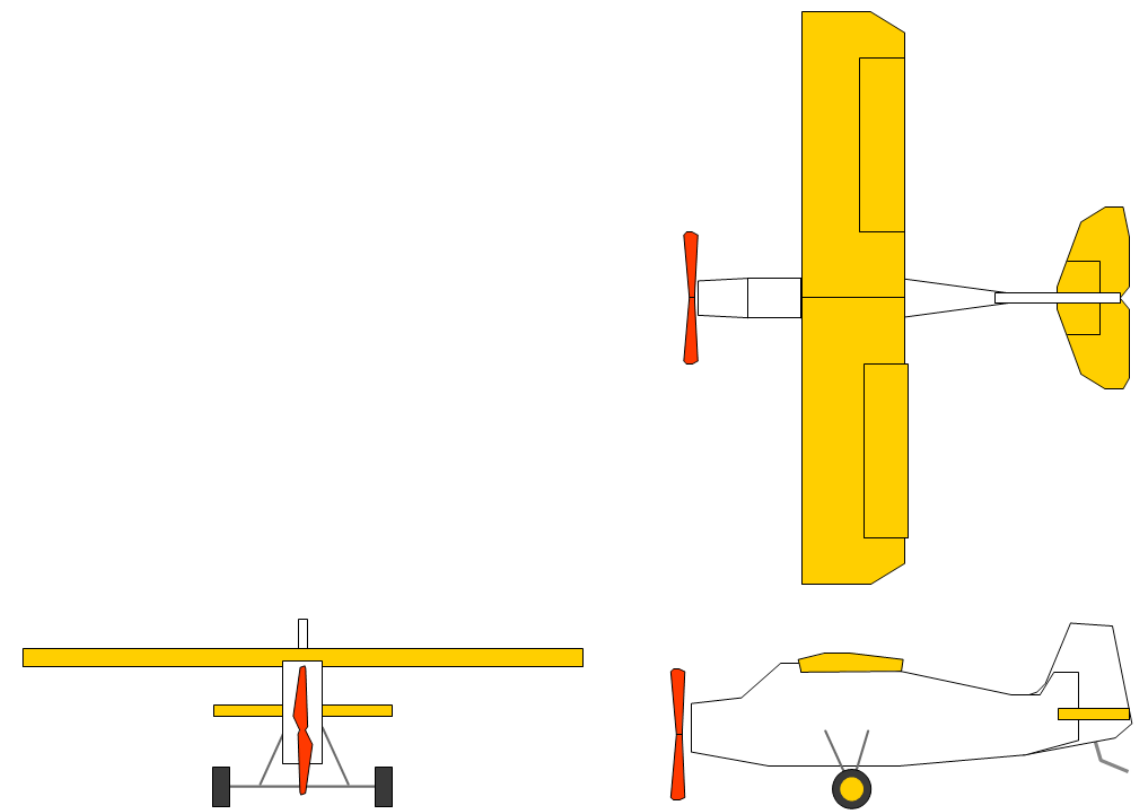

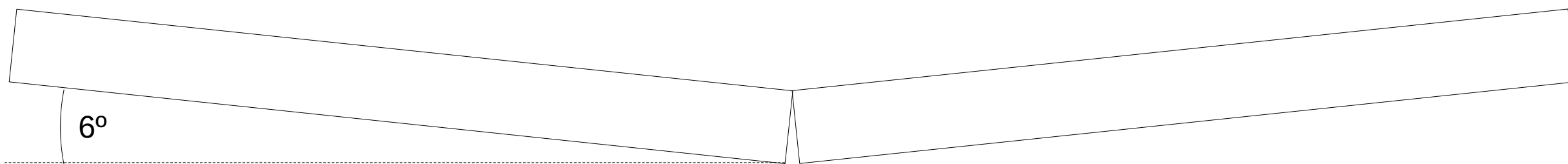

**Author:** 0x16  
**Title:** Test fuselage plan  
**Page:** 7 of 7 – Main wing Assembly  
**Scale:** NA  
**Date:** 7/6/16  
**License:** CC-BY