

SUPER
VEXTA[®]

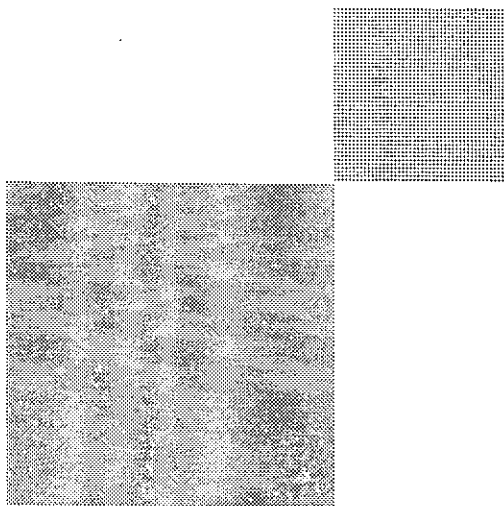

Operating Manual

Constant Current Driver for 2 Phase Stepping Motors

UD2115



1. Verifying the product name and accessories

- Please confirm that driver and accessories are included before using the driver.

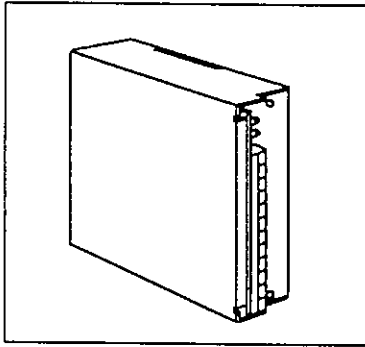

Driver



Operating Manual

- Check for any damage that may have occurred during shipment. If any problems are found, please contact nearest ORIENTAL MOTOR.

2. Features

- High performance constant current driver in a compact and slim-line body.
- Full step (1.8°/step) and half step (0.9°/step) selectable.
- Optically isolated signal input by photocoupler for high noise immunity.
- Equips with an *Automatic Current Cutback at Motor Standstill* function to suppress heat generation when the motor is stopped.
- Two types of pulse input mode selectable.

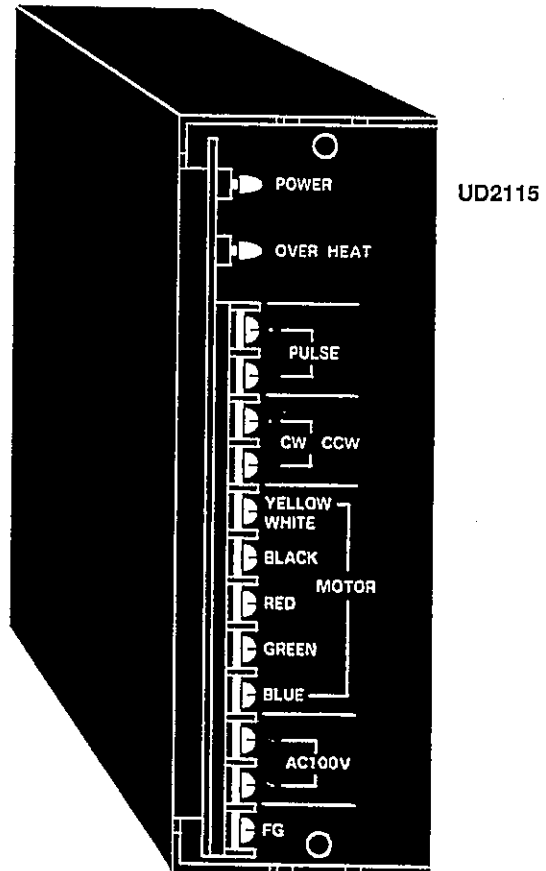

•Applicable Motor

Motor Model		Motor Operating Current A/total
Single Shaft	Double Shaft	
PH264-01	PH264-01B	2.2
PH265-01	PH265-01B	1.7
PH266-01	PH266-01B	2.4
PH268-01	PH268-01B	3.0
PH268-21	PH268-21B	3.0
PH296-02	PH296-02B	2.5
PH296-03	PH296-03B	1.4
PH299-03	PH299-03B	2.0

3. Names and functions of driver part

The following is a description of names and functions of the driver front panel. Setting and switching of the driver's functions for operating the motor can all be performed from the internal function switches.

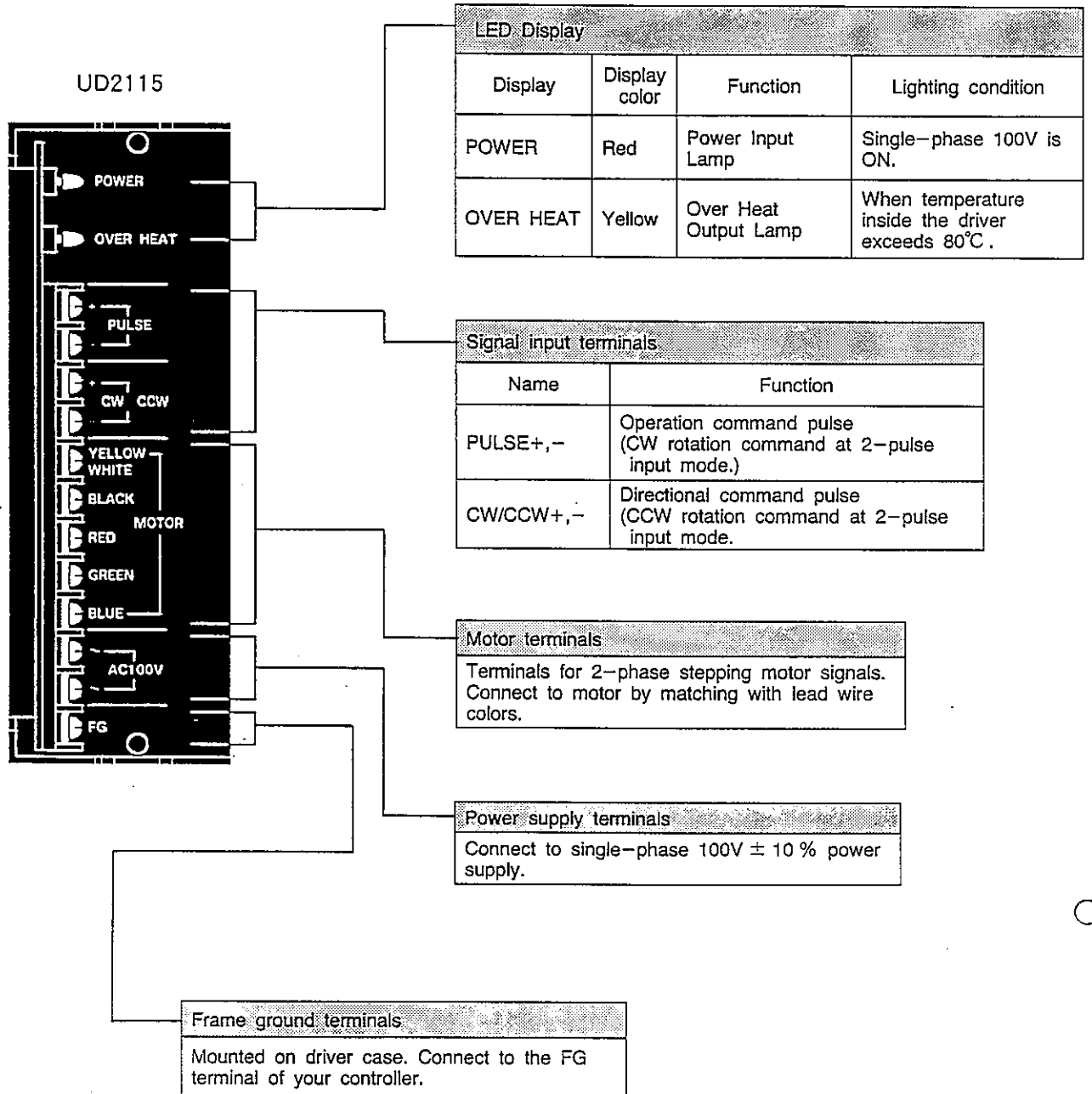

The following is a description of names and functions of internal switches inside of the driver. Remove the driver cover as shown below.

① Unscrew four screws on the driver case.

② Remove the driver cover.

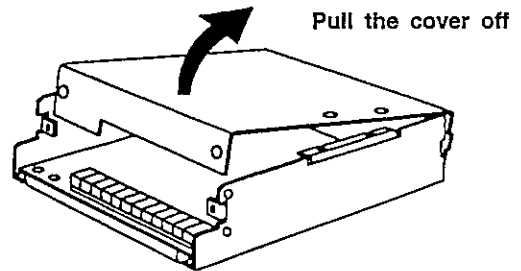
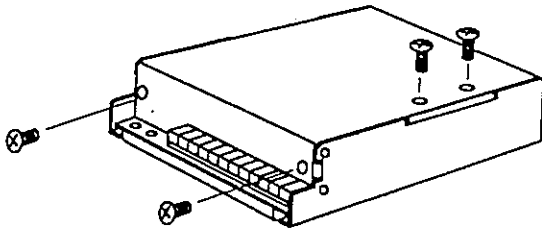

Inside of UD2115

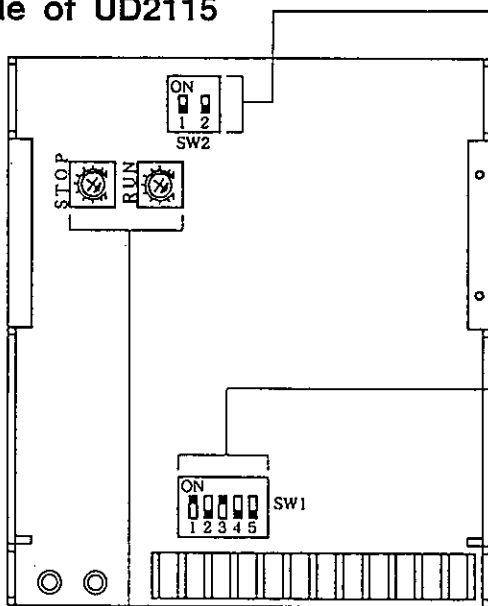

Function setting switch 2		
Name	Function	Function setting
No. 1 (Automatic Current Cutback)	When switch is OFF: The motor output current is automatically lowered after pulses cease.	OFF
No. 2 (Automatic Output Current Off)	When switch is OFF: Current output to the motor is automatically stopped when temperature inside the driver exceed 80° C.	OFF

Function setting switch 1		
Name	Function	Function setting
No. 1,2,3,4 (Pulse Input Mode)	When No. 1,3 OFF and No. 2,4 ON: 1-pulse input mode When No. 1,3 ON and No. 2,4 OFF: 2-pulse input mode	No. 1,3:OFF (1-pulse input mode) No. 2,4:ON
No. 5 (Step Angle)	ON: 0.9°/step OFF: 1.8°/step	OFF 1.8°/step (Full step)

Output current setting potentiometer		
Name	Function	Function setting
RUN	Potentiometer for adjusting motor operating current	Minimum
STOP	Potentiometer for adjusting current at motor standstill	Minimum

4. Connection

1 Connecting Diagram

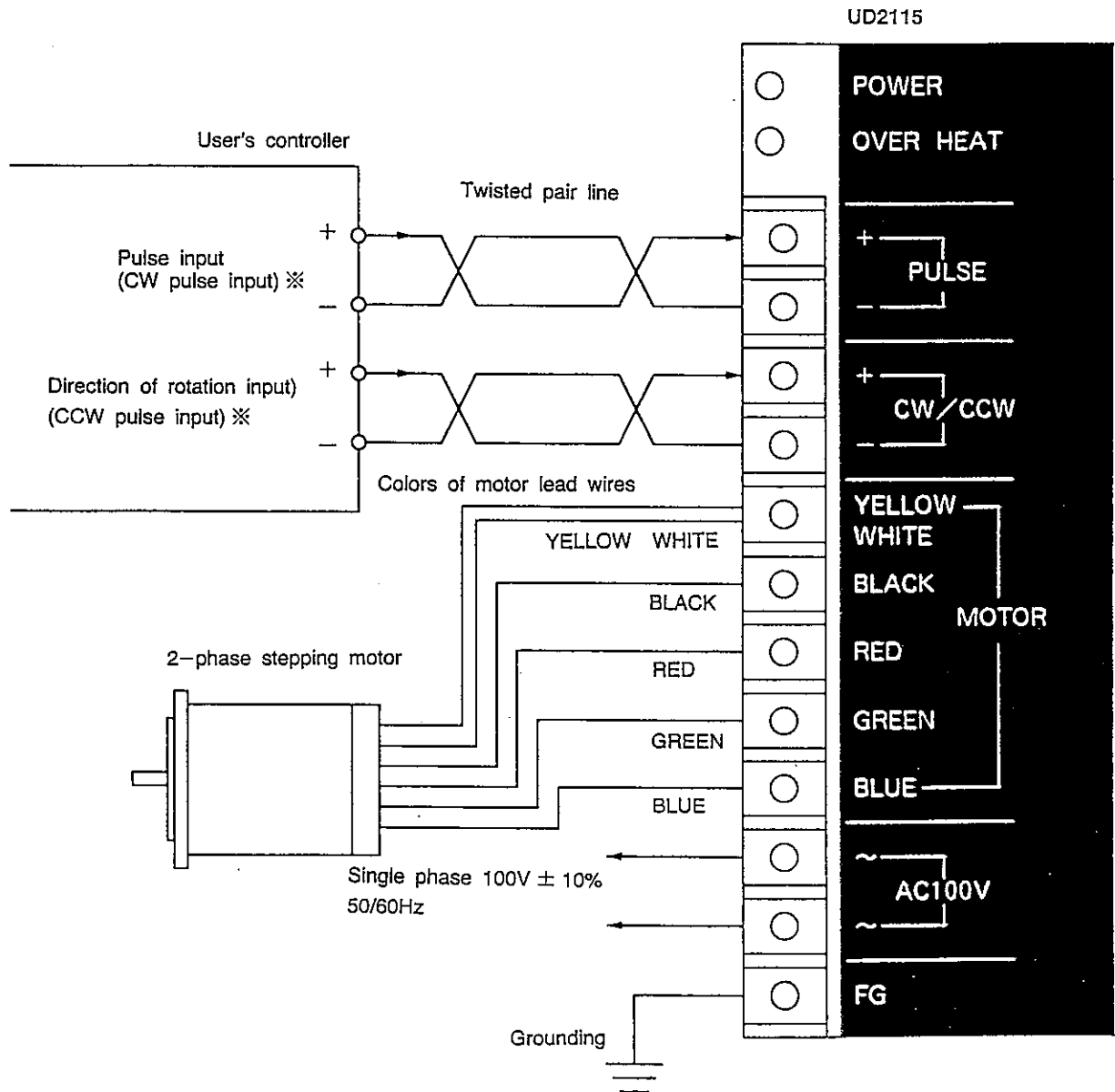

Cautions

- Use twisted-pair wire (0.2mm^2) of 1m or less in length for the signal lines.
- Use wire of 0.5mm^2 or thicker for motor lines (when extended) and power supply lines and use 0.75mm^2 or thicker for the wire for the ground line.
- Use spot grounding for the grounding of the driver and external controller.
- Signal lines should be kept away at least 30cm from power lines (power supply lines and motor lines). Do not bind the signal line and power line together.

2 Input/Output Signals

(1) CW/CCW (Pulse Input)

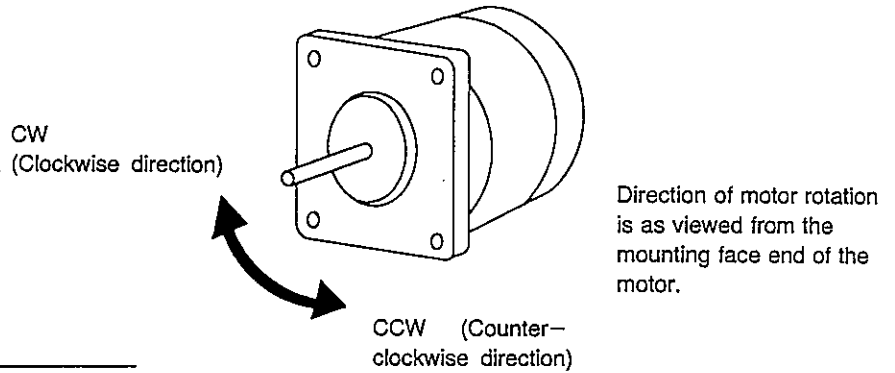

Internal Circuit And Pulse Wave

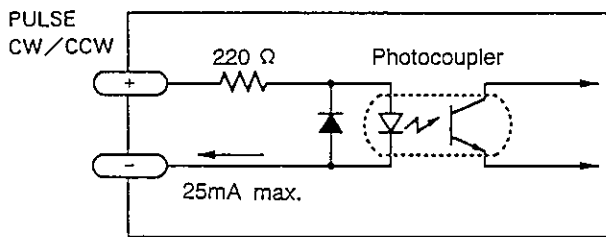

Note: 1. When using 1-pulse input mode, the direction of rotation should be changed only when pulses are stopped (at H level).
2. When using 2-pulse input mode, do not input CW and CCW pulses at the same time.

• 1-pulse input mode

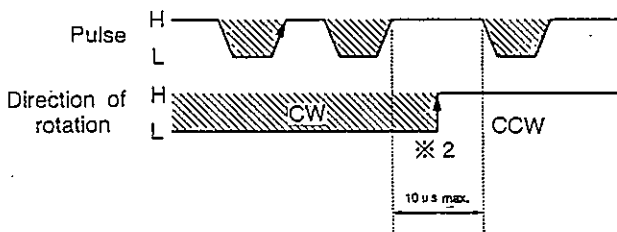

• 2-pulse input mode

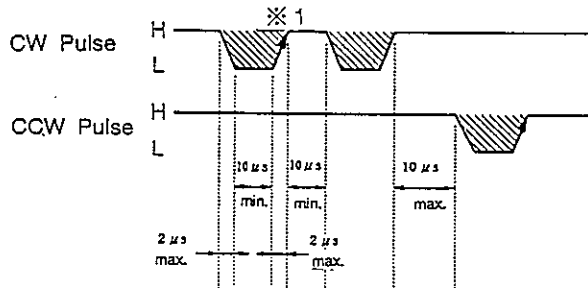

※ 1 : The photocoupler diode lights in shaded part. The motor moves at pulse rising edge (See arrows).

※ 2 : Motor rotates in CW direction at L level, CCW direction at H level.

- 1) Pulse voltages are 4 ~ 6V for H level and 0 ~ 0.5V for L level.
- 2) The input pulse should have a pulse width of at least 10 μs, rise and fall times of at most 2 μs and a maximum pulse duty of 50 % .
- 3) 10 μs minimum, an interval for changing the direction of rotation, is a nominal value. Time varies with motors and moment of load inertia.

Connecting Diagram

TTL-Negative Logic Drive

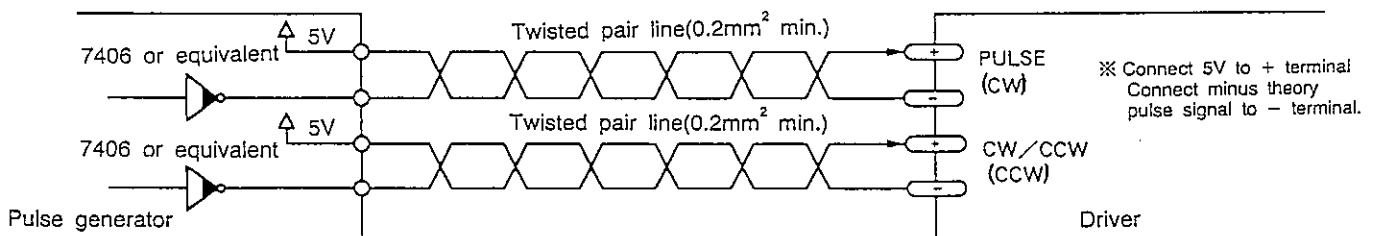

(2) MOTOR (connecting for 2 phase stepping motor)

- Connect the motor lead wires to the driver terminals by matching the colors of each.

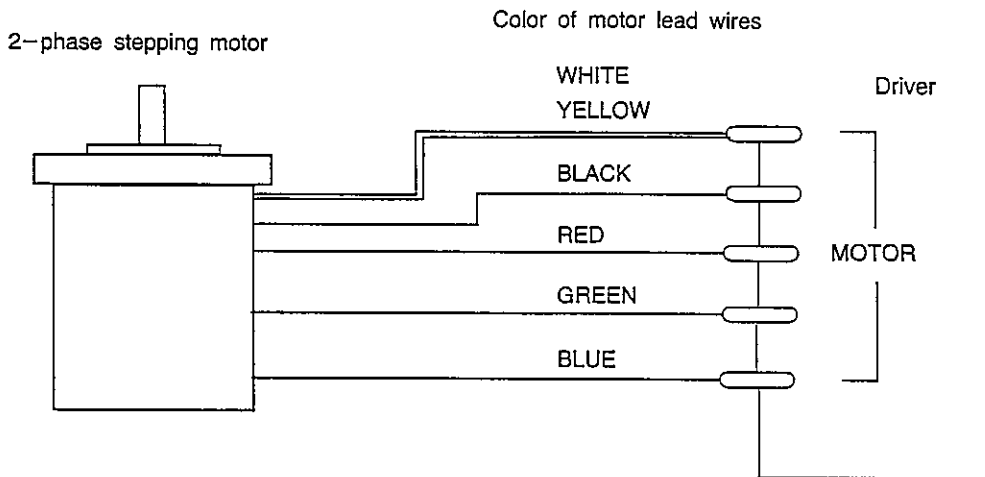

Note: Use wire of 0.5mm^2 or thicker for motor lines. 6-core cabtyre cord is recommended.

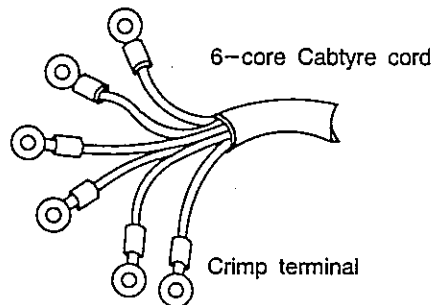

(3) AC100V (AC100V Input)

- Connect to the power supply of $\text{AC}100\text{V} \pm 10\%$, 50/60Hz.
- Using a stranded wire for the input line is an effective way to suppress noise. (Use wire of at least 0.5mm^2 .)

(4) Frame Ground (FG) Terminal

- Ground the driver's FG terminal to the FG terminal of the external pulse generator (or controller) in order to prevent malfunctions due to external noise.

■ Wiring Diagram

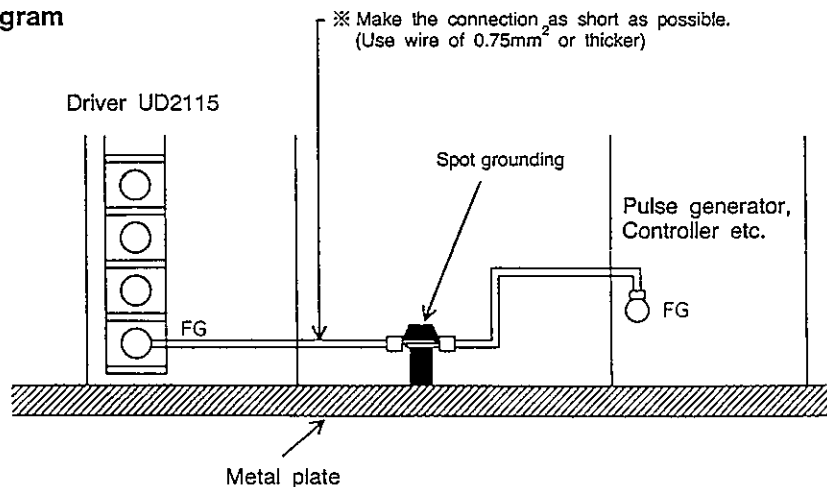

5. Operation

1 Customizing the driver

(1) Switching And Setting Function

Factory settings of the driver can be modified using the following function switches which are located inside the driver.

■ Pulse Input Mode

Internal Functionl Switch (SW1)

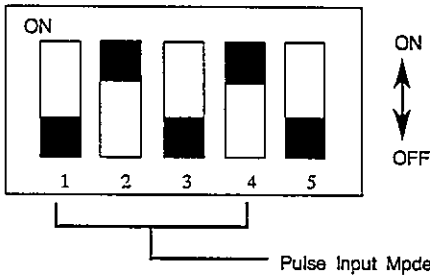

• Pulse Input Mode Setting Switch [No. 1,2,3,4]

When No. 1,3 of pulse input mode swichs are flipped to OFF and No. 2,4 are flipped to ON, the driver is set for 1-pulse input mode, in which a pulse signal and a direction of rotation signal are used to control the motor.

When No. 1,3 are flipped to ON and No.2,4 are flipped to OFF, the driver is set for 2-pulse input mode, in which two types of pulse signals (one each for CW and CCW) are used to control the motor.

■ Step Angle

Internal Functionl Switch (SW1)

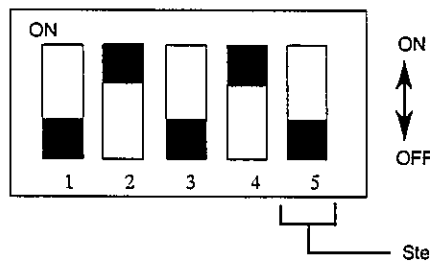

• Step Angle Setting Switch [No. 5]

When step angle switch is flipped to OFF, the driver is set for 1.8° /step (full step, 200 pulses per revolution).

When the switch is flipped to ON, the driver is set for 0.9° /step (half step, 400 pulses per revolution).

■ Automatic Current Cutback at Motor Standstill

Internal Functionl Switch (SW2)

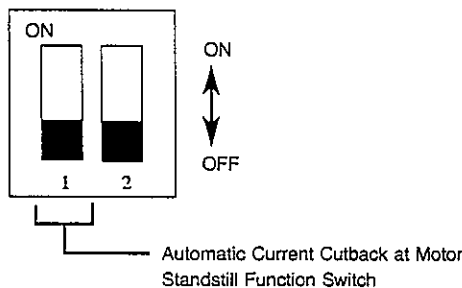

• When Automatic Current Catback switch [No. 1] is flipped to OFF, the *Automatic Current Cutback at Motor Standstill* function is set. Approximately 0.2 seconds after pulses cease, the motor output current is automatically lowered to suppress heat generation in the motor and driver.(The rate of current cutback is shown in the paragraph of " Setting the current at motor standstill " on page 9.)

• Generally, the switch should be at ON side. (If it is flipped to A.C.⊙, the *Automatic Current Cutback at Motor Standstill* function is cancelled.)

■ Automatic Output Current Off

Internal Functionl Switch (SW2)

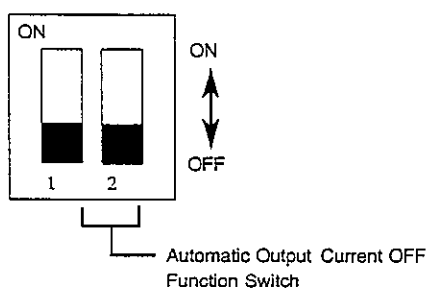

• When Automatic Output Current Off switch [No. 2] is flipped to OFF, the *Automatic Output Current Off* function is set. When the overheat signal is output (when temperature of heat radiation plate inside the driver exceeds 80 °C) current output to the motor is automatically stopped and the motor comes to a natural stop.

• In situation where stopping of the motor due to overheat signal could pose problems, *Automatic Output Current Off* can be overridden by setting the switch to ON. However, as a rule, whenever the overheat signal is output, the motor should be stopped as soon as possible.

Caution: • Switch should be changed only driver's power is off.



(2) Adjusting Motor Output Current

This driver was shipped with the output current to the motor set to a low level. When resetting this current, be sure to follow the procedures below.

■ Setting The Motor Operating Current

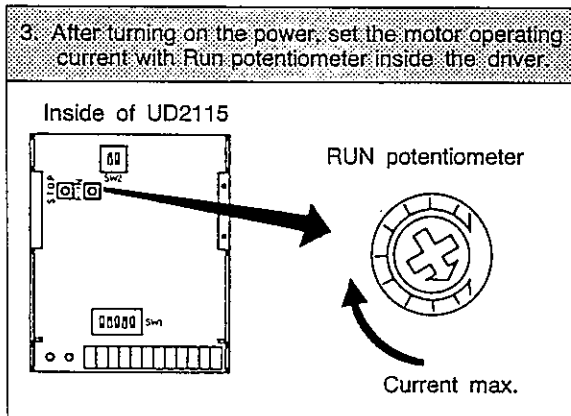
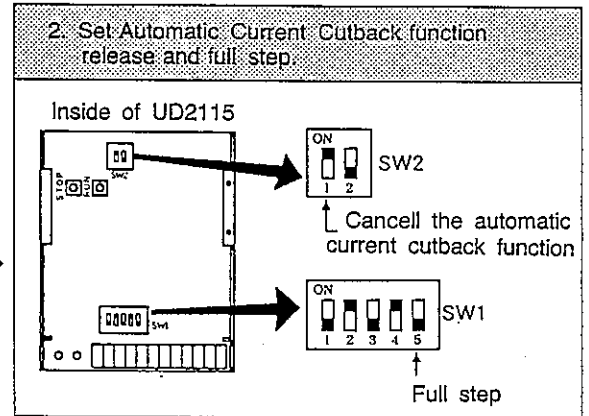
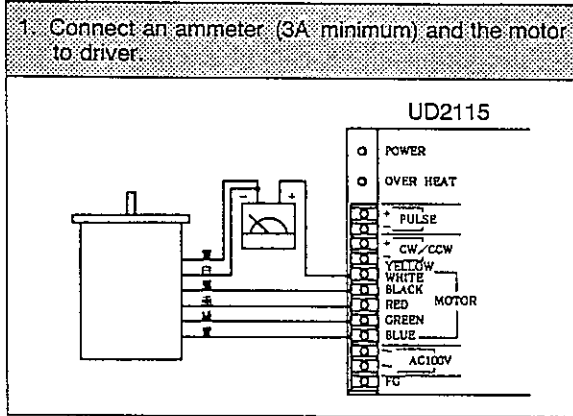

After adjusting the motor operating current, adjust the current during the motor is stopped.

※ 1 Following graph shows operating current value (A/total) against the RUN potentiometer scale.

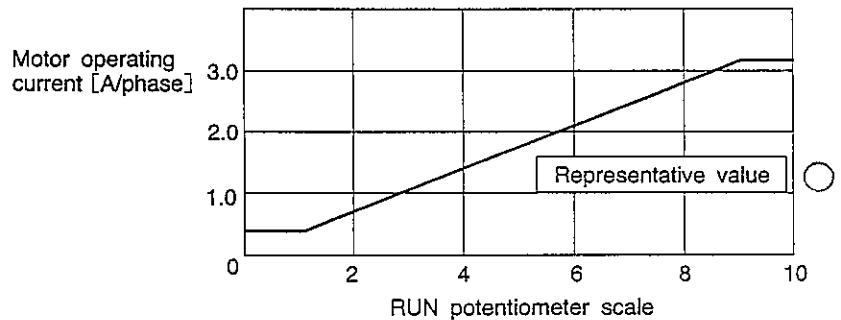
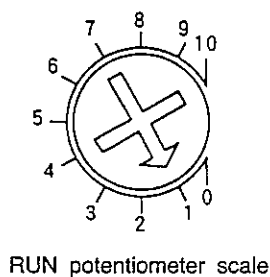

• Operating Current of Applicable Motor

Applicable Stepping Motors	Operating Current (A/total)	Position Setting of RUN Potentiometer
PH264-01(B)	2.2	⑥
PH265-01(B)	1.7	The center of ④ and ⑤
PH266-01(B)	2.4	The center of ⑥ and ⑦
PH268-01(B)	3.0	The center of ⑧ and ⑨
PH268-21(B)	3.0	The center of ⑧ and ⑨
PH296-02(B)	2.5	⑦
PH296-03(B)	1.4	④
PH299-03(B)	2.0	The center of ⑤ and ⑥

Caution:

Do not matching this driver and PX type 2 -phase stepping motor because of high heat generation.

Note: Re-adjustment is required in case of following conditions.

- To lower the operating current in order to suppress temperature rise in the motor/driver.
- To lower the operating current in order to allow a margin for motor torque or to suppress vibration.

■ Setting The Current At Motor Standstill

Heat generation of motor and driver become high when keep supplying the operating current to the motor during the motor stops. Approximately 0.2 seconds after pulse cease, the motor output current is lowered to suppress heat generation.

Turn off the power after setting the motor operating current.

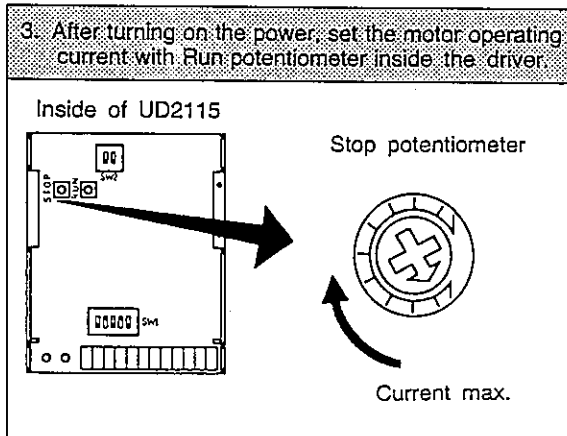
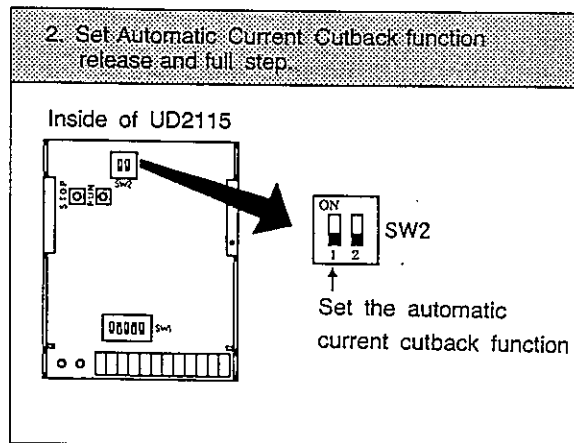

Current adjustment is completed.

Remove the ammeter, set the each function.

※ 2 Following graph shows the current at motor standstill against the STOP potentiometer scale.

$$\text{Current at motor standstill} = \text{Motor operating current} \times \frac{\text{Standstill current to be set}}{100}$$

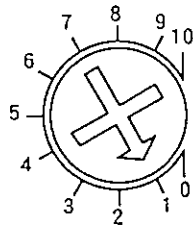

Stop potentiometer scale

Rate of current cutback [%]

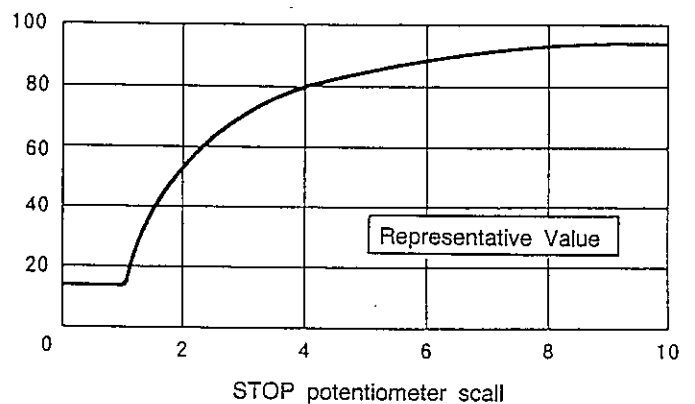

Caution: When holding torque is necessary during motor standstill, release the *Automatic Current Cutback at Motor Standstill* function. In such case, pay attention to heat generation of motor and driver.

2 LED indication when turning on the power

Before turning on the power, confirm that there are no mis-wiring in the signal lines, motor and power lines. Following LED lamp illuminates when the power is on. (Do not input the pulse signal.)

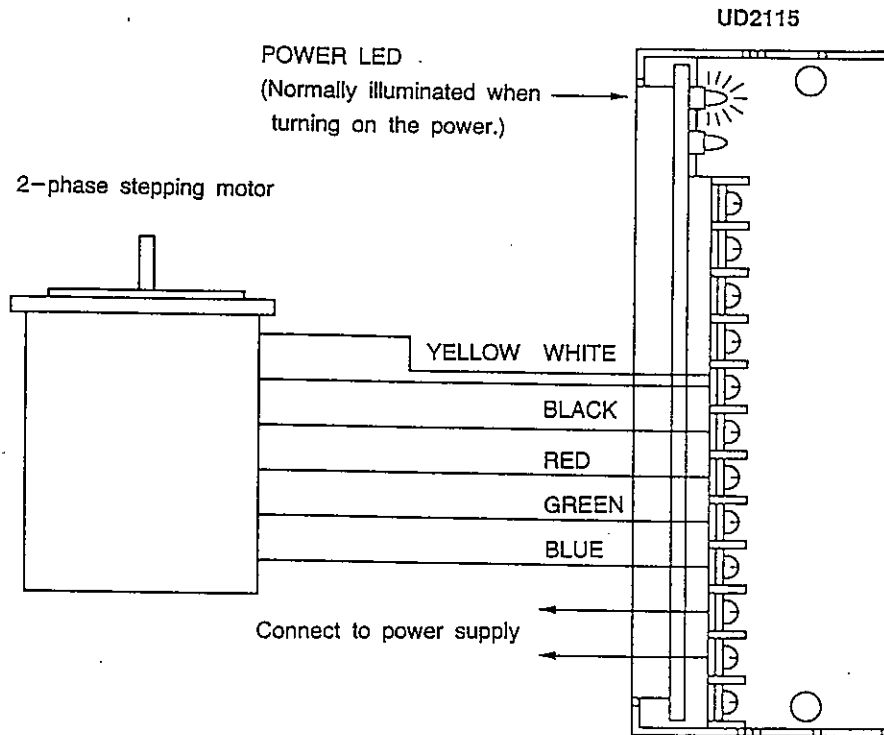

Caution: Turning the power back on

After the power has been turned off, wait 30 seconds before turning it back on again.

If the power is turned on again immediately after it has been turned off, the timing lamp will not be illuminated and the motor excitation sequence will not be reset to step "0".

3 Confirmation for Motor Operation (At 1-pulse input mode)

If the procedures given in sections 1 and 2 above have been completed properly, send pulses to the driver. (The motor should have no load.)

Send pulses (the pulse ratio is approximately 400 to 600pps) to the input pulse terminal. Check to see that the motor shaft is rotating in a CCW (counterclockwise) direction when viewing from the surface on which the motor is mounted. Then change the direction of rotation, and check in the same manner.

6. Installation

1 Installing the driver

When installing the driver, refer the following figures. Two ways of installation can be possible.

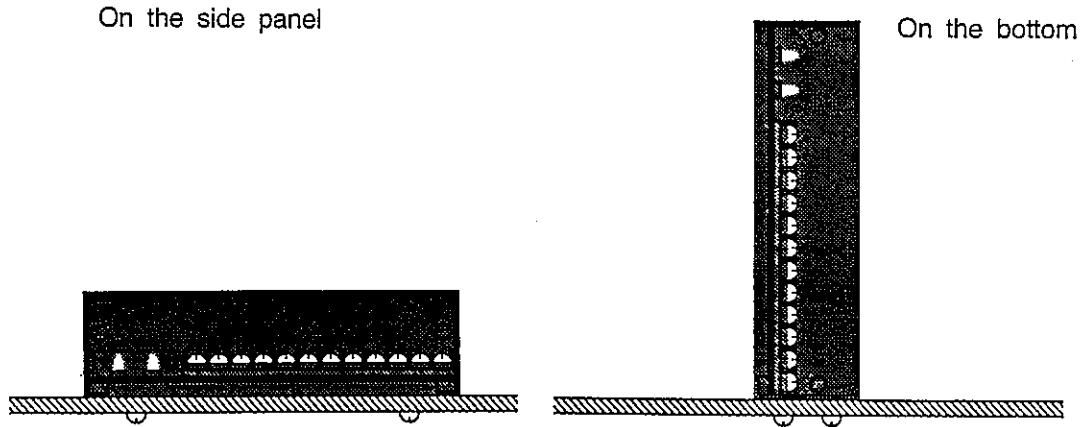

Mounting pitch is as the following figures.

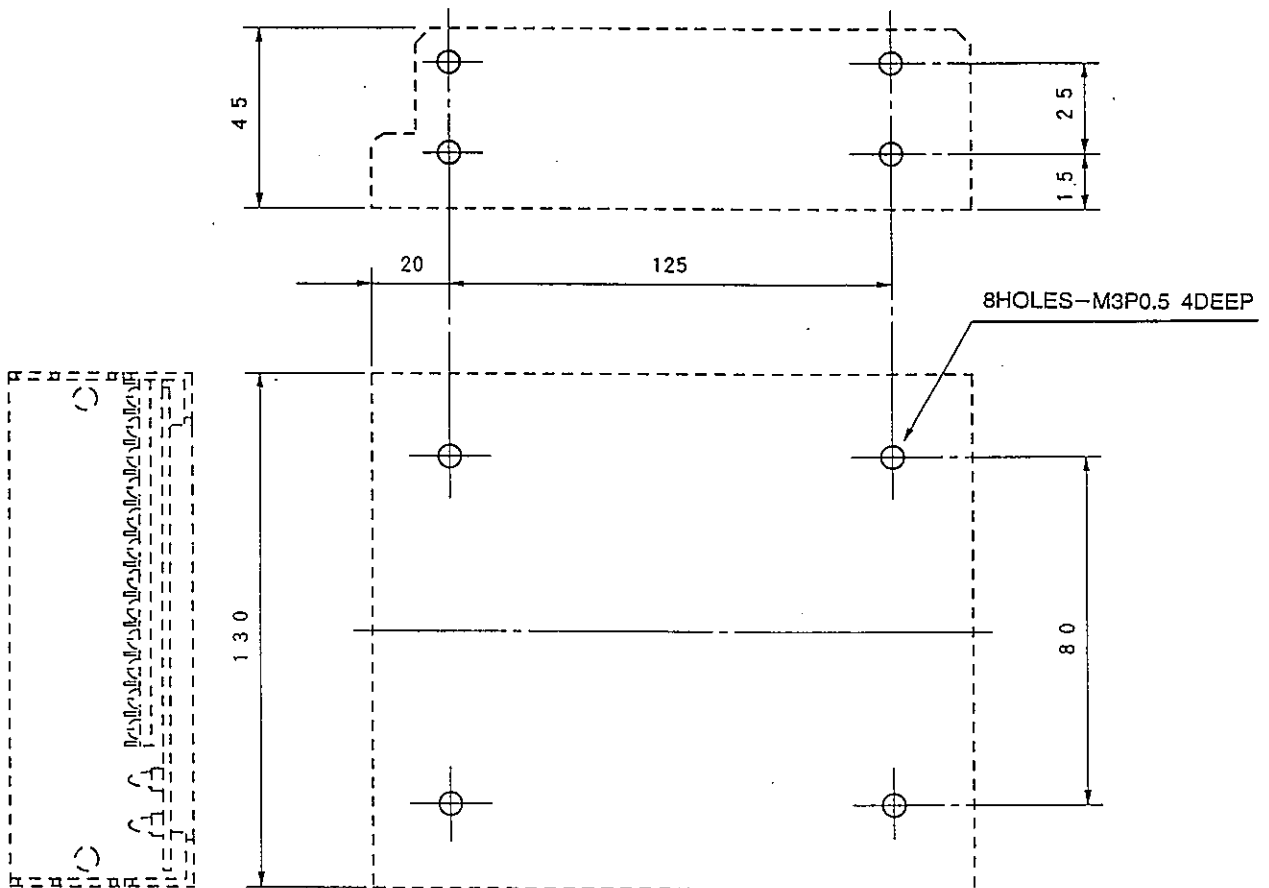

Note: This driver have M3 tapping holes on the side and bottom panel.

Do not allow the screws to extend more than 4mm into the driver when using this tapping hole.

2 Precautions for installing

- (1) When installing more than two drivers, any rise in the temperature of the driver will rise the ambient temperature. Drivers should be installed so that a space of at least 20mm is maintained between drivers.
- (2) Forced cooling by a fan is recommended when the ambient temperature is high.

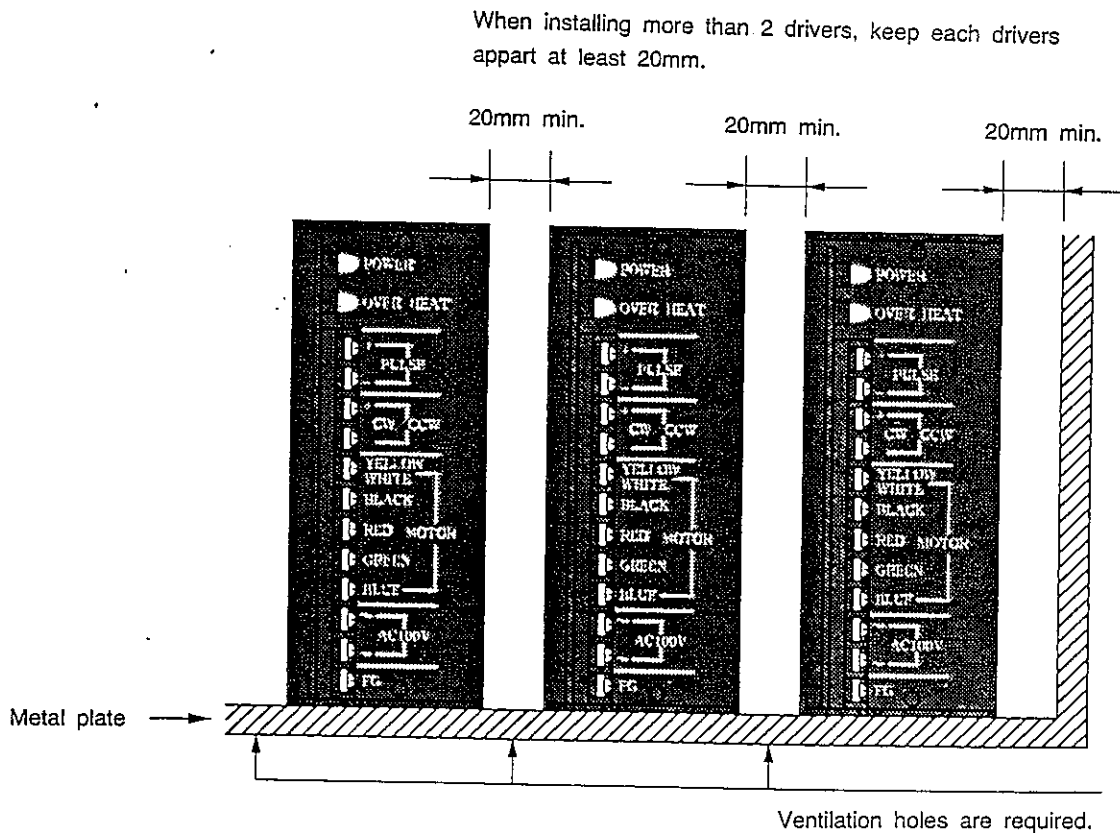

- Do not use the components in a place where dust, oil mist, pieces of conductive material and corrosive gas are existent.
- Avoid place where vibrations/shocks are heavy.
- Drivers should be installed so that a space of at least 25mm is maintained between drivers.
- In the case that the drivers are located close to a large noise source (such as a high tension wire, a pressure machine and electric machine etc.), the induction noise tends to be mixed with the input circuit and power supply circuit etc. and that become the cause of malfunctions. In this case, take steps to prevent noise interference, either by inserting noise filters or connecting the driver to a separate circuit.
- Avoid place where the ambient temperature exceeds 0°C ~ 40°C .
- Take care that pieces of conductive material (filings, pins, etc.) not to enter the driver.

7. Dimensions

■ Driver: UD2115

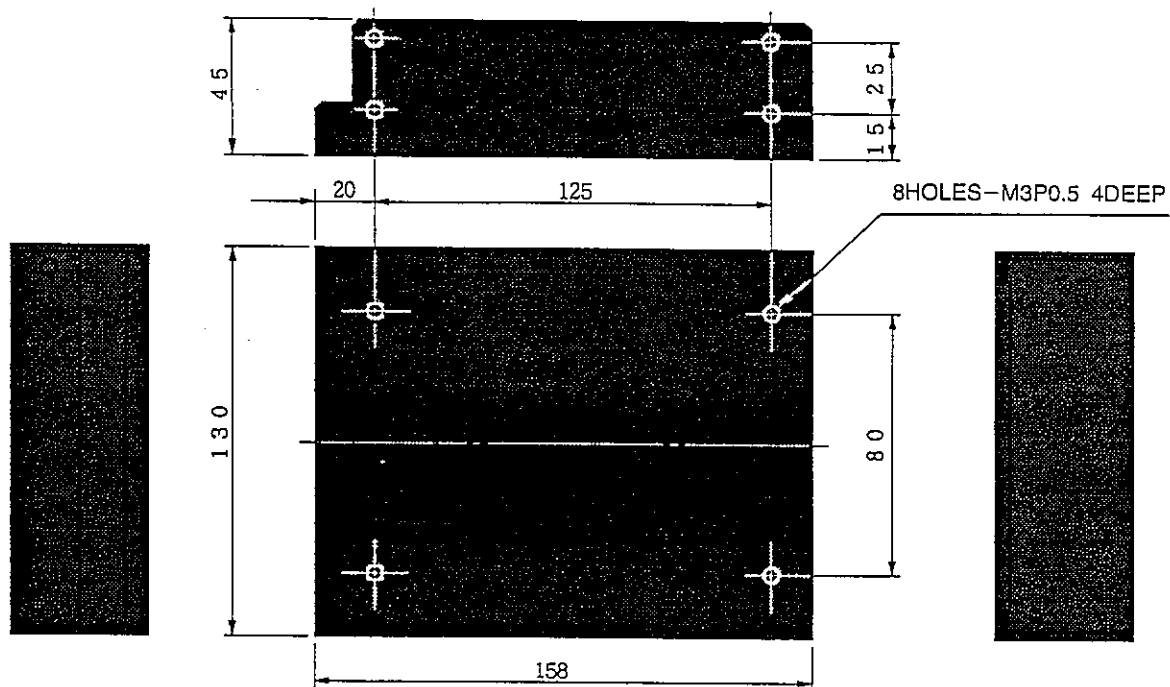

8. Specifications

Power Supply	Single-phase 100V \pm 10% 50/60Hz 150VAmx.	
Excitation Mode	Unipolar constant current drive	
Motor Current	Total 1A \sim 3A	
Step Angle	Full step 1.8°/step (2 phase excitation) Half step 0.9°/step (1-2 phase excitation) (Step angle can be switched by internal function switch.)	
Input Signal	Input Signal Circuit	Photocoupler input, Input impedance: 220 Ω H: +4 \sim +5V, L: 0 \sim 0.5V Input current 25mA maximum
	Pulse Input (PULSE)	Pulse width: 5 μ sec min. Pulse rise/Pulse fall time: 1 μ sec max. (CW pulse input when 2-pulse input mode) Motor moves at pulse falling edge.
	Direction of Rotation Input (CW/CCW)	L: CW, H: CCW (CCW pulse input when 2-pulse input mode)
Automatic Current Cutback at Motor Standstill Functions	Approximately 0.2 seconds after pulse cease, the motor output current is automatically lowered by 30% \sim 80% of the setting current. (This function can be cancelled by internal function switch.)	
Automatic Output Current OFF Function	When temperature of inside the driver exceed 80°C current output to the motor is automatically stopped and overheat LED on the front panel light.	
Insulation Resistance	100M Ω or more when 500V DC is applied between the power supply terminal and the case.	
Insulation Strength	Sufficient to withstand 1kV at 50Hz applied between the power supply terminal and the case for one minute.	
Ambient Temperature	0°C \sim +40°C	
Dimensions	45(W) \times 130(H) \times 158(D) mm	
Mass	Approximately 0.6kg	

9. Timing Chart (At 2 – pulse input mode)

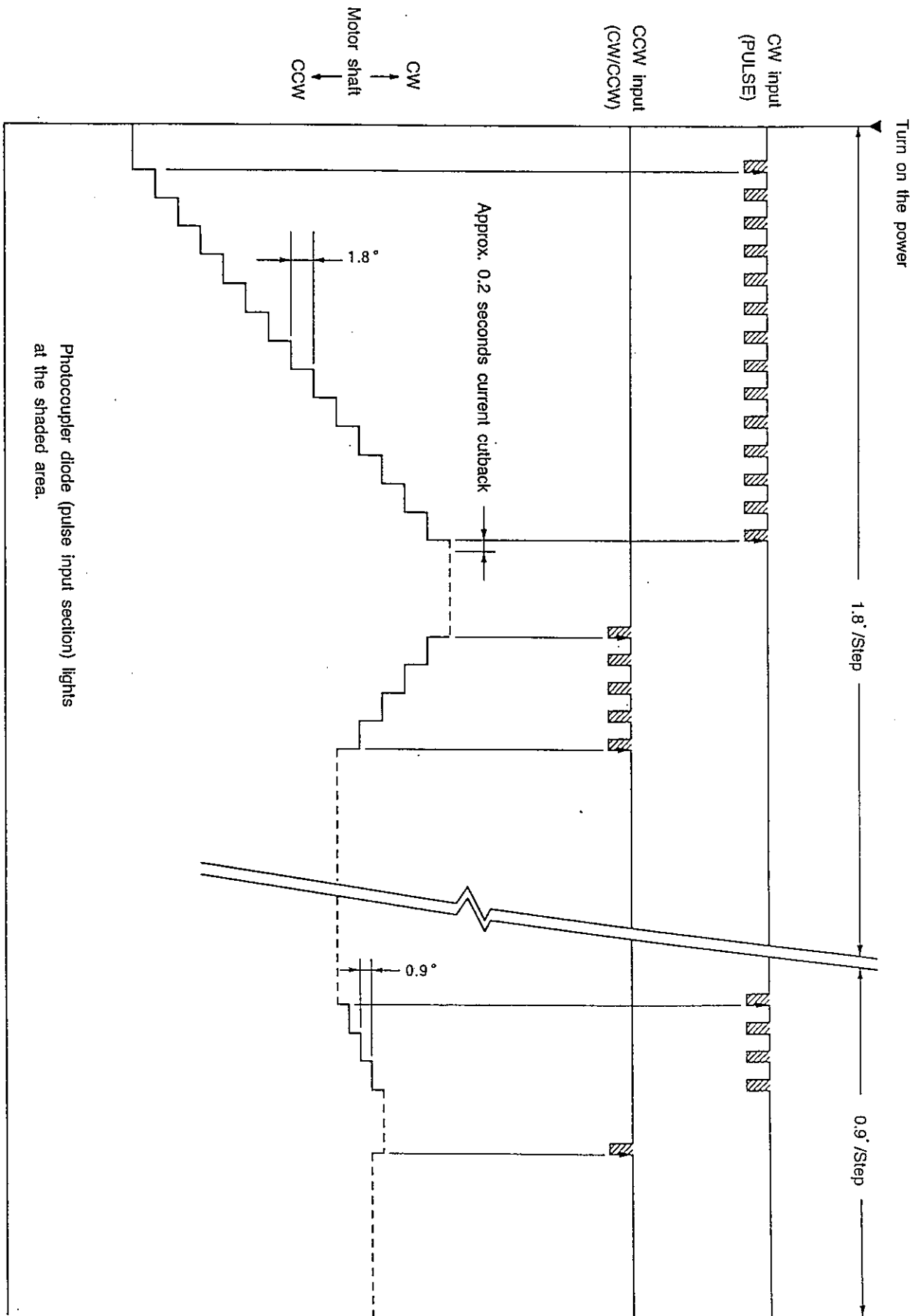

10. Trouble Shooting

Check the driver once again before requesting servicing.
 When the driver is not functioning properly, perform the following checks and take the following measures.
 If the driver continues malfunction, please call your nearest Oriental Motor.

Problem	Check Points
1 Power LED does not light.	Check that the power is connected. Check that the internal fuse is broken. (When the internal fuse is broken, the driver may be broken, too. Repair must be required.)
2 The motor is not excited, (The motor has no holding torque.) The motor shaft rotates easily by hand.	·Is the POWER LED on? ·Is the motor connected properly? ·Have the H.OFF signal been input? ·Is the O.H. LED on? ·Have the driver's STOP potentiometer been turned too far down? ·Is the motor lead wire broken? (When lead wire is extended, check that the connections are proper and the crimp terminal is connected securely.)
3 The motor does not rotate even after input of the pulse signal. The motor rotates in the opposite direction.	·Is the motor connected properly? ·Are CW and CCW pulse signals input conversely and are they input at the same time? ·Is the pulse input mode proper? ·Have the H.OFF signal been input? ·Is the voltage level of pulse signal proper? ·Have pulse signals been input? (Does TIMING LED light?)
4 The motor is not functioning properly. The motor loses synchronism during operation.	·Are the motor and the load properly centered? Is the load too large? ·Is the voltage level of pulse signal proper? ·Have H.OFF signal been input during operation? ·Is the acceleration/deceleration time too short?

Problem	Cause	Measures
5 In cases where there is not trouble with the driver or motor, but motor positioning errors still occur, the problem may be caused by the followings:	① Mismatching of the motor and the load. (shortage of torque or misalignment)	Check the motor movement with the load disengaged.
	② Misadjustment of controller. (pulse-generator) ·Starting pulse rate is too high. ·Acceleration/deceleration time is too short.	Slowed the motor speed or lengthen the acceleration/deceleration time.
	③ Misworking of the driver from external noise.	Check the motor's movement without operating any other apparatus which could be potential sources of noise.

Characteristics, specifications and dimensions are subject to change without notice.
Please contact your nearest ORIENTAL MOTOR office for further information.

ORIENTAL MOTOR CO., LTD.

16-17, Ueno 6-Chome, Taito-ku,
Tokyo 110, Japan
Tel:(03)3835-0684
Fax:(03)3835-1890