

Jumpers

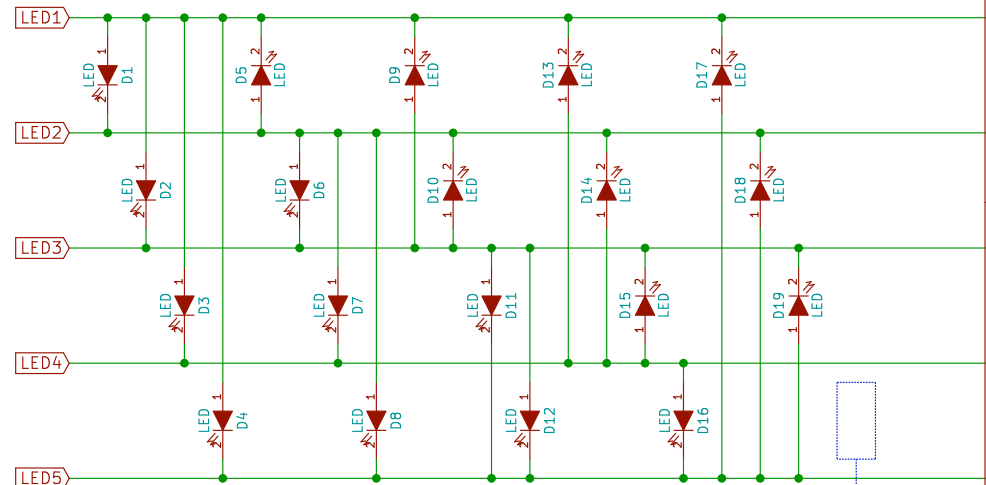
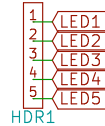
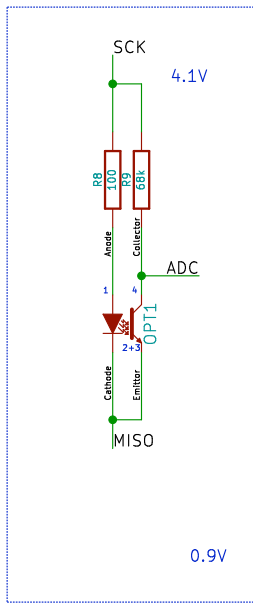
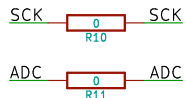

5V input 20mA 3.2V forward voltage
 2x 450hm resistor
 1.8V drop across both resistors
 this drop will be the same when there is 20mA going though the IR led
 So as long as long as the IR led uses the same current, the voltage
 will be "clamped" to the 3.2V forward voltage of the white leds

Sheet: /
 File: shoes-led.sch

Title:

Size: A4 Date:
 KiCad E.D.A. kicad 4.0.2-stable

Rev:
 Id: 1/1