



E22-400M22S User Manual

SX1268 433/470MHz SMD Wireless Module



目录

1. OVERVIEW	2
1.1 INTRODUCTION	2
1.2 FEATURES	2
1.3 APPLICATION.....	2
2. SPECIFICATION AND PARAMETER	3
2.1 LIMIT PARAMETER.....	3
2.2 OPERATING PARAMETER	3
3. SIZE AND PIN DEFINITION	4
4. BASIC OPERATION	5
4.1 HARDWARE DESIGN.....	5
4.2 SOFTWARE PROGRAMMING	6
5. BASIC APPLICATION	7
5.1 BASIC CIRCUIT	7
6. FAQ	7
6.1 COMMUNICATION RANGE IS TOO SHORT	7
6.2 MODULE IS EASY TO DAMAGE	8
6.3 HIGH BIT ERROR RATE	8
7. WELDING OPERATION GUIDANCE	8
7.1 REFLOW SOLDERING TEMPERATURE.....	8
7.2 REFLOW SOLDERING CURVE.....	9
8. RELATED MODEL	9
9. ANTENNA TYPE	10
9.1 ANTENNA RECOMMENDATION.....	10
REVISION HISTORY	11
ABOUT US	11

1. Overview

1.1 Introduction

The E22-400M22S is based on the SX1268, a new generation of LoRa™ RF chip manufactured by Semtech, USA. It is an ultra-small and self-developed 433MHz, 470MHz SMD LoRa™ wireless module.

Because it adopted the original SX1268 as main core, so the anti-interference performance and communication distance have been further improved compared to the previous generation LoRa™ transceiver. Due to its new LoRa™ modulation technology, the anti-interference performance and communication distance are far superior to the current FSK and GFSK modulation products. This module is mainly for smart home, wireless meter reading, scientific and medical research, and long distance wireless communication equipment. The RF performance and components selection are all in accordance with industrial-grade standards and this products obtained FCC, CE and RoHS certification already and so users do not need to worry about the performance. Adopted industrial grade high precision 32MHz crystal, the product can cover an ultra-wide frequency range of 410~493MHz and is backward compatible with SX1278 and SX1276.

Since the module is a RF transceiver module only, users need to use the MCU driver or use a dedicated SPI debug tool.



1.2 Features

- Communication distance tested is up to 7km ;
- Maximum transmission power of 160mW, software multi-level adjustable ;
- Support the global license-free ISM 433MHz/470MHz band ;
- Support air data rate of 0.018-62.5kbps in the LoRa™ mode ;
- Support 300kpbs in the FSK mode;
- Compared with the transceiver of SX1278/SX1276;
- With large capacity, FIFO supports 256Byte data cache.;
- New SF5 spreading factor to support dense networks;
- Support 2.5V~3.7V power supply, more than 3.3V power supply can guarantee the best performance;
- Industrial grade standard design, support -40 ~ 85 °C for working over a long time ;
- IPEX and stamp hole optional, good for secondary development and integration.

1.3 Application

- Home security alarm and remote keyless entry ;
- Smart home and industrial sensors ;
- Wireless alarm security system ;
- Building automation solutions ;
- Wireless industrial-grade remote control ;

- Health care products ;
- Advanced Meter Reading Architecture(AMI) ;
- Automotive industry applications.

2. Specification and parameter

2.1 Limit parameter

Main parameter	Performance		Remark
	Min.	Max.	
Power supply (V)	0	3.7	Voltage over 3.7V will cause permanent damage to module
Blocking power (dBm)	-	10	Chances of burn is slim when modules are used in short distance
Operating temperature (°C)	-40	85	-

2.2 Operating parameter

Main parameter		Performance			Remark
		Min.	Typ.	Max.	
Operating voltage (V)		1.8	3.3	3.7	≥3.7 V ensures output power
Communication level (V)		-	3.3	-	For 5V TTL, it may be at risk of burning down
Operating temperature (°C)		-40	-	85	Industrial design
Operating frequency (MHz)		410	433/470/490	493	Support ISM band
Power consumption	TX current (mA)	-	100	-	Instant power consumption
	RX current (mA)	-	6.5	-	-
	Sleep current (μA)	-	180	-	Software is shut down
Max Tx power (dBm)		21.4	21.5	22.3	-
Receiving sensitivity (dBm)		-144	-146	-147	Air data rate is 0.3kbps
Air data rate (bps)		0.6k	-	300k	Controlled via user's programming
		0.018k	-	62.5k	Controlled via user's programming

Main parameter	Description	Remark
Distance for reference	7000m	Test condition : clear and open area, antenna gain: 5dBi, antenna height: 2.5m, air data rate: 0.3kbps
FIFO	256Byte	Maximum length of single transmission
Crystal frequency	32MHz	-
Modulation	LoRa	-
Package	SMD	-
Connector	1.27mm	Stamp hole

Communication interface	SPI	0-10Mbps
Size	20* 14*2.8 mm	-
Antenna	IPEX/stamp hole	50 ohm impedance

3. Size and pin definition

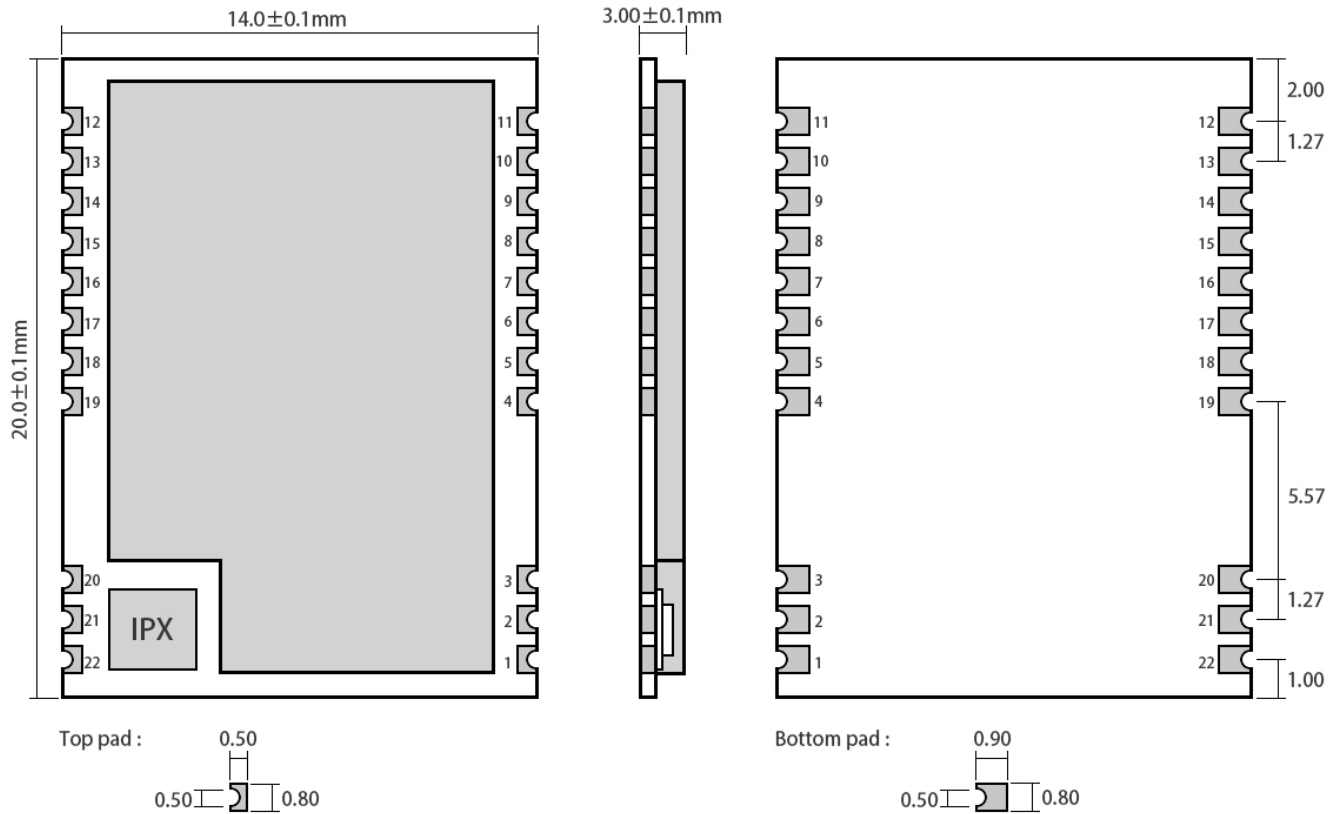

Pad quantity : 22
Unit: mm

No.	Name	Direction	Function
1	GND	-	Ground
2	GND	-	Ground
3	GND	-	Ground
4	GND	-	Ground
5	GND	-	Ground
6	RXEN	Input	RF switch receiving control pin, connected to external microcontroller IO, valid in high level

7	TXEN	Input	RF switch transmitting control pin, connected to external microcontroller IO or DIO2, valid in high level
8	DIO2	Input/Output	Configurable universal IO port (see SX1262 manual for details)
9	VCC	Output	Power supply, 1.8V~3.7V (it is recommended to add external ceramic filter capacitor)
10	GND		Ground
11	GND		Ground
12	GND		Ground
13	DIO1	Input/Output	Configurable universal IO port (see SX1262 manual for details)
14	BUSY	Output	For status indication (see SX1262 manual for details)
15	NRST	Input	Chip reset trigger input pin, valid in low level
16	MISO	Output	SPI data output pin
17	MOSI	Input	SPI data input pin
18	SCK	Input	SPI clock input pin
19	NSS	Input	Module chip select pin for starting an SPI communication
20	GND		Ground
21	ANT		Antenna interface, stamp hole (50 ohm characteristic impedance)
22	GND		Ground

4. Basic Operation

4.1 Hardware Design

- It is recommended to use DC stabilized power supply to supply power to the module. The power supply ripple coefficient is as small as possible, and the module needs to be reliably grounded.
- Please pay attention to the correct connection of the positive and negative poles of the power supply. If the reverse connection is connected, the module may be permanently damaged.
- Please check the power supply to ensure that between the recommended supply voltage, if exceeding the maximum, the module will be permanently damaged.
- Please check the stability of the power supply, the voltage can not be significantly frequent.
- When designing the power supply circuit for the module, it is often recommended to reserve more than 30% of the margin, and the whole machine is beneficial for long-term stable operation.
- The module should be as far away as possible from the power supply, transformers, high-frequency wiring and other parts with large electromagnetic interference.
- High-frequency digital traces, high-frequency analog traces, and power traces must be avoided under the module. If it is necessary to pass through the module, assume that the module is soldered to the Top Layer, and the copper is

spread on the Top Layer of the module contact part(All copper-covered and well grounded), and must be close to the digital part of the module and routed in the Bottom Layer.

- Assuming the module is soldered or placed in the Top Layer, it is also wrong to randomly route the Bottom Layer or other layers, which will affect the module's spurs and receiving sensitivity to varying degrees.
- Assume that there are traces with large electromagnetic interference around the module (high-frequency digital, high-frequency analog, power trace), which will greatly affect the performance of the module. It is recommended to stay away from the module according to the strength of the interference. If necessary, appropriate isolation and shielding can be done;
- If the communication line uses a 5V level, a 1k-5.1k resistor must be connected in series (not recommended, there is still a risk of damage).
- Try to stay away from some physical layers and also have a 2.4GHz TTL protocol, for example: USB3.0
- The antenna mounting structure has a great influence on the performance of the module. It is necessary to ensure that the antenna is exposed, preferably vertically upward. When the module is mounted inside the case, use a good antenna extension cable to extend the antenna to the outside of the case.
- The antenna must not be installed inside the metal case, which will greatly reduce the transmission distance.
- It is recommended to add a 200R protection resistor to the RXD/TXD of the external MCU.

4.2 Software Programming

- This module is SX1268/SX1262+PA+LNA. Its driving mode is exactly the same as SX1268/SX1262. Users can operate according to SX1268/SX1262 chip datasheet.
- DIO1 and DIO2 are general-purpose IO ports, which can be configured into multiple functions. DIO2 can be connected to TXEN and not connected to the MCU's IO port. It can be used to control the RF switch transmission. If not used, you can hang it. For details, see the SX1262 manual.
- DIO 3 is used to supply 32 MHz TCXO crystal oscillator.

5. Basic application

5.1 Basic circuit

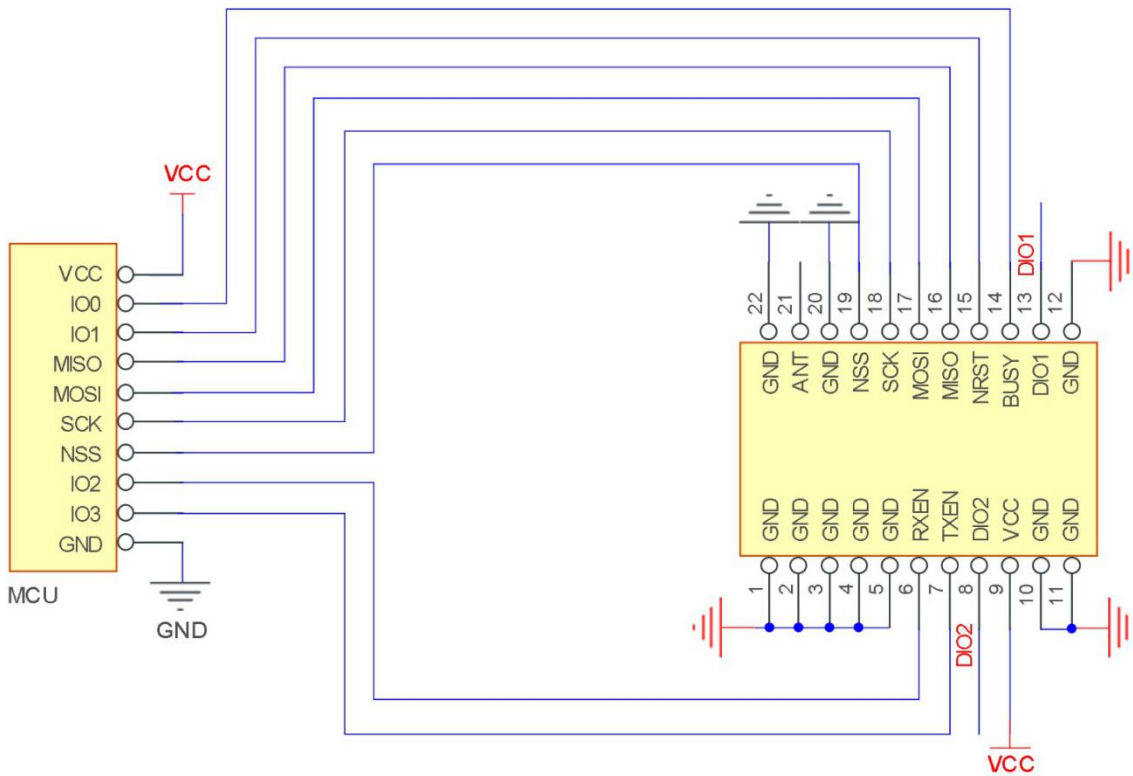

6. FAQ

6.1 Communication range is too short

- The communication distance will be affected when obstacle exists.
- Data lose rate will be affected by temperature, humidity and co-channel interference.
- The ground will absorb and reflect wireless radio wave, so the performance will be poor when testing near ground.
- Sea water has great ability in absorbing wireless radio wave, so performance will be poor when testing near the sea.
- The signal will be affected when the antenna is near metal object or put in a metal case.
- Power register was set incorrectly, air data rate is set as too high (the higher the air data rate, the shorter the distance).
- When the power supply at room temperature is lower than the recommended low voltage, the lower the voltage is, the lower the transmitting power is.
- Due to antenna quality or poor matching between antenna and module.

6.2 Module is easy to damage

- Please check the power supply and ensure it is within the recommended range. Voltage higher than the peak will lead to a permanent damage to the module.
- Please check the stability of power supply and ensure the voltage not to fluctuate too much.
- Please make sure anti-static measures are taken when installing and using, high frequency devices have electrostatic susceptibility.
- Please ensure the humidity is within limited range for some parts are sensitive to humidity.
- Please avoid using modules under too high or too low temperature.

6.3 High bit error rate

- There are co-channel signal interference nearby, keep away from interference sources or modify frequency, channel to avoid interference.
- The clock waveform on the SPI is not standard. Check whether there is interference on the SPI line. The SPI bus line should not be too long.
- Unsatisfactory power supply may also cause garbled characters, and ensure the reliability of the power supply.
- If the extension cable or feeder is of poor quality or too long, the bit error rate will be high.

7. Welding operation guidance

7.1 Reflow Soldering Temperature

Profile Feature	Curve feature	Sn-Pb Assembly	Pb-Free Assembly
Solder Paste	Solder paste	Sn63/Pb37	Sn96.5/Ag3/Cu0.5
Preheat Temperature min (T _{smin})	Minimum preheating temperature	100°C	150°C
Preheat temperature max (T _{smax})	Maximum preheating temperature	150°C	200°C
Preheat Time (T _{smin} to T _{smax})(ts)	Preheating time	60-120 sec	60-120 sec
Average ramp-up rate(T _{smax} to T _p)	Average rising rate	3°C/second max	3°C/second max
Liquidous Temperature (TL)	Liquid phase temperature	183°C	217°C
Time (tL) Maintained Above (TL)	Time above liquidus	60-90 sec	30-90 sec
Peak temperature (T _p)	Peak temperature	220-235°C	230-250°C
Average ramp-down rate (T _p to T _{smax})	Average descent rate	6°C/second max	6°C/second max
Time 25°C to peak temperature	Time of 25 ° C to peak temperature	6 minutes max	8 minutes max

7.2 Reflow Soldering Curve

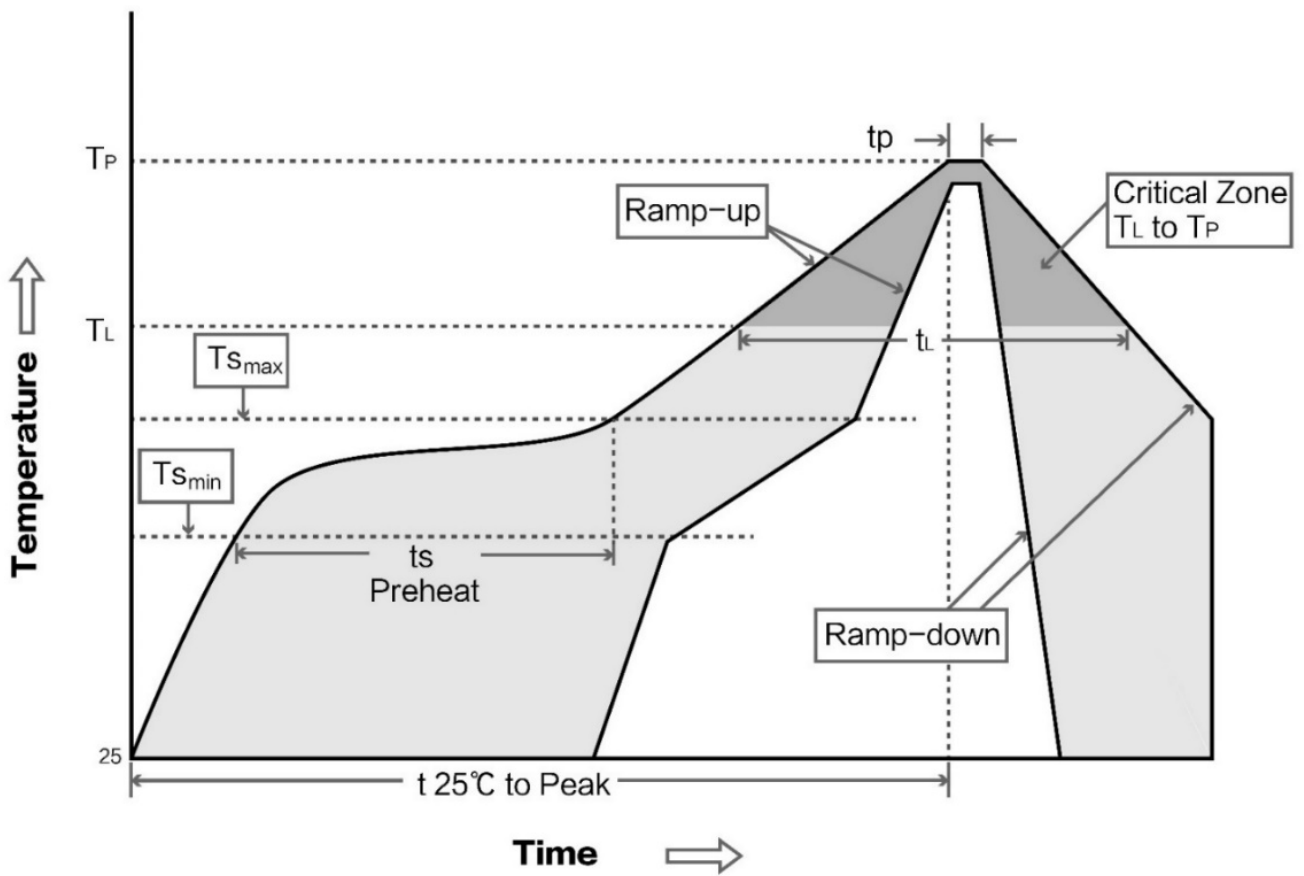

8. Related Model

Model	Chip	Frequency Hz	Transmit power dBm	Test distance km	Air Data rate	Packaging	Size mm
E22-900T22S	SX1262	868M 915M	22	7	SMD	16*26	UART
E22-230T22S	SX1262	230M	22	7	SMD	16*26	UART
E22-400T22S	SX1268	433M 470M	22	7	SMD	16*26	UART
E22-400M30S	SX1268	433M 470M	30	12	SMD	24*38.5	SPI
E22-900M30S	SX1262	868M 915M	30	12	SMD	24*38.5	SPI
E22-900M22S	SX1262	868M 915M	22	6.5	SMD	14*20	SPI
E22-400M22S	SX1268	433M 470M	22	6.5	SMD	14*20	SPI

9. Antenna Type

9.1 Antenna recommendation

The antenna plays an important role in the communication process. The inferior antenna often has a great impact on the communication system. Therefore, we recommend some antennas that support our wireless modules and have excellent performance and reasonable price.

Product	Type	Frequency Hz	Interface	Gain dBi	Size	Feeder	Features
TX433-NP-4310	Soft PCB antenna	433M	SMA-J	2	43.8*9.5mm	-	Built-in flexible FPC soft antenna
TX433-JW-5	Rubber antenna	433M	SMA-J	2	50mm	-	Flexible, Omnidirectional
TX433-JWG-7	Rubber antenna	433M	SMA-J	2.5	75mm	-	Flexible, Omnidirectional
TX433-JK-20	Rubber antenna	433M	SMA-J	3	210mm	-	Flexible, Omnidirectional
TX433-JK-11	Rubber antenna	433M	SMA-J	2.5	110mm	-	Flexible, Omnidirectional
TX433-XP-200	Sucker antenna	433M	SMA-J	4	19cm	200cm	High Gain
TX433-XP-100	Sucker antenna	433M	SMA-J	3.5	18.5cm	100cm	High Gain
TX433-XP-300	Sucker antenna	433M	SMA-J	6	96.5cm	300cm	High Gain
TX433-JZG-6	Rubber antenna	433M	SMA-J	2.5	52mm	-	Ultra short straight, Omnidirectional
TX433-JZ-5	Rubber antenna	433M	SMA-J	2	52mm	-	Ultra short straight, Omnidirectional
TX490-XP-100	Sucker antenna	490M	SMA-J	50	12cm	100cm	High Gain
TX490-JZ-5	Rubber antenna	490M	SMA-J	50	50mm	-	Ultra short straight, Omnidirectional

Revision history

Version	Date	Description	Issued by
1.00	2017/10/16	Original version	huaa
1.10	2018/5/23	Content added	huaa
1.20	2018/9/18	Model No. split	huaa

About us

Technical support: support@cdebyte.com

Documents and RF Setting download link: www.ebyte.com

Thank you for using Ebyte products! Please contact us with any questions or suggestions: info@cdebyte.com

Fax: 028-64146160 ext. 821

Web: www.ebyte.com

Address: Innovation Center D347, 4# XI-XIN Road, Chengdu, Sichuan, China