

# COVER

# Schematics Block:

Revision	Description	Date	Drawn	Checked
V10A	Initial	2018-12-29	xxx1zjxxx	

中大电机批量测试底板

# Power Block:

# Schematics Index:

# BUG

- 01 COVER
- 02 IO

	SICHUAN HUIYUAN OPTICAL COMMUNICATIONS CO.,LTD		
	Title: HY_PSMK_TEST_V10A		
Size: A3	Document Number: 01 COVER	Rev: V10A	
hyoc.com.cn	Date: Sunday, December 30, 2018	Sheet: 1 of 2	Approved
Designed	Checked	Approved	

电源输入

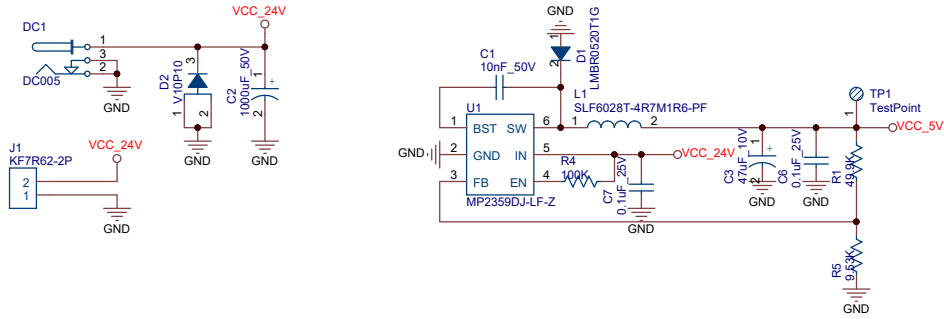

电机驱动

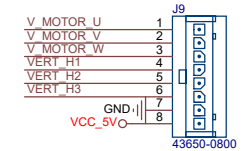
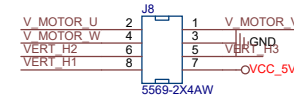
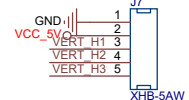
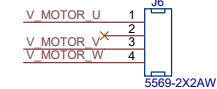
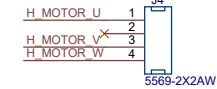
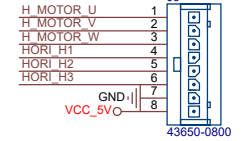
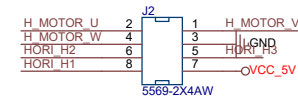
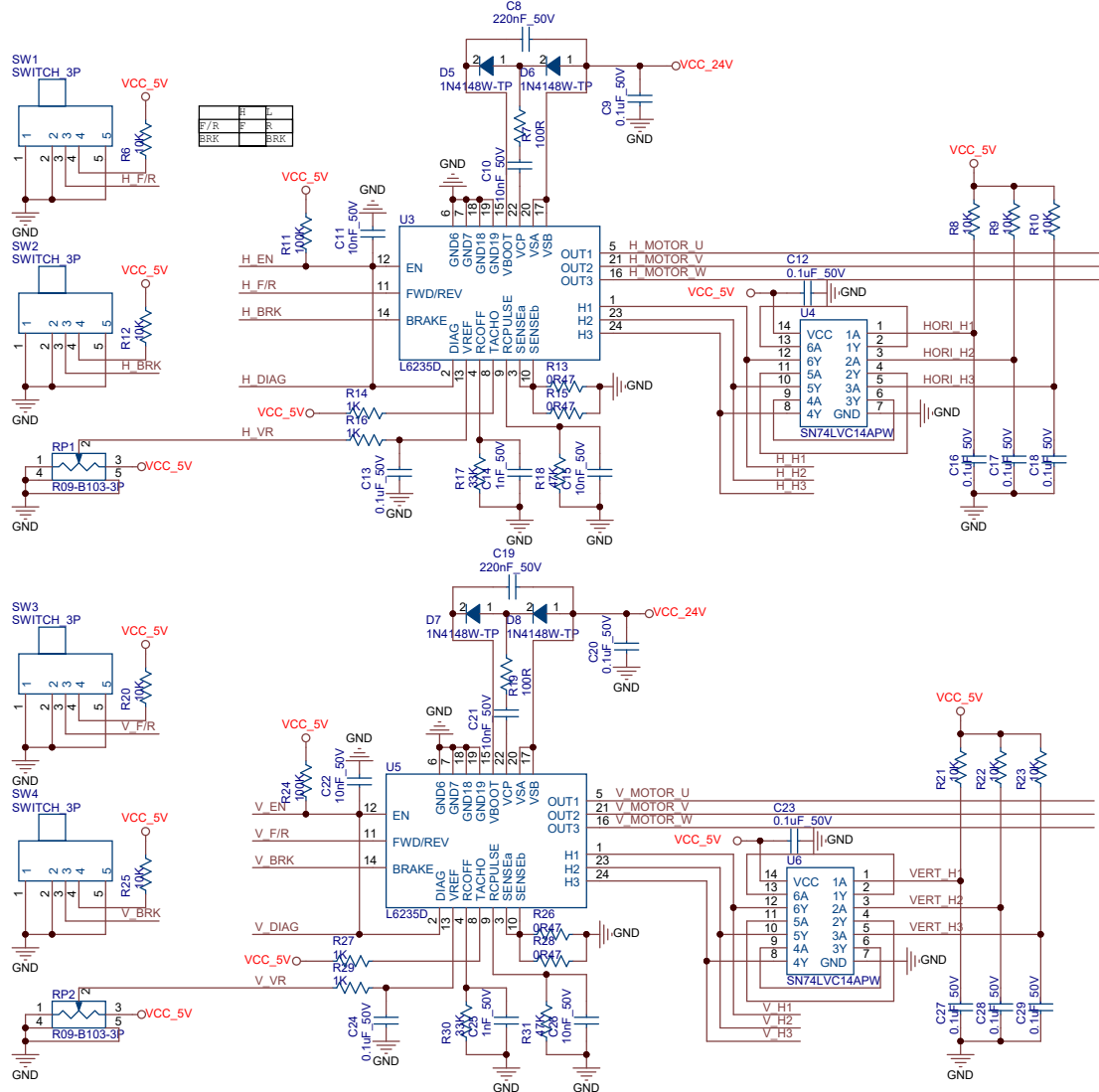

<b>SICHUAN HUIYUAN OPTICAL COMMUNICATIONS CO.,LTD</b>			
		Title HY_PSMK_TEST_V10A	
Size A3	Document Number D2 IO	Rev V10A	
Date: Sunday, December 30, 2018		Sheet 2	of 2
Designed		Checked	Approved