

BUTTONS AUDIO

Note: Using U1 internal pull-ups on all buttons

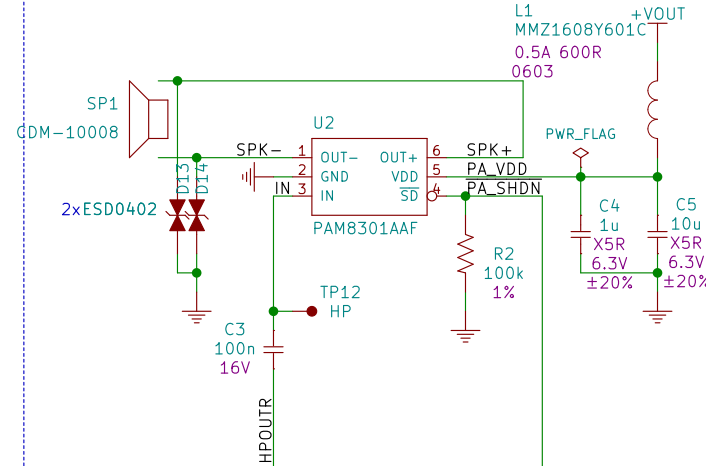

USB DEVICE

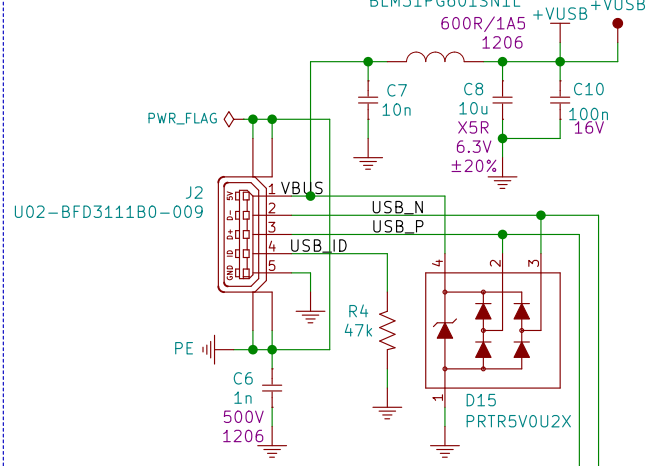

SD CARD POWER

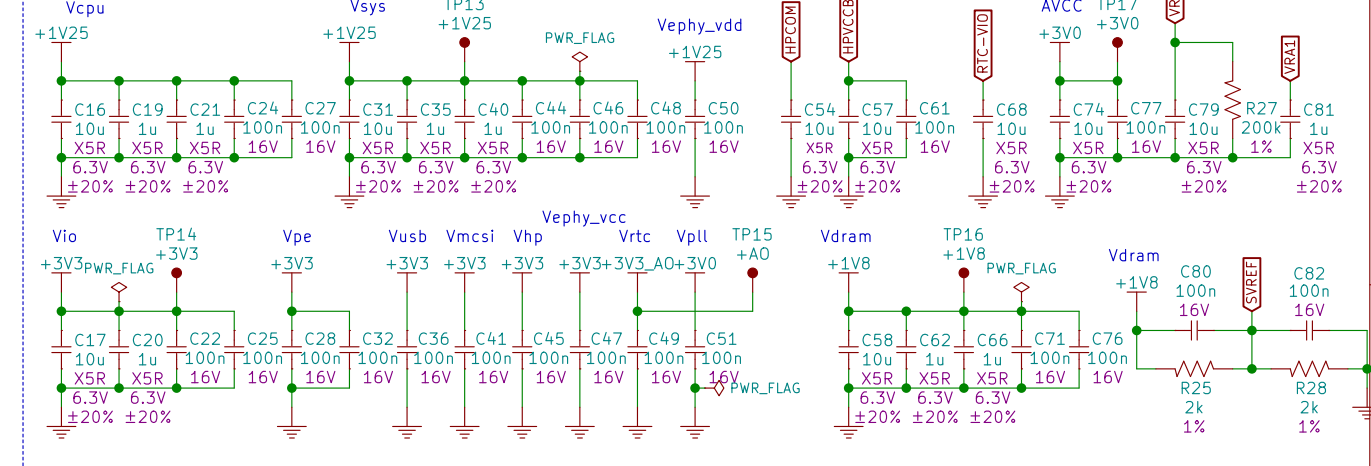

CPU PMIC

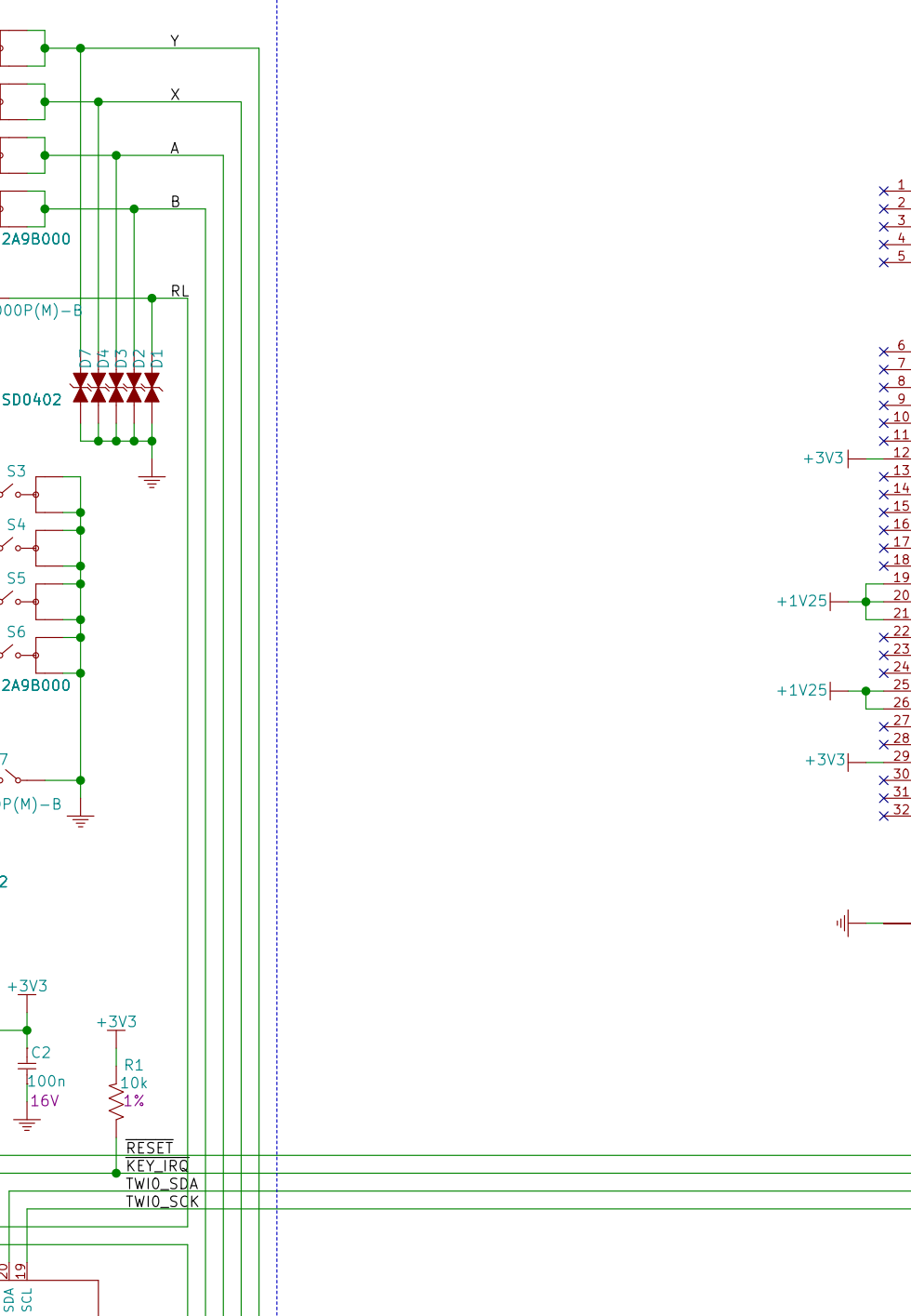
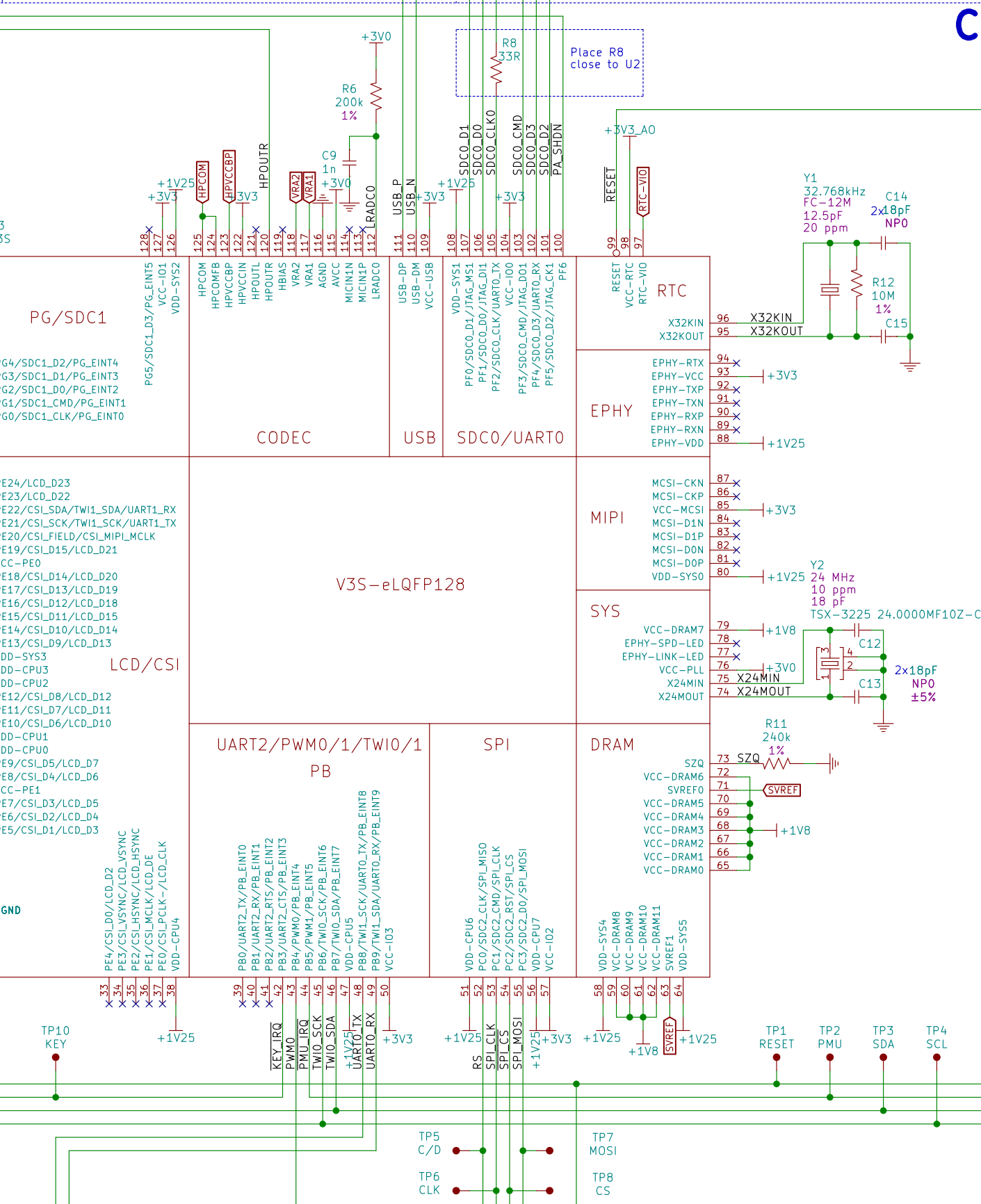
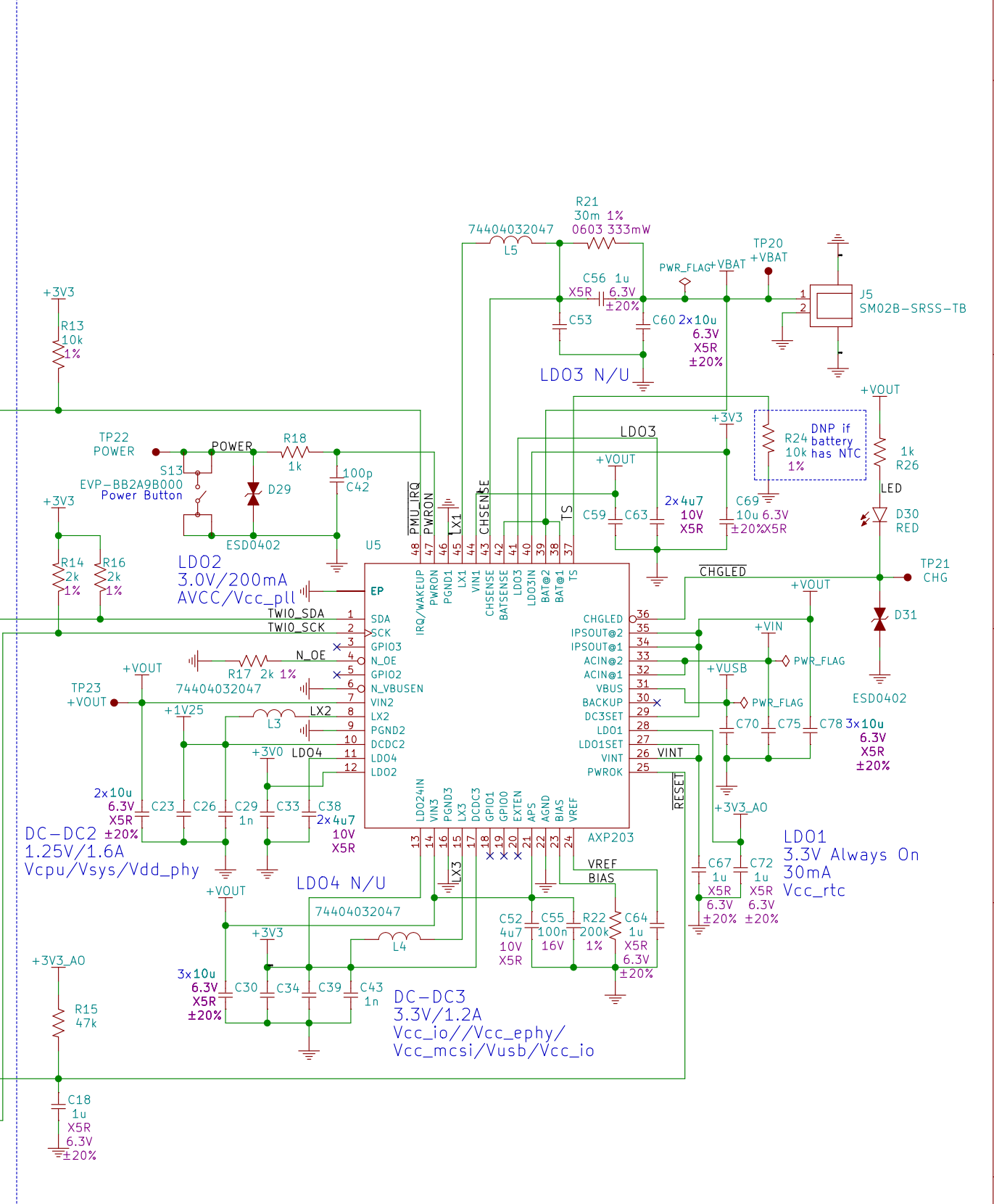

CONSOLE

SPI LCD DRAM POWER

