

# qtone

## DA-1001 20W Digital Amplifier User Manual





Thank you for your purchase of the qtone DA-1001 20W Digital Amplifier. The unit has 4 inputs as well as 2 outputs and up to 20 watts of amplification. As a digital amplifier it is very efficient (up to 93%!) While no audio is provided the amplifier uses very little power and while in use, due to its efficiency, requires no heat-sink.

The outputs can be used to connect other devices to further use the selected inputs sound. The "Audio Out" is from the selector before any tonal adjustment, meaning that it can be used to connect to another amplifier or a recording device and without adjusting the input. The "VU Out" is designed for the qtone AV-1001 Audio Visualiser, this output is after the tone controls so is representative of the signal to the amplifier.

The Amplifier also provides power out from the unit (12V up to 3 amps). Two options are available, one switched and one constant. The switched supply is turned on and off with the amplifier, useful if ancillaries are needed to be turned off with the amp. Connecting to the constant permanent supply will provide power regardless of the amplifiers state; as long as the amplifier is connected to a power source.

# Specifications

Supply Voltage	12V
Supply Current	5A
Switched Output	12V @ 3A with 8Ω   1.5A with 4Ω*
Permanent Output	12V @ 3A with 8Ω   1.5A with 4Ω*
Audio Power Output	10W per channel @ 8Ω 17W per channel @ 4Ω
Speaker connections	Spring terminal
Line Inputs	4 total      3 rear with RCA connectors 1 front with 3.5mm jack
Line Outputs	2 rear RCA    Audio Out – Before tonal controls VU Meter – After tonal controls
Volume Control	-92.8dB to +9.5dB
Tone Controls	-14dB to +14dB (2dB steps)
Balance	0dB to -72dB (in 2dB steps)
Input Gain	0dB to 30dB (in 2dB steps)
Controls	Digital      4 buttons to select input 3 buttons for tonal adjustment 1 button for balance adjustment 1 button for power

\* the outputs share power with the amplifier and each other. So there is a total of 1.5A or 3A (depending on speakers impedance) between the switched and permanent outputs.

# Unit Overview

## Front Panel Controls

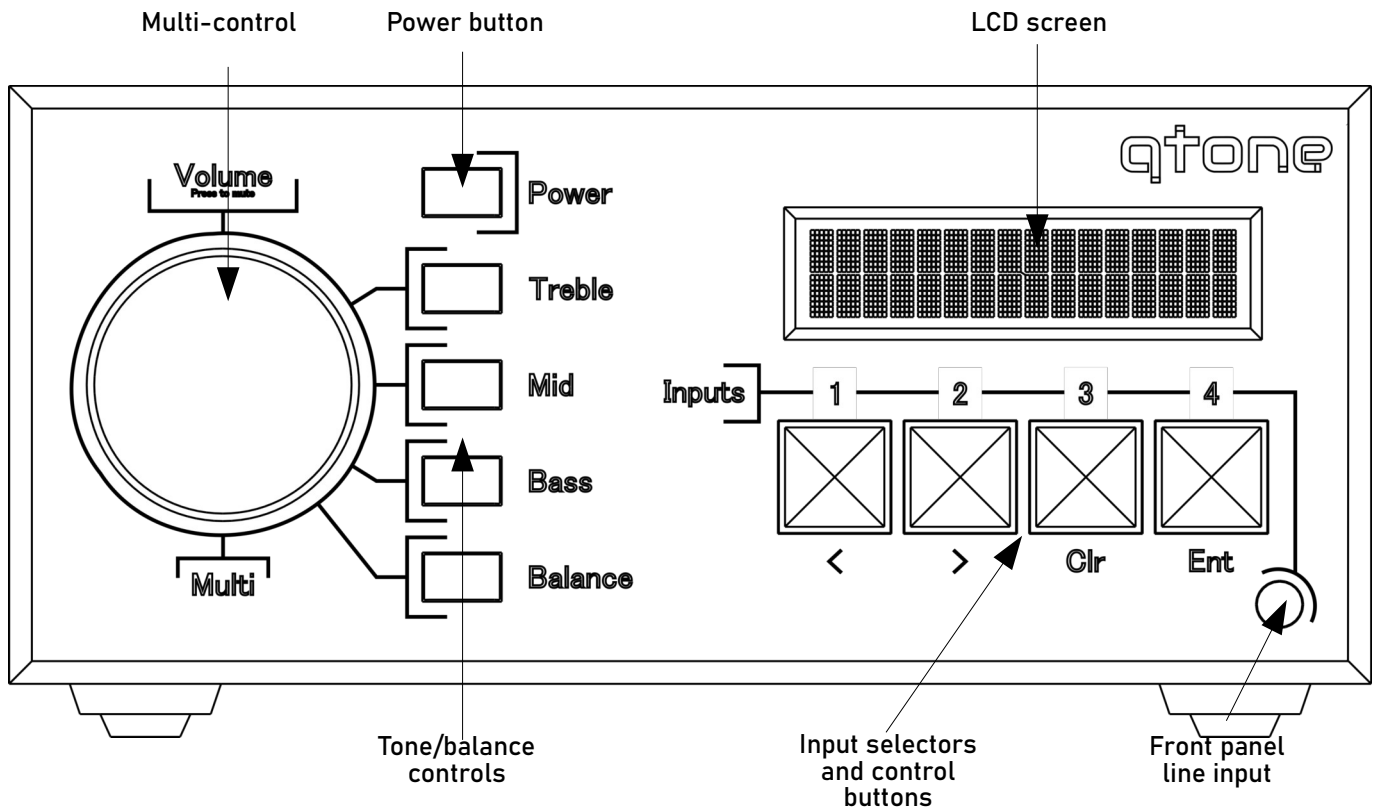

## LCD Display

Top line - Currently selected source  
(customisable name)



Bottom line - Defaults to current  
volume level. Changes depending on  
mode.

# Unit Overview

## Rear Panel Connections

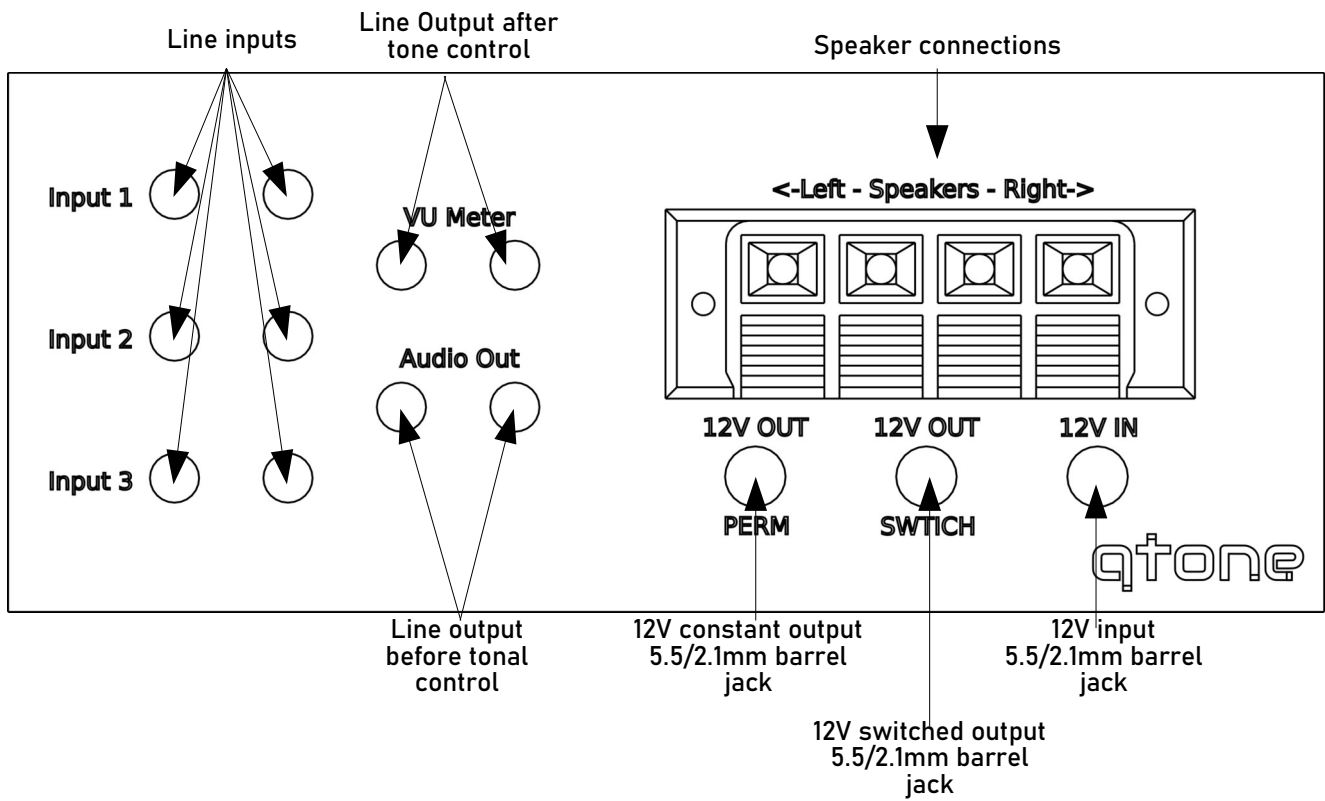

# Connection Overview

## Speakers

When connecting the speakers ensure the polarities are connected correctly (red/positive on amplifier to the red/positive on the speaker). If the speakers are connected “out of phase” (if one speaker is connected the opposite way to the other) the quality of the sound will be compromised. It will sound thin and “tinny”.

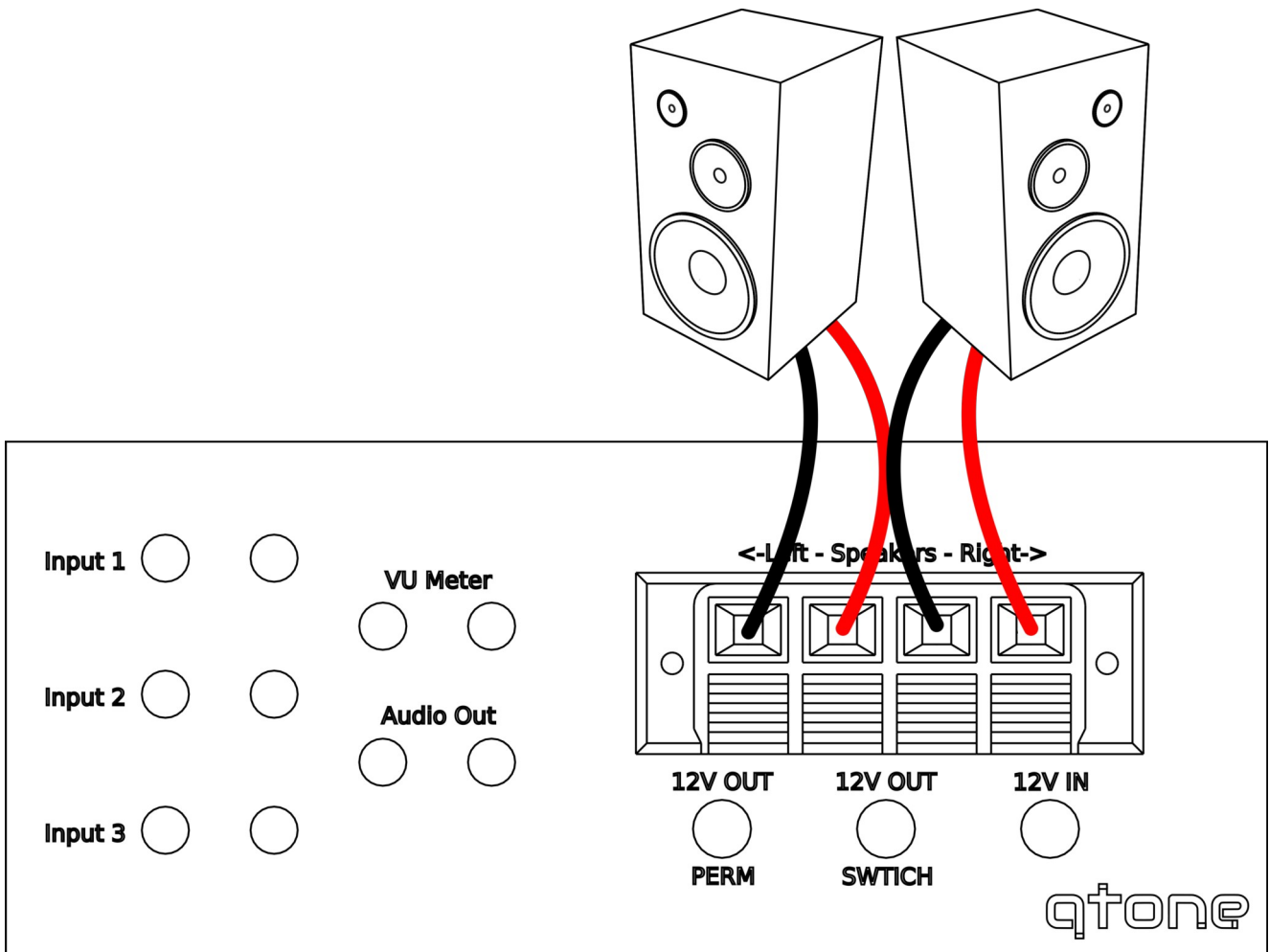

# Connection Overview

## Audio Input/Output

The connections to the amplifier are via the rear RCA phono connections. Ensure the connections are to the correct left and right sockets. Left is coloured black or white and the right channel is red.

To connect a turntable/record player you will need a pre-amp as the inputs to the DA-1001 are all 'line level'. This could be a separate device or some turntables have them built in.

The "Audio Out" can be connected to a recording device. This output is connected to the output of the selector without any tone adjustments. This will be a direct copy of the input.

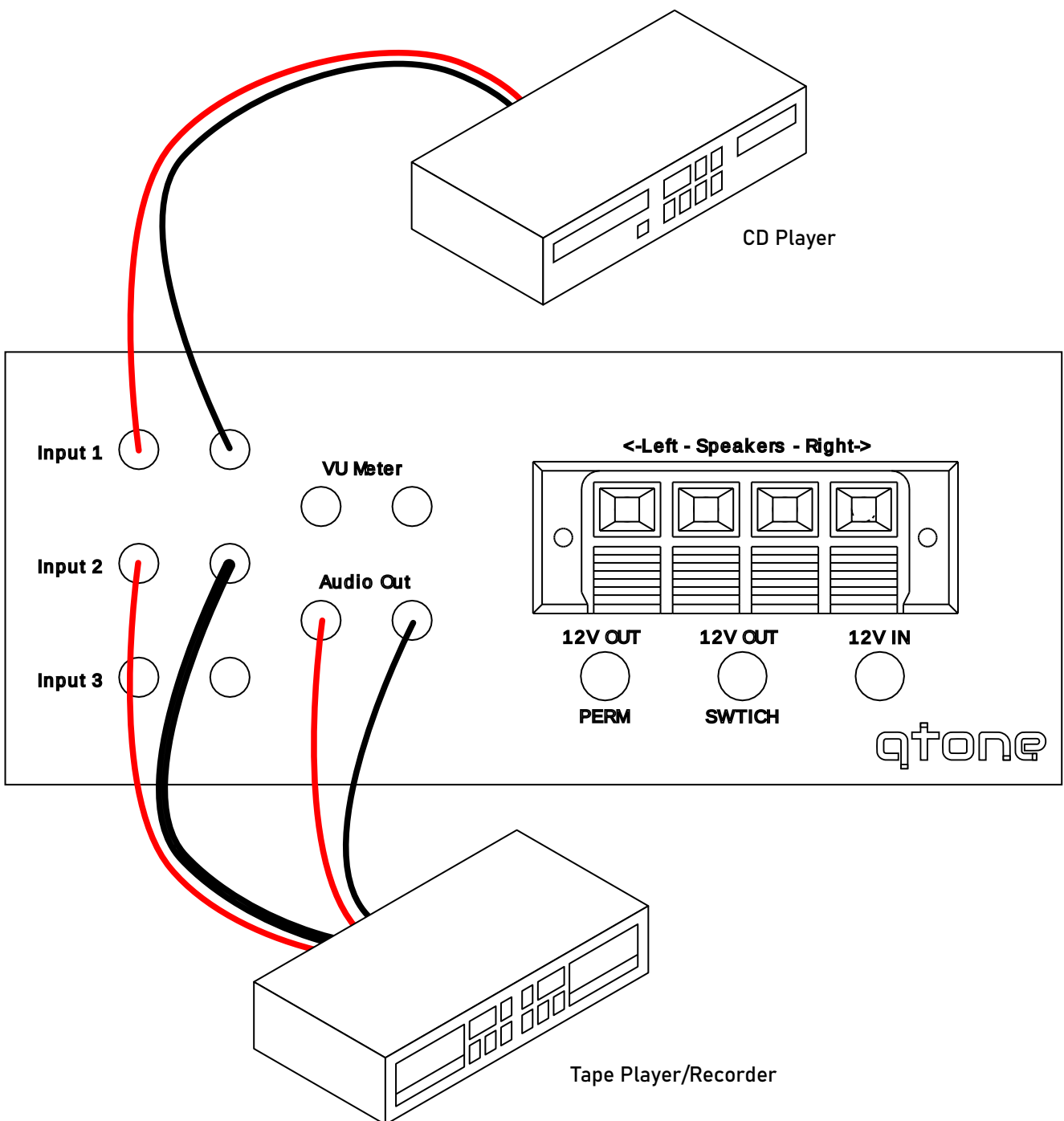

# Connection Overview

## Visualiser Audio Output

A second set of outputs are available on the rear of the amplifier. These take the audio after any tonal adjustments. It is intended for use with the qtone Audio Visualiser (AV-1001). The AV-1001 can also take power from the amplifier, using the switched output so the visualiser will turn on and off with the amplifier.

Because the audio is after tonal adjustments, the visualiser will show a representation of the audio you are listening to.

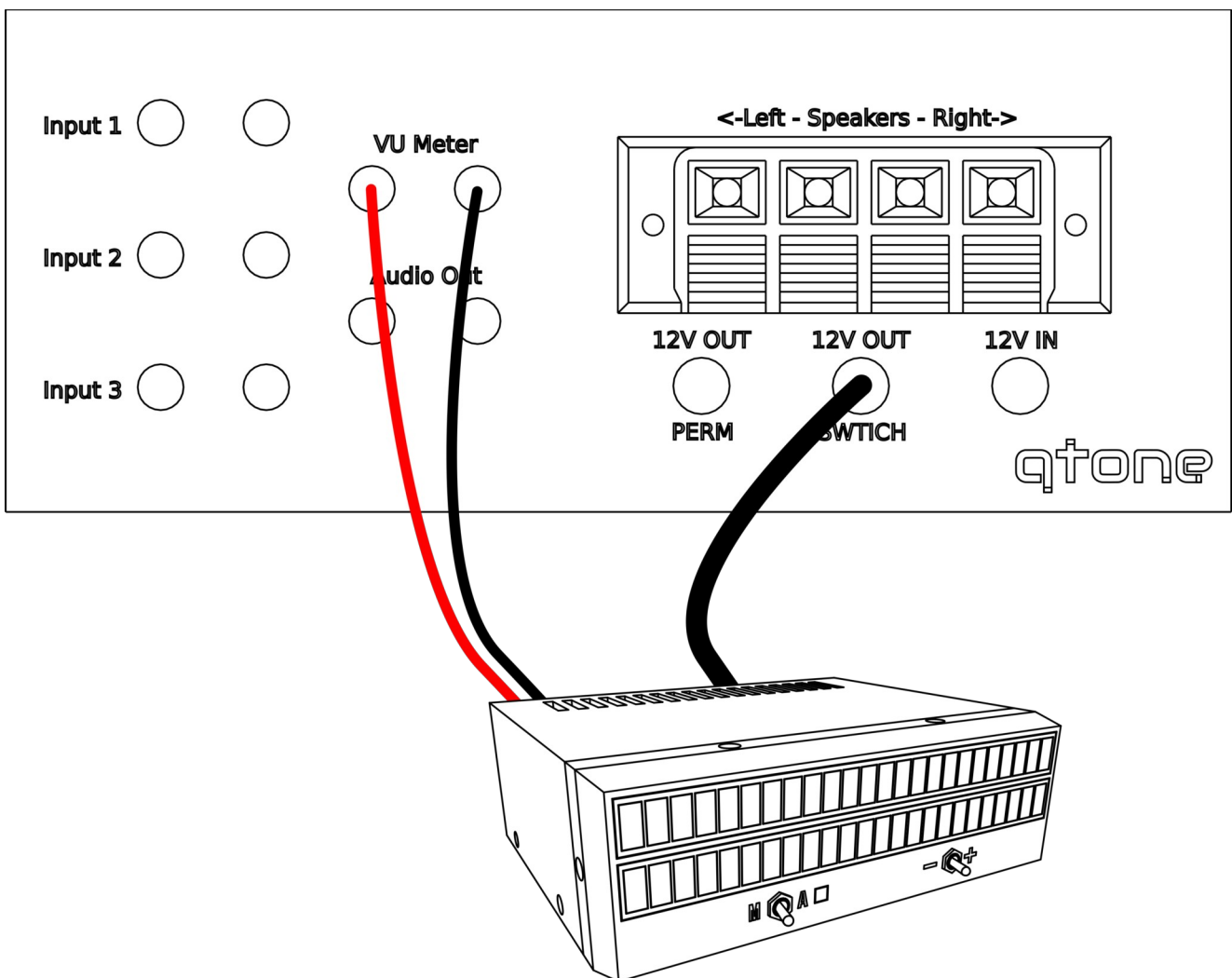



# Unit Overview

## Default Setup

When initially turned on the amplifier will be setup to default settings. All the input names are listed as Input 1-3 and Front Panel (relating to the rear input numbering and the 3.5mm jack on the front of the unit). The tone, balance controls and input pre-amp levels are all set to mid positions.

## Basic Operation

Press the Power button to turn on the unit. When the unit is turned on the LCD display will show the last selected input source as well as the current volume level. In this mode the source and volume can be changed.



## Select Inputs

Press the corresponding Input Selector button for the source required. LCD will change to display the current source number and name.

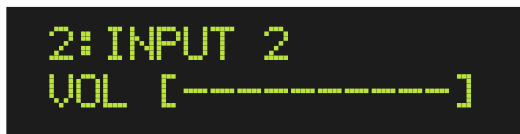
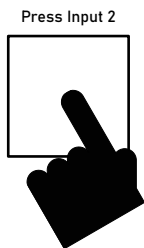

## Changing Volume

Rotate the Volume/Multi-Control to select the desired volume level, the display will update the bar-graph to the current level.

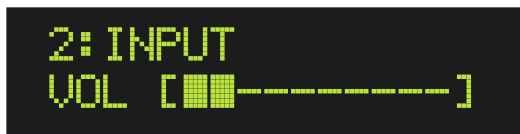
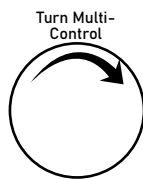
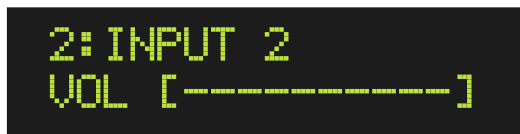

## Muting Volume

Press the Multi-Control knob to mute the audio. The display will flash between the current volume level and saying MUTE. Press the Multi-Control knob to un-mute. You can also turn the Multi-Control knob. Turning clockwise will turn the audio up from zero. Turning counter-clockwise will reduce the volume from the last setting.

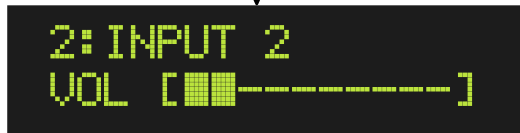
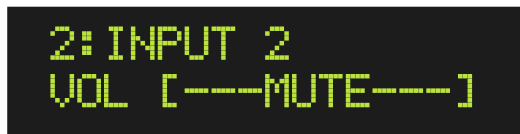
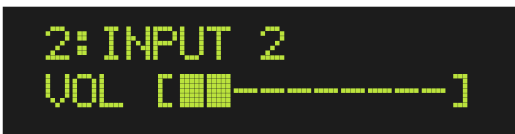

## Adjusting Tone Settings

In order change the tone settings select the the Treble, Mid-Range or Bass button. The display will show the selected control. The amplifier will return to the volume display after 5 seconds of inactivity or the same tone button is pressed again.

Press Treble

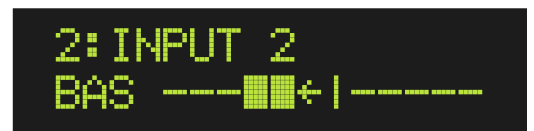
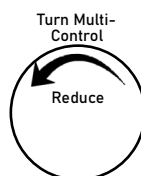
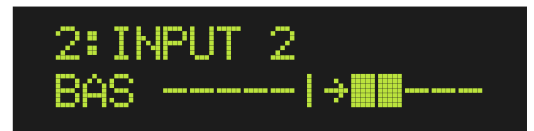
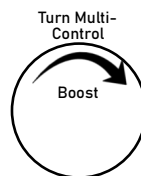
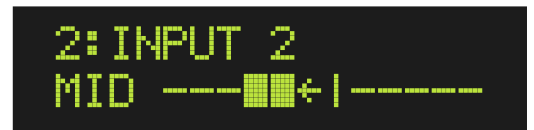
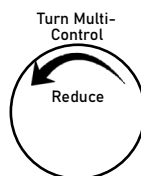
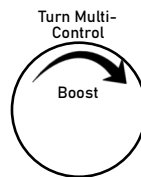
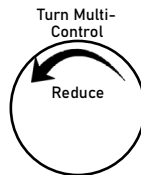
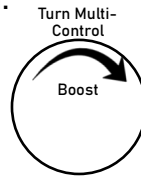
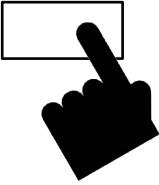

Press Mid

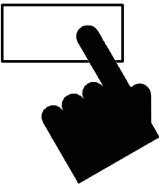

Press Bass

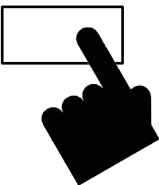

## Setting Balance

In order change the balance between the left and right speakers, press the Balance button. The display will then show the current balance setting. Turn the Multi-Control knob to adjust the balance left or right. The amplifier will return to the volume display after 5 seconds of inactivity or the same tone button is pressed again.

Press Balance

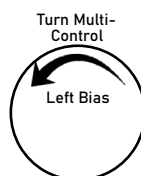
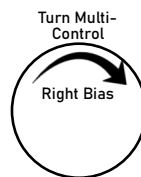
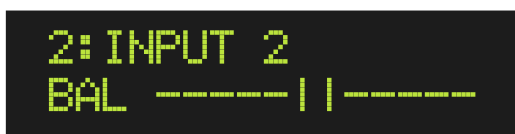
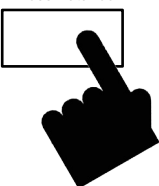

# Advanced Setup

## Changing Input Name

By default the amplifier will have the input selections named based on the input number or location. These can be changed to any 14 character name. Press and hold the input that the name is to be changed on. The display will then show a flashing cursor on the first letter of the input name. Turn the Multi-Control knob to change the letter, use the left and right arrows to move to another character, the Clr button to clear the currently selected letter and the Ent button to finish entering and confirm the name. This will return you to the main volume display.

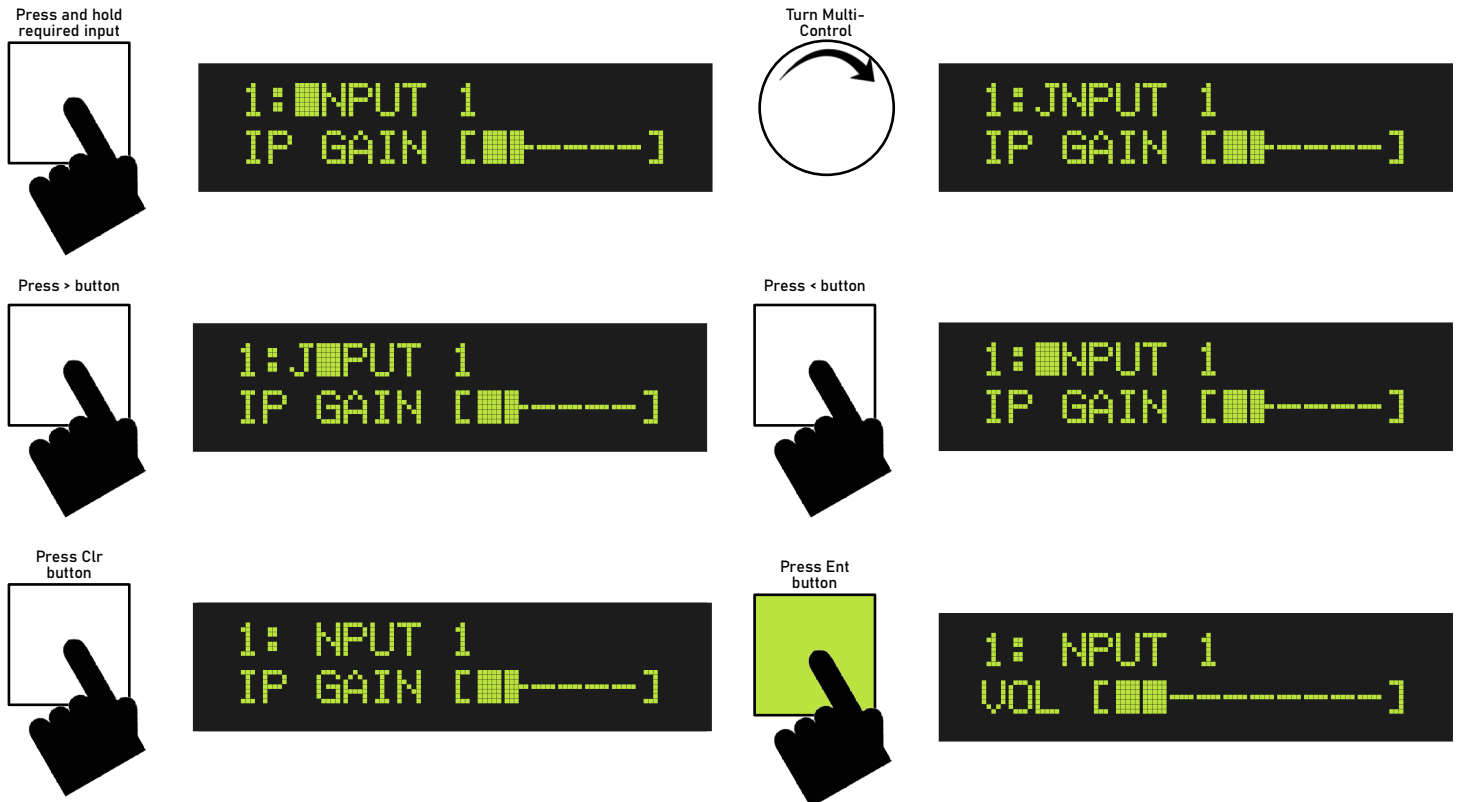

## Setting Input Source Pre-Amp

The amplifier has the ability to boost individual inputs regardless of the current volume settings. This allows for each input to be set to provide a consistent overall volume depending on a device. For example: if one source is louder than the others then it can be reduced so that you wouldn't need to adjust the master volume just for that input.

To change the pre-amp level, enter into the name change mode and then press the Multi-Control knob and turn it to adjust the gain up or down.

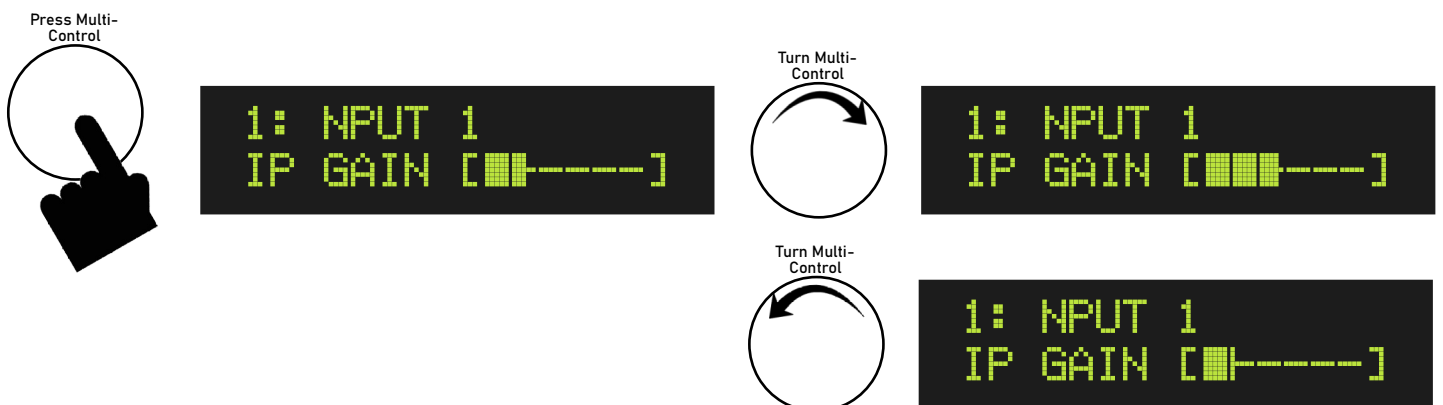

# Settings Menu

Press and hold  
required Power

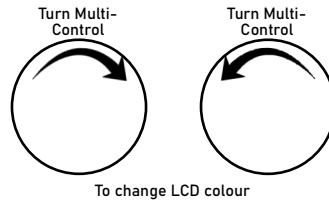
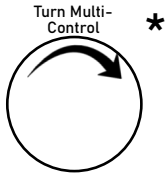

To change LCD colour

OR



To confirm

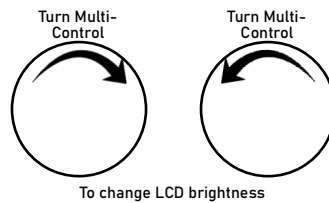
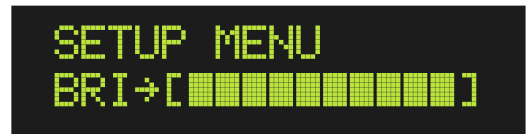
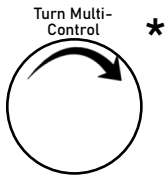

To change LCD brightness

OR



To confirm

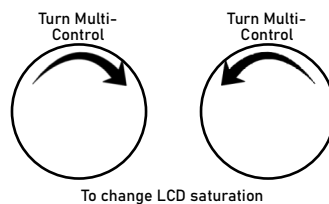
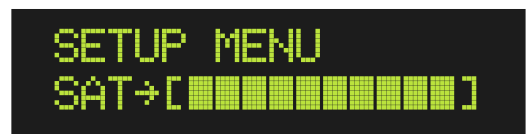
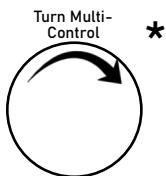

To change LCD saturation

OR



To confirm

# Settings Menu - Continued

Turn Multi-Control

SETUP MENU  
BL TIME:30 MINS

Press Multi-Control

SETUP MENU  
BL TIME:30 MINS

Turn Multi-Control

Turn Multi-Control

OR

Press Multi-Control

To confirm

To change backlight timer duration

Turn Multi-Control

SETUP MENU  
GPA: [ ]

Press Multi-Control

SETUP MENU  
GPA->[ ]

Turn Multi-Control

Turn Multi-Control

OR

Press Multi-Control

To confirm

To change global preamp level

Turn Multi-Control

SETUP MENU  
AMP: MAX3744

Press ENTER

1: INPUT 1  
VOL [ ]

## Amplifier Detection

This will show the type of amplifier detected

- MAX3744 - Adafruit Amplifier
- DA2004.4 - QTone Amp Interface
- CUSTOM - No amplifier detected

If no board is detected CUSTOM is shown and volume control will be via the tone controller. This means the 'VU Out' will be tied to the volume control and can be used to input into an external amplifier.

## Setup Menu - Layout

- VER - Firmware Version
  - Currently installed firmware
- RGB - LCD Backlight Colour\*
  - If RGB LCD backpack installed changes the colour if the LCD backlight
- BRI - LCD Backlight Brightness\*
  - If RGB LCD backpack installed changes the brightness of backlight
- SAT - LCD Backlight Saturation\*
  - If RGB LCD backpack installed changes the saturation of backlight
- BL TIME - LCD Backlight Timer
  - How long to keep backlight on after change. After this time passes dims RGB backlight or turns mono backlight off
- GPA - Global Pre-Amp
  - Sets internal volume reduction. Reduce this should audio be distorting
- AMP - Currently Detect Amplifier
  - Shows which amplifier has been detected

\* These options are only available when the RGB backpack is detected.

**Colour Options**

- 1: RED
- 2: FIRE
- 3: ORANGE
- 4: GOLD
- 5: YELLOW
- 6: LIME
- 7: GREEN
- 8: FERN
- 9: SAPPHIRE
- 10: SKY
- 11: BLUE
- 12: BERRY
- 13: PURPLE
- 14: MAGENTA
- 15: HOT PINK
- 16: STRAWBERRY

**Brightness/  
Saturation**

**\*Mono LCD**

If a mono LCD display is detected then the following will be displayed:

```

RGB: NA
BRI: NA
SAT: NA
  
```

**Backlight Time**

```

00 MINS
01 MINS
02 MINS
05 MINS
10 MINS
15 MINS
20 MINS
30 MINS
  
```

00 minutes turns off the backlight timer

Timer turns off mono LCD and reduces brightness by 50% with RGB LCD

## Factory Reset

You can reset the whole amplifier back to its factory defaults. This can be done by holding down both the Treble and Bass buttons when first applying power to the unit. It will not work when using the Power button to turn the unit on, *only when power switched on from the wall socket*. This will reset the internal memory to the following defaults:

Volume	0dB	Input Gain (all inputs)	0dB
Treble	0dB	Input 1 Name	INPUT 1
Mid-Range	0dB	Input 2 Name	INPUT 2
Bass	0dB	Input 3 Name	INPUT 3
Balance	0dB	Input 4 Name	FRONT PANEL

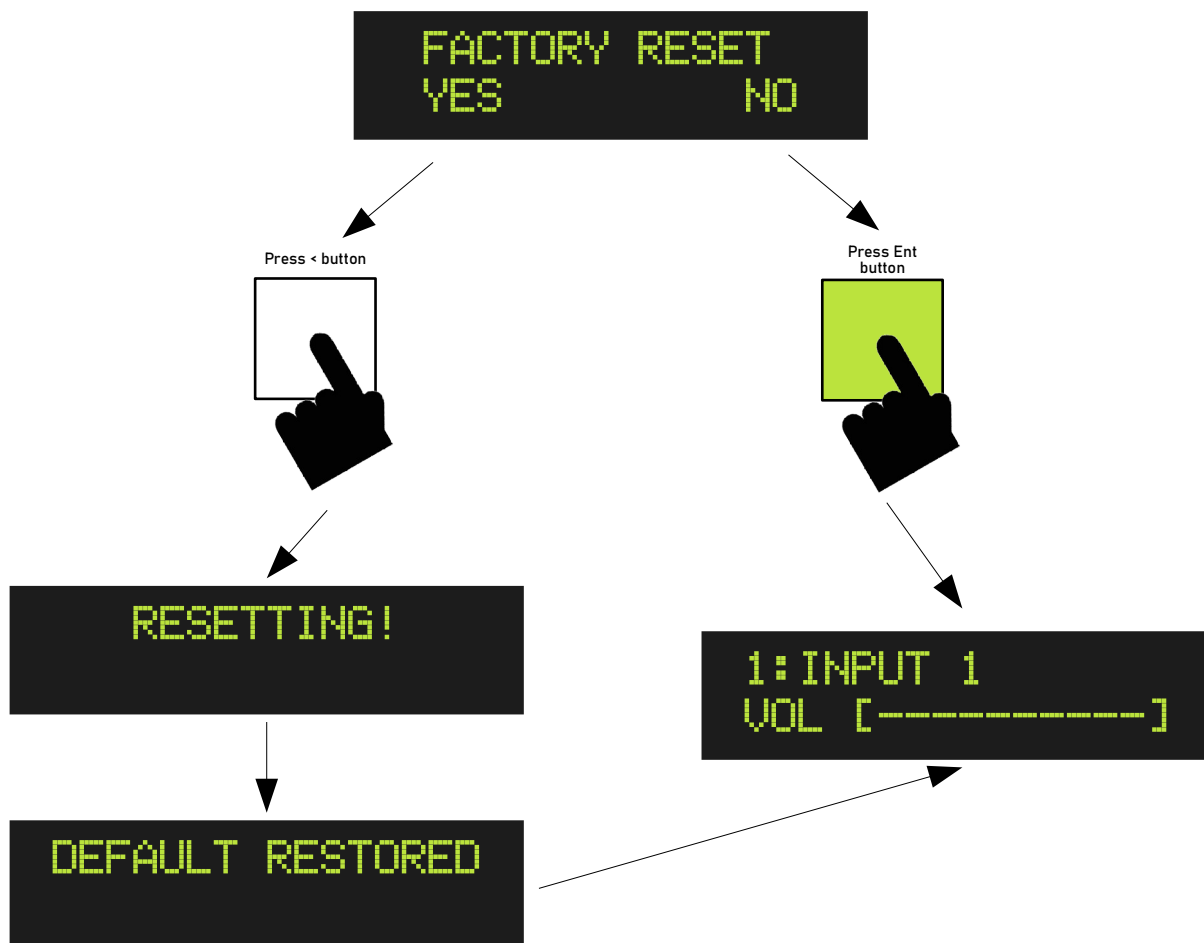
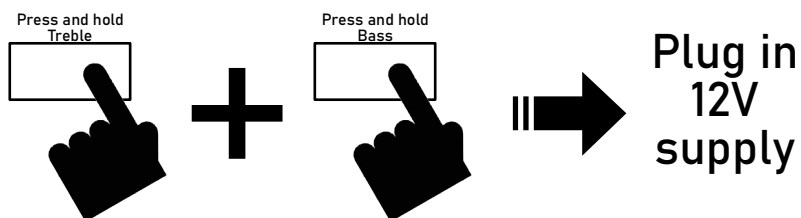

## Update Firmware/Custom Firmware

On the underside of the unit, at the front, there is a micro-USB port. This can be attached to a computer and updated using the Arduino IDE to add or change features of the unit.

When there are new firmware updates this port can be used to update/upgrade the amplifier. The qtone DA-1001 is also designed to be 'user hackable'. Because the unit uses open source hardware and software completely custom firmware can be added to the unit to change how it operates. This is for the brave only! It runs the risk of "bricking" the amplifier (although it is often possible to recover the unit).

## Compiling Firmware From Source

You can download the source code for the DA-1001 from the qtone website. You will also need to install the Arduino IDE (available from [www.arduino.cc](http://www.arduino.cc)).

To compile there are a few additional libraries that need to be installed:

- 1) Encoder
- 2) Bounce2
- 3) LiquidCrystal\_I2C

All of these can be installed using the Arduino's "Library Manager" in the "Sketch" menu.

- Connect the amplifier to the computer and in the "Tools" menu click Board and select "Arduino Nano"
- Select the correct COM port (see above if unsure)
- Finally click the "Right Arrow" button to compile and upload the firmware.









