

DATE	DESCRIPTION	REV.
10.08.13	CHANGE AS PER ECN 13-091	A
3.30.17	CHANGE AS PER ECN 17-028	B

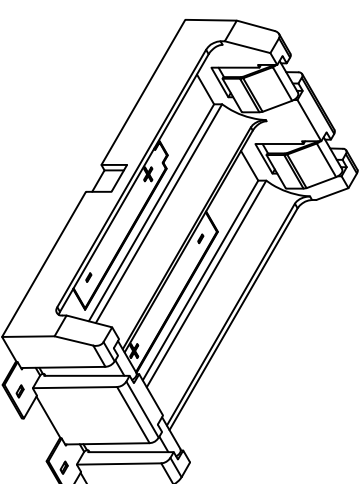
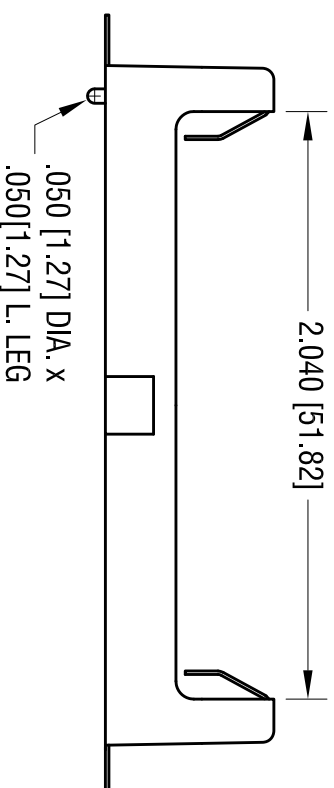
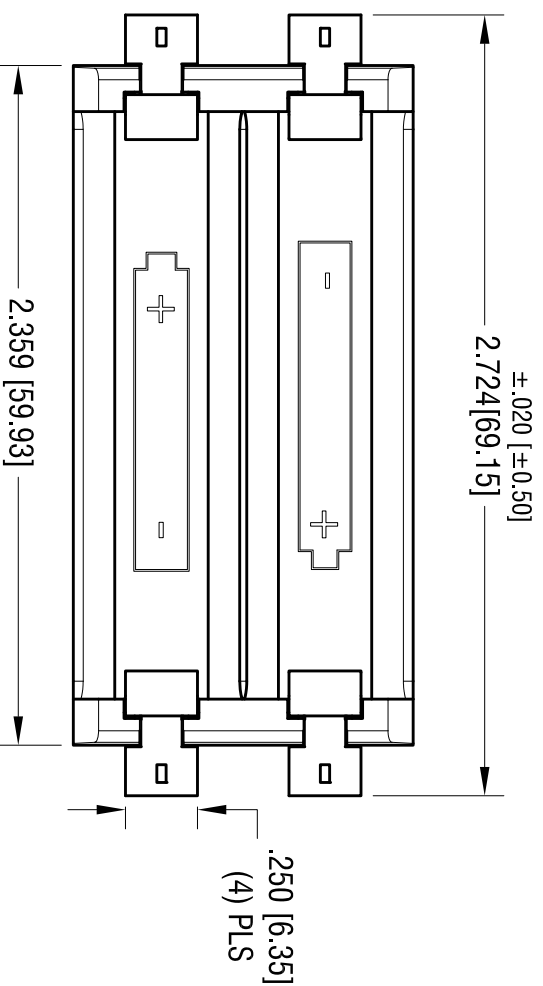
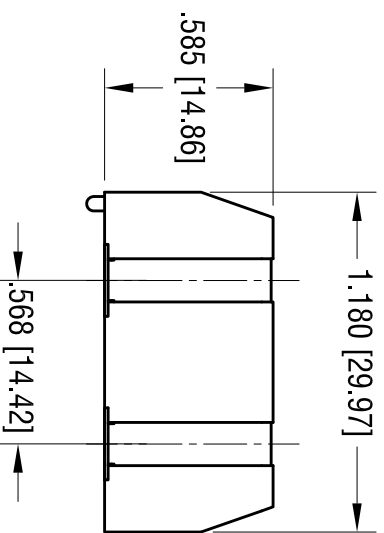
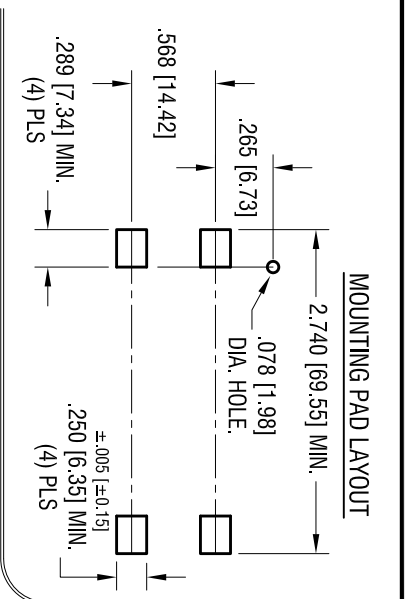

- NOTE:
1. BASE:
MATEL: HEAT RESISTANCE NYLON
(UL 94V-0)
 2. CONTACT:

MATEL: .012 [0.30] THK STAINLESS STEEL
FINISH: GOLD FLASH, OVER NICKEL PLATE.

KEYSTONE ELECTRONICS CORP.

www.keystone.com • ASTORIA, N.Y. 11105-2017 • Tel (718) 956-8900

PART NAME

SM BATTERY HOLDER, (2) AA

MATERIAL

AS NOTED

FINISH

AS NOTED

TOLERANCES	INCH	[MM]	CODE	DWG NO.
DECIMAL	± .010	[± 0.25]	C	
ANGULAR	± 1°			

1012

THIS DOCUMENT IS THE PROPERTY OF KEYSTONE ELECTRONICS CORP. AND SHALL NOT BE REPRODUCED, DISTRIBUTED OR USED AS A BASIS FOR MANUFACTURE WITHOUT PRIOR WRITTEN PERMISSION FROM KEYSTONE ELECTRONICS CORP.