

ALL IMPEDANCE CONTROLLED LINES ARE VERY SENSITIVE TO JITTER AND IMPEDANCE VARIATIONS!
 COPLANAR WAVEGUIDES MUST MEET TIGHT IMPEDANCE VARIATION TOLERANCE TO SUPPRESS REFLECTIONS!

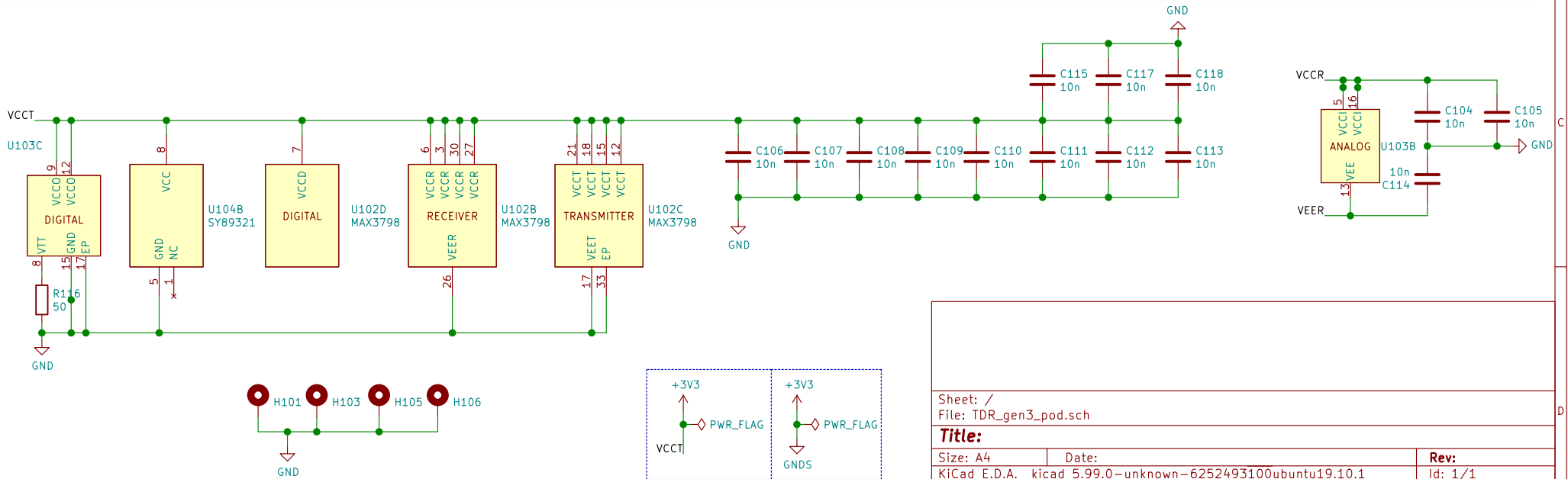
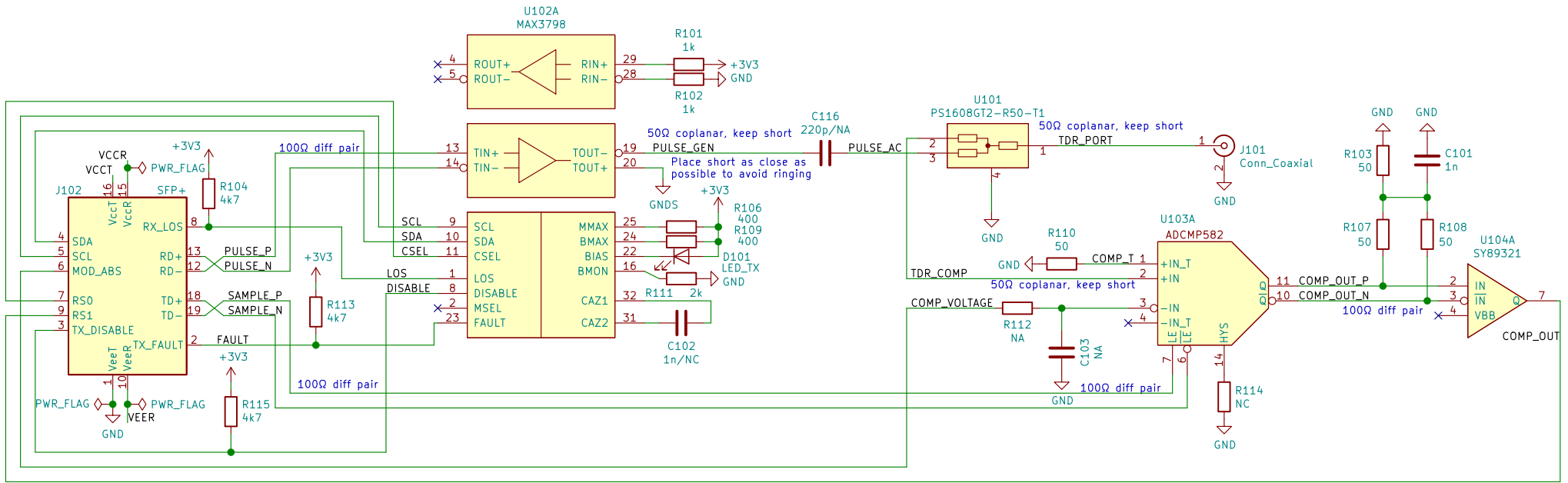

Sheet: /		Date:	
File: TDR_gen3_pod.sch		Rev:	
Size: A4	KiCad E.D.A. kicad 5.99.0-unknown-625249310ubuntu19.10.1		Id: 1/1