

# Educational Five-Bar Parallel Robot

Xavier Cano-Ferrer

**Abstract**—The present paper describes the design of an educational five-bar parallel robot based on the Teensy microcontroller. The small size of the robot and the simplicity of its components makes it suitable for its easy reproduction and programming.

## I. INTRODUCTION

Five-bar parallel robots have been studied in academia for years. Some of their most common applications are: drawing [1] [2] or engraving and manipulation [3] [4]. The presented desktop sized five-bar parallel robot (Figure 1) can be fully laser cut, manufactured in one day and programmed using the Arduino IDE and Teensyduino. For these reasons, it can be a good model to learn robotics concepts. The robot actuators are two stepper motors Nema 17. The motors are driven by two A4988 Stepper Motor Driver Carrier, Black Edition [5]. A Teensy 3.2 microcontroller [6] is the programmable “brain” of the robot. Two limit switches [7] are located on the limits of the workspace of the robot and are used to perform the homing sequence of the robot. A PCB has been designed to operate the robot. All the dxf., step., stl. and Gerber files can be download from the Hackaday project’s page. The project started with a preliminary design based on two Pololu 37D 50:1 geared brushed DC motors sharing their shafts with two rotary incremental encoders. In this first design, the encoders were used to implement a PID position controller for each actuated joint. The control algorithm was programmed on an Arduino Mega 2650 and the motors were driven by the Pololu Dual MC33926 Motor Driver Arduino Shield. On the second design, the brushed DC motors were replaced by stepper motors and the third design is a hybrid of both. The robot is still designed to be operated with the teensyStep library but it has the incremental encoders coupled with the motor

shafts to be able to record desired trajectories. All the information of the three designs can be found on the Hackaday project page [8]. In this article the third design will be treated.

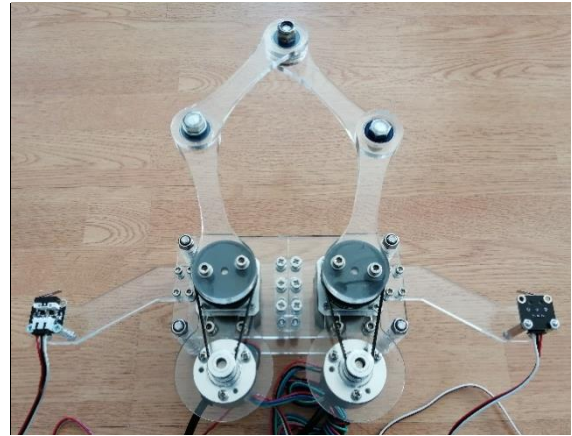

Figure 1: Five-bar parallel desktop robot manufactured and assembled.

## II. FORWARD KINEMATICS

The forward kinematic equations have been adapted from Vathan et al. [9]. The equations can be used on the program of the robot to evaluate the position of the end effector of the robot for the given angles  $q_1$  and  $q_2$  (Figure 2).

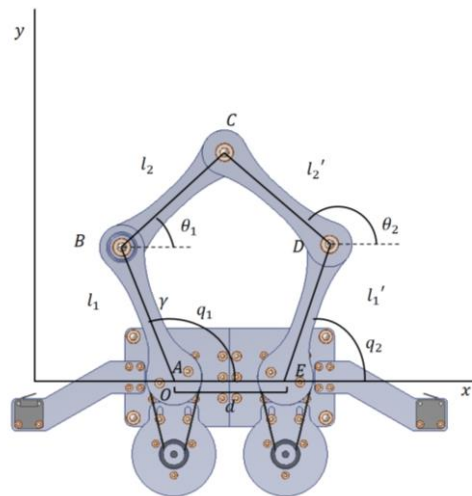

Figure 2: Forward kinematics diagram of the robot.

The position of the end effector can be calculated using the equations:

$$x_c = l_1 \cos q_1 + l_2 \cos \theta_1 = d + l_1' \cos q_2 + l_2' \cos \theta_2$$

$$y_c = l_1 \sin q_1 + l_2 \sin \theta_1 = l_1' \sin q_2 + l_2' \sin \theta_2$$

The joints B and D are not actuated by the stepper motors. For that reason the angles  $\theta_1$  and  $\theta_2$  are dependant and  $q_1$  and  $q_2$  are independent:

$$\theta_1 = \sin^{-1} \left( \frac{l_2' \sin \theta_2 + l_1' \sin q_2 - l_1 \sin q_1}{l_2} \right)$$

$$\theta_2 = 2 \tan^{-1} \left( \frac{A \pm \sqrt{A^2 + B^2 - C^2}}{B - C} \right)$$

The value of A, B and C is found using the expressions:

$$A = 2l_2' l_1' \sin q_2 - 2l_1 l_2' \cos q_1$$

$$B = 2l_2' d - 2l_1 l_2' \cos q_1 + 2l_2' l_1' \cos q_2$$

$$C = l_1^2 - l_2^2 + l_1'^2 + l_2'^2 + d^2 - l_1 l_1' \sin q_1 \sin q_2 - 2l_1 d \cos q_1 + 2l_1' d \cos q_2 - 2l_1 l_1' \cos q_1 \cos q_2$$

### III. INVERSE KINEMATICS

The inverse kinematics equations return the values of the angles  $q_1$  and  $q_2$  for each value  $[x,y]$  of the workspace of the robot (Figure 3). These two equations have been obtained using geometric methods. The robot essential dimensions to calculate the inverse kinematics can be summarized on figure 3. The inverse kinematics have been adapted from the RepRap blog of parallel SCARA 3D printer build [10] and on Shen et al. conference paper [11].

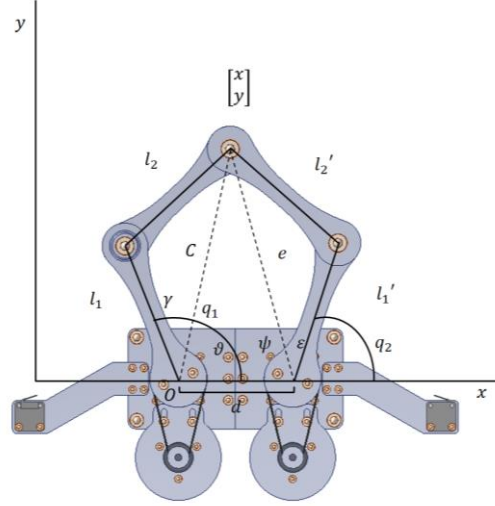

Figure 3: Inverse kinematics diagram of the robot.

$$l_1 = l_2 = l_1' = l_2' = 100 \text{ mm}$$

$$d = 80 \text{ mm}$$

*Left side*

$$C = \sqrt{x^2 + y^2}$$

$$\vartheta = \tan^{-1} \left( \frac{y}{x} \right)$$

$$q_1 = \vartheta + \gamma$$

Applying the cosine rule:

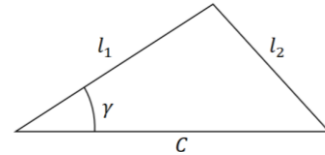

$$l_2^2 = l_1^2 + C^2 - 2l_1 C \cos(\gamma)$$

$$\gamma = \cos^{-1} \left( \frac{-l_2^2 + l_1^2 + C^2}{2l_1 C} \right)$$

$$q_1 = \tan^{-1} \left( \frac{y}{x} \right) + \cos^{-1} \left( \frac{-l_2^2 + l_1^2 + C^2}{2l_1 \sqrt{x^2 + y^2}} \right)$$

*Right side*

$$e = \sqrt{(d-x)^2 + y^2}$$

$$\psi = \tan^{-1} \left( \frac{y}{d-x} \right)$$

$$q_2 = \pi - \epsilon - \psi$$

Applying the cosine rule again:

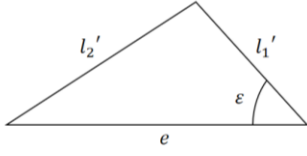

$$l_2'^2 = l_1'^2 + e^2 - 2l_1'e \cos(\varepsilon)$$

$$\varepsilon = \cos^{-1}\left(\frac{-l_2'^2 + l_1'^2 + e^2}{2l_1'e}\right)$$

$$q_2 = \pi - \tan^{-1}\left(\frac{y}{d-x}\right) - \cos^{-1}\left(\frac{-l_2'^2 + l_1'^2 + e^2}{2l_1'\sqrt{(d-x)^2 + y^2}}\right)$$

The workspace of the robot can be configured using different modes. This has been studied and implemented on the DexTAR Robot [4] and Tien Dung et al. [12]. These modes are summarized as follows:

- Mode "+-":  $q_1 = \vartheta + \gamma$  and  $q_2 = \pi - \psi - \varepsilon$
- Mode "-+":  $q_1 = \vartheta - \gamma$  and  $q_2 = \pi - \psi + \varepsilon$
- Mode "--":  $q_1 = \vartheta - \gamma$  and  $q_2 = \pi - \psi - \varepsilon$
- Mode "++":  $q_1 = \vartheta + \gamma$  and  $q_2 = \pi - \psi + \varepsilon$

The robot program works with mode "+-" by default but this can be changed on the inverse kinematic functions in order to get the desired behaviour.

#### IV. ELECTRONICS

The two drivers have the three mode pins (M0, M1 and M2) pulled-up (connected to the Teensy 3.3V pin) so the robot works by default with the 3200 steps per revolution resolution. Two 100  $\mu$ F capacitors are connected to the VMOT pins in order to protect the driver from spikes. The working voltage of the encoders is supplied by a LM7805 voltage regulator (Figure 4). The intention of the third switch is to have an input to tell the robot when you want to use the encoders to record a trajectory to reproduce it afterwards.

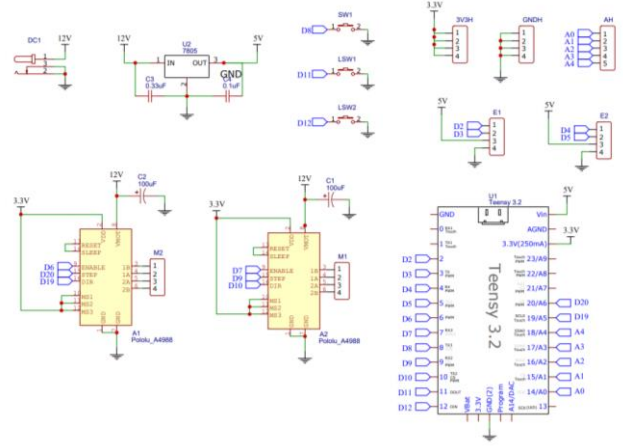

Figure 4: Proposed schematic of the Robot including the two stepper motors, two limit switches, Pololu A4988, two encoder connections, one switch and the Teensy 3.2.

#### V. TIMING BELT DESIGN

The number of teeth  $z_p$  of the big and the small pulley have been adjusted to get a gear ratio of 3:1 where the number of pulses per revolution of the encoder is increased in a factor of three. In the case of the selected encoders, from 600 pulses/revolution to 1800 pulses per revolution. Due to the dimensions of the robot, the adequate size of the timing belt is the GT2. Therefore, the pitch is 2.032 mm.

$$d_p = \frac{p z_p}{\pi}$$

Once the big and small pulley diameters defined ( $D$  and  $d$ ) the distance between both  $C$  has been calculated in order to get the desired commercial length  $L$ :

$$L = 2C + \frac{\pi}{2}(D + d) + \frac{(D - d)^2}{4C}$$

The length obtained is 192.95 mm and a commercial and suitable option is the: RS PRO, Timing Belt, 95 Teeth, 193.04 mm length and 6mm Width [13]. The encoders can be added as an additional feature because the encoder holder can be attached to the motor holder using two M4 screws. The belt tension can be adjusted by translating the encoder holder before tightening the screws.

## VI. BILL OF MATERIALS AND ASSEMBLY INSTRUCTIONS

The bill of materials can be found on the Hackaday project's page as well as the assembly instructions with good resolution [8].

They are summarized in nine steps:

- 1- Assembly of the stepper motors with their holders.

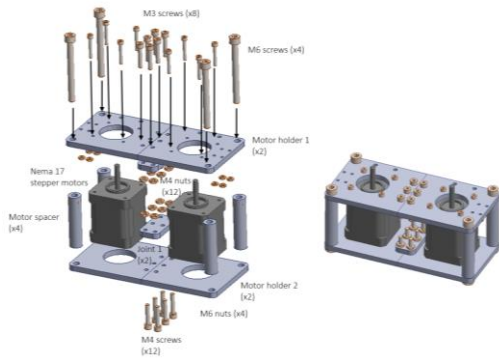

- 2- Limit switch holder's assembly.

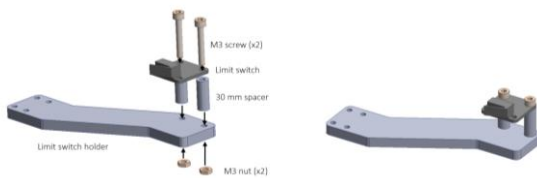

- 3- Arms assembly.

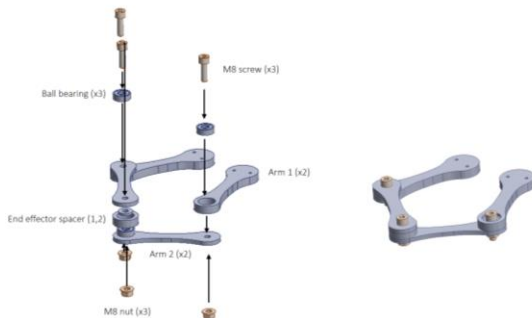

- 4- Assembly of the limit switches with the motors.

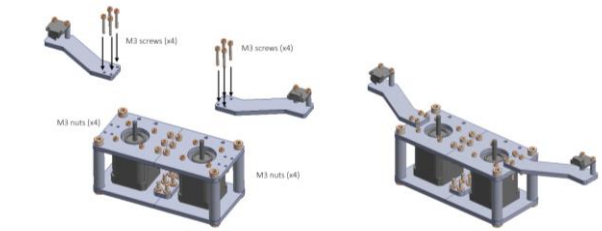

- 5- Assembly of the large pulleys.

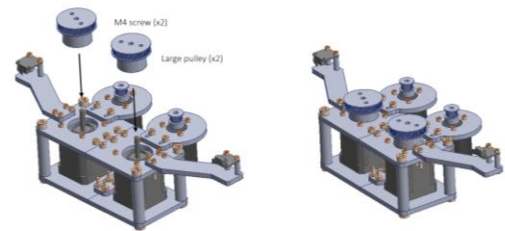

- 6- Assembly of the encoders with the robot.

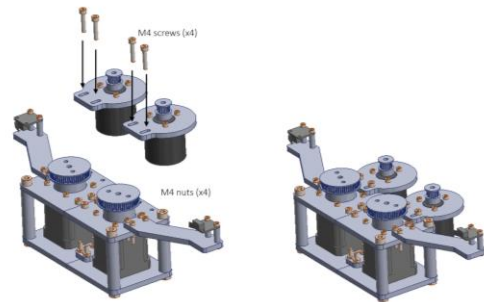

- 7- Assembly of the encoders with their holders.

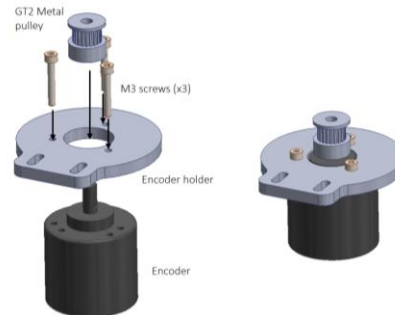

8- Timing belts assembly.

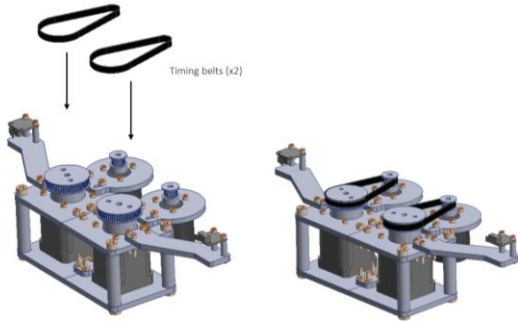

9- Assembly of the arms with the rest of the robot.



## VI. BASIC PROGRAM

The robot is intended to use the TeensyStep library [14]. Which is perfect to manage several motors making a synchronous movement and also work with a huge range of speeds and accelerations (up to 300,000 steps/s and 500,000 steps/s<sup>2</sup>) to get precise and fast movements to the robot. The homing procedure starts moving both arms to the right side until the right arm reaches the right end switch. Then the robot starts rotating both arms counter clock wise and counting the number of steps that the right arm is doing. When the left arm reaches the left end switch, both motors stop, the number of steps is converted to an angle and the left arm angle is set to 180 degrees. After the homing procedure, the end effector is moved on the position [40,170] and from that position is called to draw a small rectangle. A basic program of the robot drawing a square can be seen on YouTube [15].

## VII. RESULTS

The Parallel robot has been designed to use the 3200 steps per revolution configuration. With this

configuration, the theoretical resolution is 0.1125 degrees per step. The repeatability test has been measured in the x and y axes ( $N = 18$ ,  $\omega = 56.25 \text{ }^\circ \cdot \text{s}^{-1}$  and  $\alpha = 112.5 \text{ }^\circ \cdot \text{s}^{-2}$ ) using a KATSU Dial Test Indicator [16]. The repeatability (RP) has been calculated using the equations proposed by Barrientos et al. where  $Lm$  and  $Ls$  are the average and the standard deviation of all the distances reached from the barycentre ( $L_j$ ) [17]:

$$L_j = \sqrt{(x_j - xm)^2 + (y_j - ym)^2}$$

$$Lm = \frac{\sum L_j}{n - 1}$$

$$Ls = \sqrt{\frac{\sum (L_j - Lm)^2}{n - 1}}$$

$$RP = Lm + 3Ls$$

The repeatability (RP) obtained with the experimental results has been 0.1147 mm. This value corresponds to the cyan circle diameter (Figure 6).

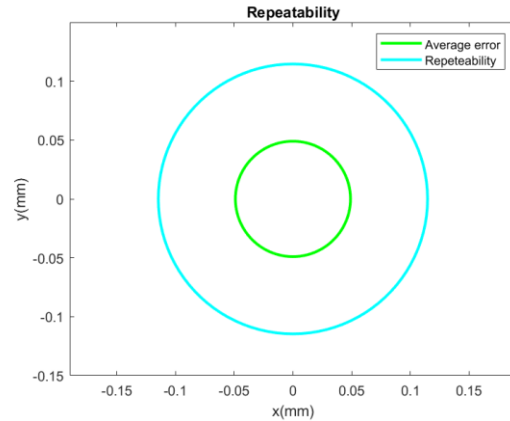

Figure 6: Repeatability and average error plot.

The repeatability test for the y axis can be seen on the YouTube channel [18].

## VIII. DISCUSSION

This robot can be easily manufactured and assembled in a few hours. All the components are accessible and inexpensive.

The basic robot tools can be subject of study with this robot are: forward and inverse kinematics, homing sequence, stepper motor speed and acceleration profiles, closed loop position control algorithms (P, PI, PD, PID) and trajectory recording. For all this reasons this tool can be suitable to use in educational workshops for adults or practical lessons in engineering schools.

#### REFERENCES

- [1] “<https://www.thingiverse.com/thing:248009>,” [Online].
- [2] F. Cemal and I. Katip, “Real time controlled two dof five bar robot manipulator,” in *Proceedings of the International Symposium of Mechanism and Machine Science*, Baku, 2017.
- [3] N. Siltala, A. Vuola, R. Heikkilä and R. Tuokko, “A H-scara mini robot - a dual parallel kinematics mini manipulator,” in *Proceedings of the joint conference of the 41st International Symposium on Robotics*, Munich, 2010.
- [4] L. Campos, F. Bourbonnais, I. A. Bonev and P. Bigras , “DEVELOPMENT OF A FIVE-BAR PARALLEL ROBOT WITH LARGE WORKSPACE,” in *Proceedings of the ASME 2010 International Design Engineering Technical Conferences & Computers and Information in Engineering Conference*, Montreal, 2010.
- [5] “<https://www.pololu.com/product/2128>,” [Online].
- [6] “<https://www.pjrc.com/store/teensy32.html>,” [Online].
- [7] “[https://www.amazon.co.uk/gp/product/B07F342J8K/ref=ppx\\_yo\\_dt\\_b\\_asin\\_title\\_o03\\_s00?ie=UTF8&psc=1](https://www.amazon.co.uk/gp/product/B07F342J8K/ref=ppx_yo_dt_b_asin_title_o03_s00?ie=UTF8&psc=1),” [Online].
- [8] “<https://hackaday.io/project/173325-educational-five-bar-parallel-robot-double-scara>,” [Online].
- [9] L. Vathan.B, H. Kumar and B. . I. John. H, “Kinematic Analysis of Five-Bar Mechanism in Industrial Robotics”.
- [10] “<https://reprap.org/forum/read.php?185,490216>,” [Online].
- [11] S. Yanli, L. Yanli, W. Hongtao, H. Chunlong and W. Shuai , “Forward and Inverse Kinematics for a Novel Double Scara Robot,” in *2nd International Symposium on Resource Exploration and Environmental Science*, 2018.
- [12] L. Tien Dung, K. Hee-Jun and D. Quang Vinh , “A Method for Optimal Kinematic Design of Five-bar Planar Parallel Manipulators,” 2017.
- [13] “<https://uk.rs-online.com/web/p/timing-belts/7785054/>,” [Online].
- [14] “<https://luni64.github.io/TeensyStep/>,” [Online].
- [15] “<https://www.youtube.com/watch?v=c6jG3WN4W8Y>,” [Online].
- [16] “<https://www.amazon.co.uk/KATSU-Indicator-0-10mm-Magnetic-Storage/dp/B088FX6P91>,” [Online].
- [17] A. Barrientos, L. F. Peñin, C. Balaguer and R. Aracil Santoja, *Fundamentos de Robótica*, Madrid: McGraw-Hill, 2007.
- [18] “<https://www.youtube.com/watch?v=BfiHG13mHDs&feature=youtu.be>,” [Online].