

GENERAL DESCRIPTION

The AK5381 is a stereo A/D Converter with wide sampling rate of 4kHz ~ 96kHz and is suitable for High-end audio system. The AK5381 achieves high accuracy and low cost by using Enhanced dual bit $\Delta\Sigma$ techniques. The AK5381 requires no external components because the analog inputs are single-ended. The audio interface has two formats (MSB justified, I^2S) and can correspond to many systems like music instrument and AV receiver.

FEATURES

- Stereo $\Delta\Sigma$ ADC
- On-Chip Digital Anti-Alias Filtering
- Single-ended Input
- Digital HPF for DC-Offset cancel
- S/(N+D): 96dB@5V for 48kHz
- DR: 106dB@5V for 48kHz
- S/N: 106dB@5V for 48kHz
- Sampling Rate Ranging from 4kHz to 96kHz
- Master Clock:
 - 256fs/384fs/512fs/768fs (~ 48kHz)
 - 256fs/384fs (~ 96kHz)
- Audio Interface: Master or Slave Mode selectable
- Input level: TTL/CMOS selectable
- AK5381 does not support TTL level mode at fs=48kHz to 96kHz.
- Output format: 24bit MSB justified / I^2S selectable
- Power Supply: 4.5 ~ 5.5V (VA)
 - 2.7 ~ 5.5V (VD at 48kHz)
 - 3.0 ~ 5.5V (VD at 96kHz)
- Ta = -40 ~ 85°C
- Small 16pin TSSOP Package
- AK5380 Pin-compatible

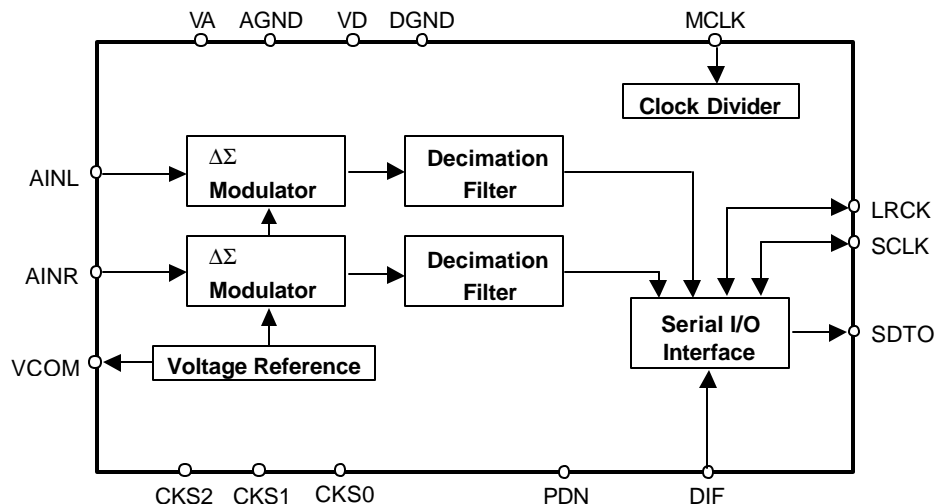

■ Ordering Guide

AK5381VT
AKD5381

-40 ~ +85°C
Evaluation Board for AK5381

16pin TSSOP (0.65mm pitch)

■ Pin Layout

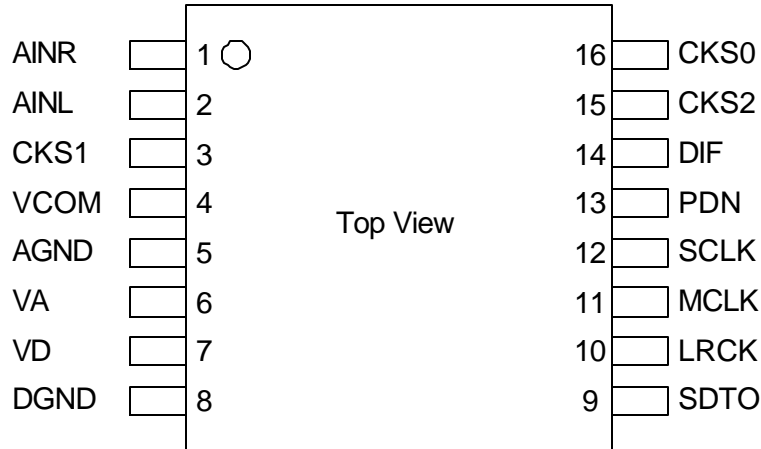

■ Compatibility with AK5380

	AK5380	AK5381
Master Mode	Not Available	Available
HPF OFF	Not Available	Available
TTL Level Mode	4kHz to 96kHz	4kHz to 48kHz
VIH@TTL Level Mode	2.2V	2.4V
VD (Digital Supply)	4.5 to 5.5V@fs=96kHz	3.0 to 5.5V@fs=96kHz
Pin #3	NC	CKS1
Pin #15	TTL	CKS2
Pin #16	TST	CKS0

PIN / FUNCTION

No.	Pin Name	I/O	Function
1	AINR	I	Rch Analog Input Pin
2	AINL	I	Lch Analog Input Pin
3	CKS1	I	Mode Select 1 Pin
4	VCOM	O	Common Voltage Output Pin, VA/2 Bias voltage of ADC input.
5	AGND	-	Analog Ground Pin
6	VA	-	Analog Power Supply Pin, 4.5 ~ 5.5V
7	VD	-	Digital Power Supply Pin, 2.7 ~ 5.5V(fs=4k ~ 48kHz), 3.0 ~ 5.5V(fs=48k ~ 96kHz)
8	DGND	-	Digital Ground Pin
9	SDTO	O	Audio Serial Data Output Pin “L” Output at Power-down mode.
10	LRCK	I/O	Output Channel Clock Pin “L” Output in Master Mode at Power-down mode.
11	MCLK	I	Master Clock Input Pin
12	SCLK	I/O	Audio Serial Data Clock Pin “L” Output in Master Mode at Power-down mode.
13	PDN	I	Power Down Mode Pin “H”: Power up, “L”: Power down
14	DIF	I	Audio Interface Format Pin “H” : 24bit I ² S Compatible, “L” : 24bit MSB justified
15	CKS2	I	Mode Select 2 Pin
16	CKS0	I	Mode Select 0 Pin

Note: All digital input pins should not be left floating.

ABSOLUTE MAXIMUM RATINGS

(AGND, DGND=0V; Note 1)

Parameter		Symbol	min	max	Units
Power Supplies:	Analog	VA	-0.3	6.0	V
	Digital	VD	-0.3	6.0	V
	$ AGND - DGND $ (Note 2)	ΔGND	-	0.3	V
Input Current, Any Pin Except Supplies		IIN	-	± 10	mA
Analog Input Voltage (AINL, AINR pins)		VINA	-0.3	VA+0.3	V
Digital Input Voltage (All digital input pins)		VIND	-0.3	VD+0.3	V
Ambient Temperature (powered applied)		Ta	-40	85	°C
Storage Temperature		Tstg	-65	150	°C

Note 1. All voltages with respect to ground.

Note 2. AGND and DGND must be connected to the same analog ground plane.

WARNING: Operation at or beyond these limits may result in permanent damage to the device.
Normal operation is not guaranteed at these extremes.

RECOMMENDED OPERATING CONDITIONS

(AGND, DGND=0V; Note 1)

Parameter		Symbol	min	typ	max	Units
Power Supplies (Note 3)	Analog	VA	4.5	5.0	5.5	V
	Digital (fs=4kHz to 48kHz)	VD	2.7	5.0	VA	V
	Digital (fs=48kHz to 96kHz)	VD	3.0	5.0	VA	V

Note 1. All voltages with respect to ground.

Note 3. The power up sequence between VA and VD is not critical.

WARNING: AKM assumes no responsibility for the usage beyond the conditions in this datasheet.

ANALOG CHARACTERISTICS

(Ta=25°C; VA=VD=5.0V; AGND=DGND=0V; fs=48kHz, 96kHz; SCLK=64fs; Signal Frequency=1kHz; 24bit Data;
Measurement frequency=20Hz ~ 20kHz at fs=48kHz, 40Hz ~ 40kHz at fs=96kHz; unless otherwise specified)

Parameter	min	typ	max	Units
ADC Analog Input Characteristics:				
Resolution			24	Bits
Input Voltage (Note 4)	2.7	3.0	3.3	Vpp
S/(N+D) (-1dBFS)	fs=48kHz	88	96	dB
	fs=96kHz	82	90	dB
DR (-60dBFS)	fs=48kHz, A-weighted	100	106	dB
	fs=96kHz	94	102	dB
S/N	fs=48kHz, A-weighted	100	106	dB
	fs=96kHz	94	102	dB
Input Resistance	fs=48kHz	10	15	kΩ
	fs=96kHz	6	9	kΩ
Interchannel Isolation	90	110		dB
Interchannel Gain Mismatch		0.1	0.5	dB
Gain Drift		100	150	ppm/°C
Power Supply Rejection (Note 5)		50	-	dB
Power Supplies				
Power Supply Current				
Normal Operation (PDN pin = "H")				
VA		16	24	mA
VD (fs=48kHz)		8	12	mA
VD (fs=96kHz)		14	21	mA
Power down mode (PDN pin = "L") (Note 6)				
VA+VD		10	100	μA

Note 4. This value is the full scale (0dB) of the input voltage. Input voltage is proportional to VA voltage.

$$V_{in} = 0.6 \times V_A \text{ (Vpp)}$$

Note 5. PSR is applied to VA and VD with 1kHz, 50mVpp.

Note 6. All digital input pins are held VD or DGND.

FILTER CHARACTERISTICS (fs=48kHz)

(Ta=-40 ~ 85°C; VA=4.5 ~ 5.5V; VD=2.7 ~ 5.5V)

Parameter	Symbol	min	typ	max	Units
ADC Digital Filter (Decimation LPF):					
Passband (Note 7)	±0.005dB	PB	0		kHz
	±0.02dB		-	21.768	kHz
	-0.06dB		-	22.0	kHz
	-6.0dB		-	24.0	kHz
Stopband	SB	26.5			kHz
Passband Ripple	PR			±0.005	dB
Stopband Attenuation	SA	80			dB
Group Delay Distortion	ΔGD		0		μs
Group Delay (Note 8)	GD		27.6		1/fs
ADC Digital Filter (HPF):					
Frequency Response (Note 7)	-3dB	FR		1.0	Hz
	-0.5dB			2.9	Hz
	-0.1dB			6.5	Hz

FILTER CHARACTERISTICS (fs=96kHz)

(Ta=-40 ~ 85°C; VA=4.5 ~ 5.5V; VD=3.0 ~ 5.5V)

Parameter	Symbol	min	typ	max	Units
ADC Digital Filter (Decimation LPF):					
Passband (Note 7)	±0.005dB	PB	0		kHz
	±0.02dB		-	43.536	kHz
	-0.06dB		-	44.0	kHz
	-6.0dB		-	48.0	kHz
Stopband	SB	53.0			kHz
Passband Ripple	PR			±0.005	dB
Stopband Attenuation	SA	80			dB
Group Delay Distortion	ΔGD		0		μs
Group Delay (Note 8)	GD		27.6		1/fs
ADC Digital Filter (HPF):					
Frequency Response (Note 7)	-3dB	FR		2.0	Hz
	-0.5dB			5.8	Hz
	-0.1dB			13.0	Hz

Note 7. The passband and stopband frequencies scale with fs. The reference frequency of these responses is 1kHz.

Note 8. The calculated delay time induced by digital filtering. This time is from the input of an analog signal to the setting of 24bit data both channels to the ADC output register for ADC.

DC CHARACTERISTICS (CMOS Level Mode)

(Ta=-40 ~ 85°C; VA=4.5 ~ 5.5V; VD=2.7 ~ 5.5V@fs=4kHz ~ 48kHz, VD=3.0 ~ 5.5V@fs=-96kHz)

Parameter	Symbol	min	typ	max	Units
High-Level Input Voltage	VIH	70%VD	-	-	V
Low-Level Input Voltage	VIL	-	-	30%VD	V
High-Level Output Voltage (Iout=-20μA)	VOH	VD-0.5	-	-	V
Low-Level Output Voltage (Iout=20μA)	VOL	-	-	0.5	V
Input Leakage Current	Iin	-	-	±10	μA

DC CHARACTERISTICS (TTL Level Mode)

(Ta=-40 ~ 85°C; VA=4.5 ~ 5.5V; VD=4.5 ~ 5.5V@fs=4kHz ~ 48kHz)

Parameter	Symbol	min	typ	max	Units
High-Level Input Voltage (CKS2-0 pins)	VIH	70%VD	-	-	V
(All pins except CKS2-0 pins)	VIH	2.4	-	-	V
Low-Level Input Voltage (CKS2-0 pins)	VIL	-	-	30%VD	V
(All pins except CKS2-0 pins)	VIL	-	-	0.8	V
High-Level Output Voltage (Iout=-100μA)	VOH	VD-0.5	-	-	V
Low-Level Output Voltage (Iout=100μA)	VOL	-	-	0.5	V
Input Leakage Current	Iin	-	-	±10	μA

SWITCHING CHARACTERISTICS (fs=4kHz ~ 48kHz)						
(Ta=-40 ~ 85°C; VA=4.5 ~ 5.5V; VD=2.7 ~ 5.5V; C _i =20pF)						
Parameter	Symbol	min	typ	max	Units	
Master Clock Timing						
Frequency	fCLK	1.024		36.864	MHz	
Pulse Width Low	tCLKL	0.4/fCLK			ns	
Pulse Width High	tCLKH	0.4/fCLK			ns	
LRCK Frequency						
	fs	4		48	kHz	
Duty Cycle		45		55	%	
	Slave mode					
	Master mode		50		%	
Audio Interface Timing						
Slave mode						
SCLK Period	tSCK	160			ns	
SCLK Pulse Width Low	tSCKL	65			ns	
Pulse Width High	tSCKH	65			ns	
LRCK Edge to SCLK “↑” (Note 9)	tLRSH	30			ns	
SCLK “↑” to LRCK Edge (Note 9)	tSHLR	30			ns	
LRCK to SDTO (MSB) (Except I ² S mode)	tLRS			35	ns	
SCLK “↓” to SDTO	tSSD			35	ns	
Master mode						
SCLK Frequency	fSCK		64fs		Hz	
SCLK Duty	dSCK		50		%	
SCLK “↓” to LRCK	tMSLR	-20		20	ns	
SCLK “↓” to SDTO	tSSD			35	ns	
Reset Timing						
PDN Pulse Width (Note 10)	tPD	150			ns	
PDN “↑” to SDTO valid at Slave Mode (Note 11)	tPDV		4132		1/fs	
PDN “↑” to SDTO valid at Master Mode (Note 11)	tPDV		4129		1/fs	

Note 9. SCLK rising edge must not occur at the same time as LRCK edge.

Note 10. The AK5381 can be reset by bringing the PDN pin = “L”.

Note 11. This cycle is the number of LRCK rising edges from the PDN pin = “H”.

SWITCHING CHARACTERISTICS (fs=48kHz ~ 96kHz)						
(Ta=-40 ~ 85°C; VA=4.5 ~ 5.5V; VD=3.0 ~ 5.5V; Ci=20pF; CMOS Level Mode only)						
Parameter	Symbol	min	typ	max	Units	
Master Clock Timing						
Frequency	fCLK	12.288		36.864	MHz	
Pulse Width Low	tCLKL	0.4/fCLK			ns	
Pulse Width High	tCLKH	0.4/fCLK			ns	
LRCK Frequency						
	fs	48		96	kHz	
Duty Cycle						
	Slave mode	45		55	%	
	Master mode		50		%	
Audio Interface Timing						
Slave mode						
SCLK Period	tSCK	160			ns	
SCLK Pulse Width Low	tSCKL	65			ns	
Pulse Width High	tSCKH	65			ns	
LRCK Edge to SCLK “↑” (Note 9)	tLRSH	30			ns	
SCLK “↑” to LRCK Edge (Note 9)	tSHLR	30			ns	
LRCK to SDTO (MSB) (Except I ² S mode)	tLRS			35	ns	
SCLK “↓” to SDTO	tSSD			35	ns	
Master mode						
SCLK Frequency	fSCK		64fs		Hz	
SCLK Duty	dSCK		50		%	
SCLK “↓” to LRCK	tMSLR	-20		20	ns	
SCLK “↓” to SDTO	tSSD			35	ns	
Reset Timing						
PDN Pulse Width (Note 10)	tPD	150			ns	
PDN “↑” to SDTO valid at Slave Mode (Note 11)	tPDV		4132		1/fs	
PDN “↑” to SDTO valid at Master Mode (Note 11)	tPDV		4129		1/fs	

Note 9. SCLK rising edge must not occur at the same time as LRCK edge.

Note 10. The AK5381 can be reset by bringing the PDN pin = “L”.

Note 11. This cycle is the number of LRCK rising edges from the PDN pin = “H”.

■ Timing Diagram

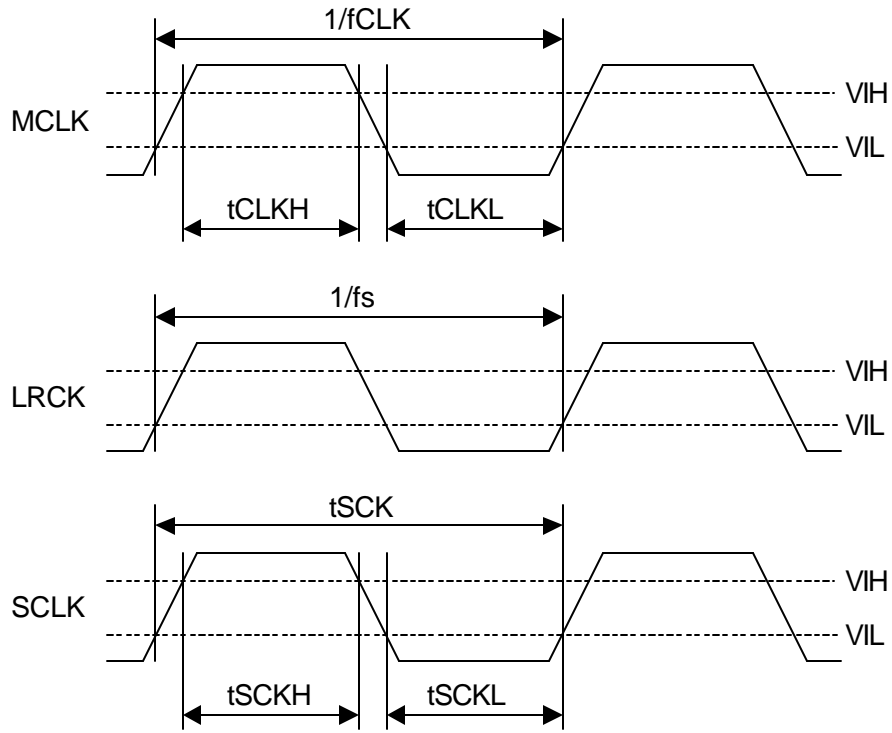

Clock Timing

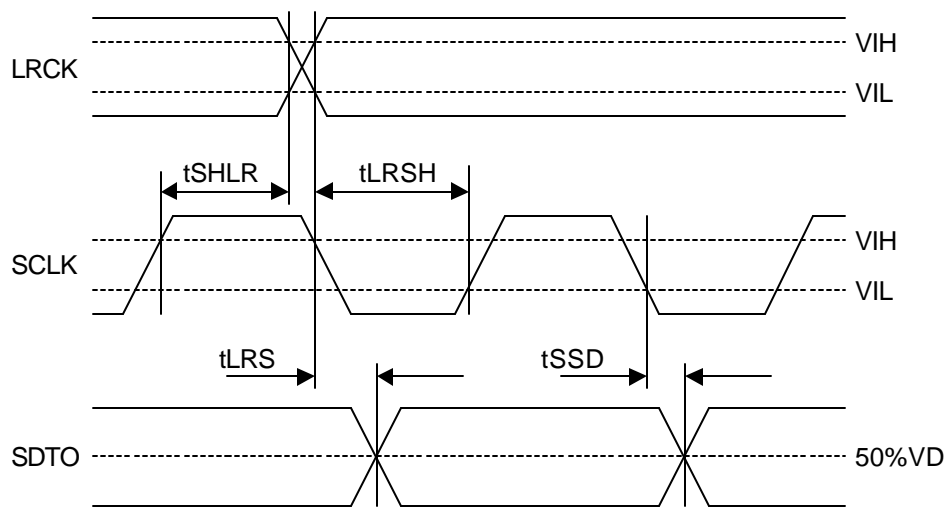

Audio Interface Timing (Slave mode)

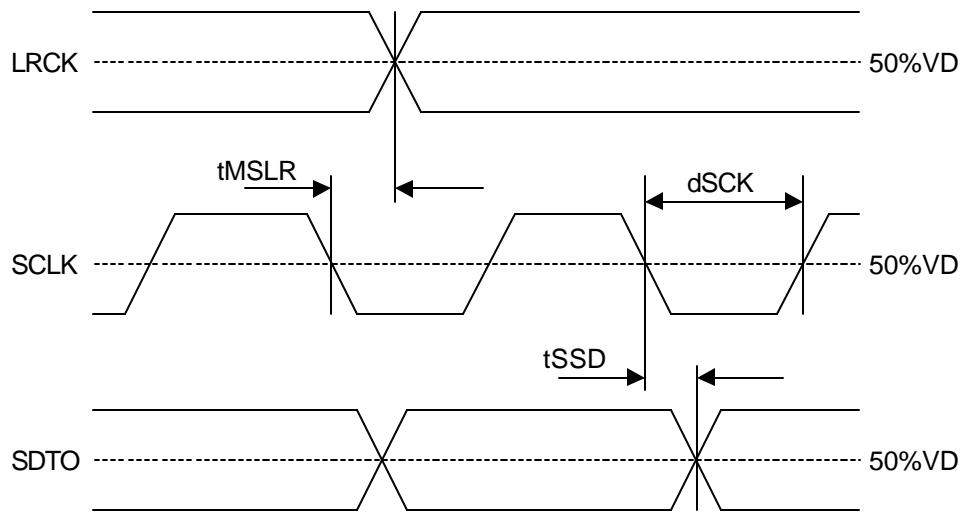

Audio Interface Timing (Master mode)

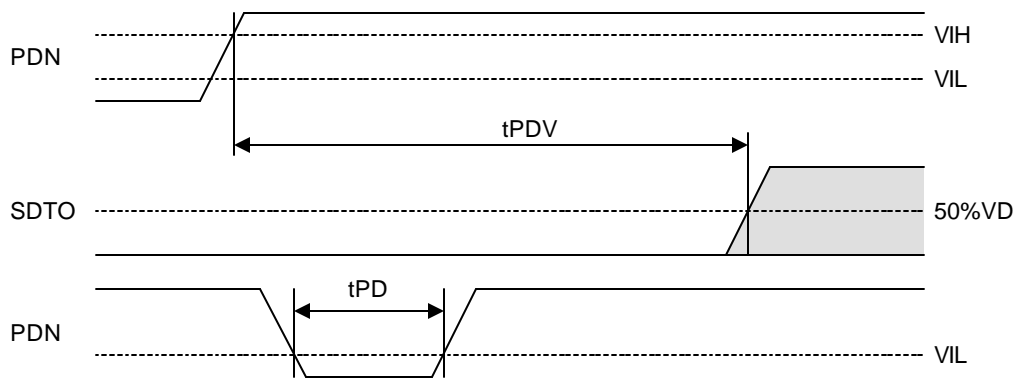

Power Down & Reset Timing

OPERATION OVERVIEW

■ System Clock

MCLK (256fs/384fs/512fs), SCLK and LRCK (fs) clocks are required in slave mode. The LRCK clock input must be synchronized with MCLK, however the phase is not critical. Table 1 shows the relationship of typical sampling frequency and the system clock frequency. MCLK frequency, SCLK frequency, HPF (ON or OFF), the input level (CMOS or TTL) and master/slave are selected by CKS2-0 pins as shown in Table 2.

All external clocks (MCLK, SCLK and LRCK) must be present unless PDN pin = “L”. If these clocks are not provided, the AK5381 may draw excess current due to its use of internal dynamically refreshed logic. If the external clocks are not present, place the AK5381 in power-down mode (PDN pin = “L”). In master mode, the master clock (MCLK) must be provided unless PDN pin = “L”.

fs	MCLK			
	256fs	384fs	512fs	768fs
32kHz	8.192MHz	12.288MHz	16.384MHz	24.576MHz
44.1kHz	11.2896MHz	16.9344MHz	22.5792MHz	33.8688MHz
48kHz	12.288MHz	18.432MHz	24.576MHz	36.864MHz
96kHz	24.576MHz	36.864MHz	N/A	N/A

Table 1. System Clock Example

CKS2	CKS1	CKS0	Input Level	HPF	Master/Slave	MCLK	SCLK	
L	L	L	CMOS	ON	Slave	256/384fs (~ 96kHz) 512/768fs (~ 48kHz)	≥ 48fs or 32fs	
L	L	H	CMOS	OFF	Slave	256/384fs (~ 96kHz) 512/768fs (~ 48kHz)	≥ 48fs or 32fs	
L	H	L	CMOS	ON	Master	256fs (~ 96kHz)	64fs	
L	H	H	CMOS	ON	Master	512fs (~ 48kHz)	64fs	
H	L	L	TTL*	ON	Slave	256fs/384/512/768fs (~ 48kHz)	≥ 48fs or 32fs	
H	L	H	Reserved					
H	H	L	CMOS	ON	Master	384fs (~ 96kHz)	64fs	
H	H	H	CMOS	ON	Master	768fs (~ 48kHz)	64fs	

Table 2. Mode Select

Note: SDTO outputs 16bit data at SCLK=32fs.

Note: The AK5381 does not support TTL interface at 96kHz.

■ Audio Interface Format

Two kinds of data formats can be chosen with the DIF pin (Table 3). In both modes, the serial data is in MSB first, 2's compliment format. The SDTO is clocked out on the falling edge of SCLK. The audio interface supports both master and slave modes. In master mode, SCLK and LRCK are output with the SCLK frequency fixed to 64fs and the LRCK frequency fixed to 1fs.

Mode	DIF pin	SDTO	LRCK	SCLK	Figure
0	L	24bit, MSB justified	H/L	≥ 48fs or 32fs	Figure 1
1	H	24bit, I ² S Compatible	L/H	≥ 48fs or 32fs	Figure 2

Table 3. Audio Interface Format

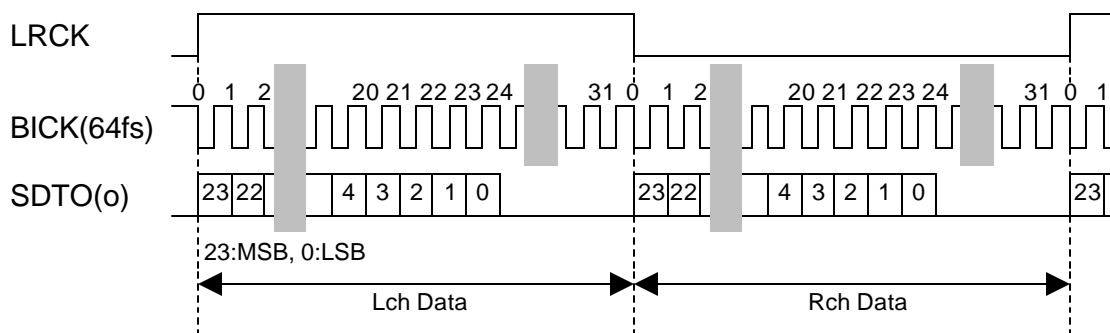

Figure 1. Mode 0 Timing

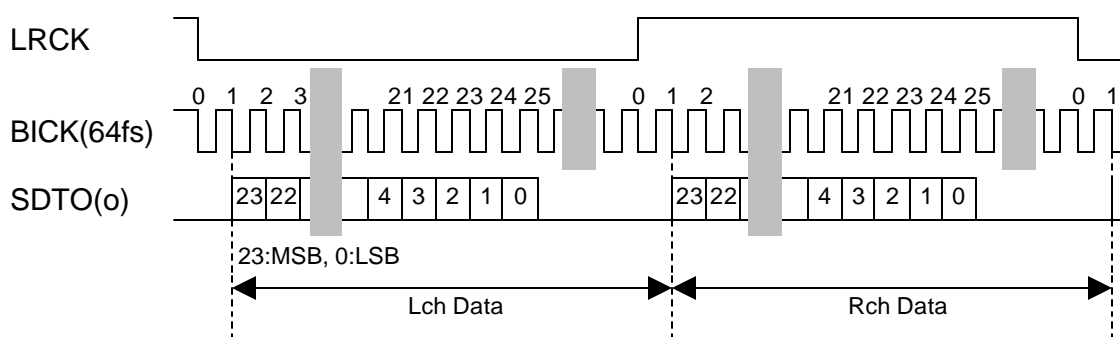

Figure 2. Mode 1 Timing

■ Digital High Pass Filter

The ADC has a digital high pass filter for DC offset cancellation. The cut-off frequency of the HPF is 1.0Hz (@fs=48kHz) and scales with sampling rate (fs).

HPF is controlled by CKS2-0 pins (Table 2). If HPF setting (ON/OFF) is changed at operating, click noise occurs by changing DC offset. It is recommended that HPF setting is changed at PDN pin = "L".

■ Power down

The AK5381 is placed in the power-down mode by bringing PDN pin “L” and the digital filter is also reset at the same time. This reset should always be done after power-up. In the power-down mode, the VCOM are AGND level. An analog initialization cycle starts after exiting the power-down mode. Therefore, the output data SDTO becomes available after 4129 cycles of LRCK clock in master mode or 4132 cycles of LRCK clock in slave mode. During initialization, the ADC digital data outputs of both channels are forced to a 2’s complement “0”. The ADC outputs settle in the data corresponding to the input signals after the end of initialization (Settling approximately takes the group delay time).

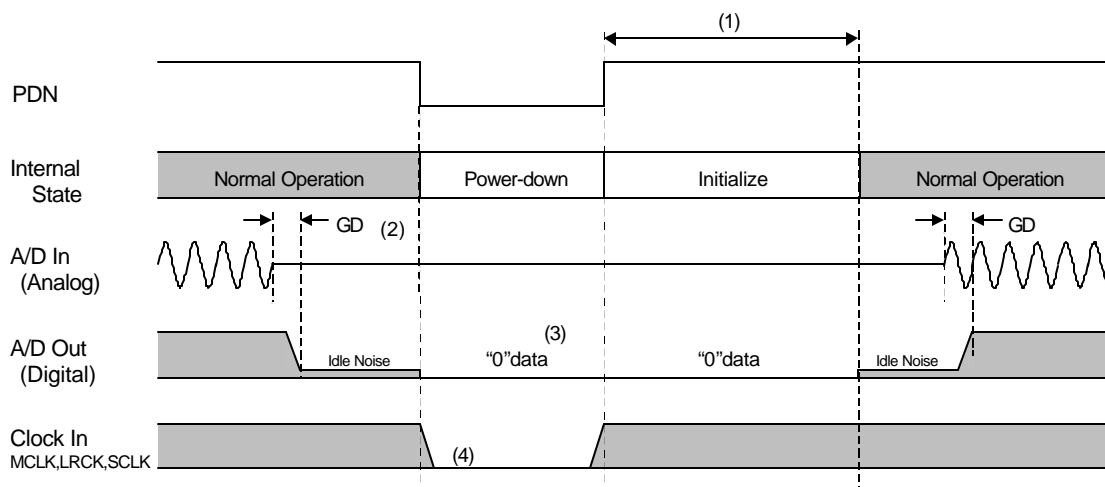

Notes:

- (1) 4132/fs in slave mode and 4129/fs in master mode.
- (2) Digital output corresponding to analog input has the group delay (GD).
- (3) A/D output is “0” data at the power-down state.
- (4) When the external clocks (MCLK, SCLK, LRCK) are stopped, the AK5381 should be in the power-down state.

Figure 3. Power-down/up sequence example

■ System Reset

The AK5381 should be reset once by bringing PDN pin “L” after power-up. The internal timing starts clocking by the rising edge (falling edge at mode1) of LRCK after exiting from reset and power down state by MCLK.

SYSTEM DESIGN

Figure 4 shows the system connection diagram. An evaluation board is available which demonstrates application circuits, the optimum layout, power supply arrangements and measurement results.

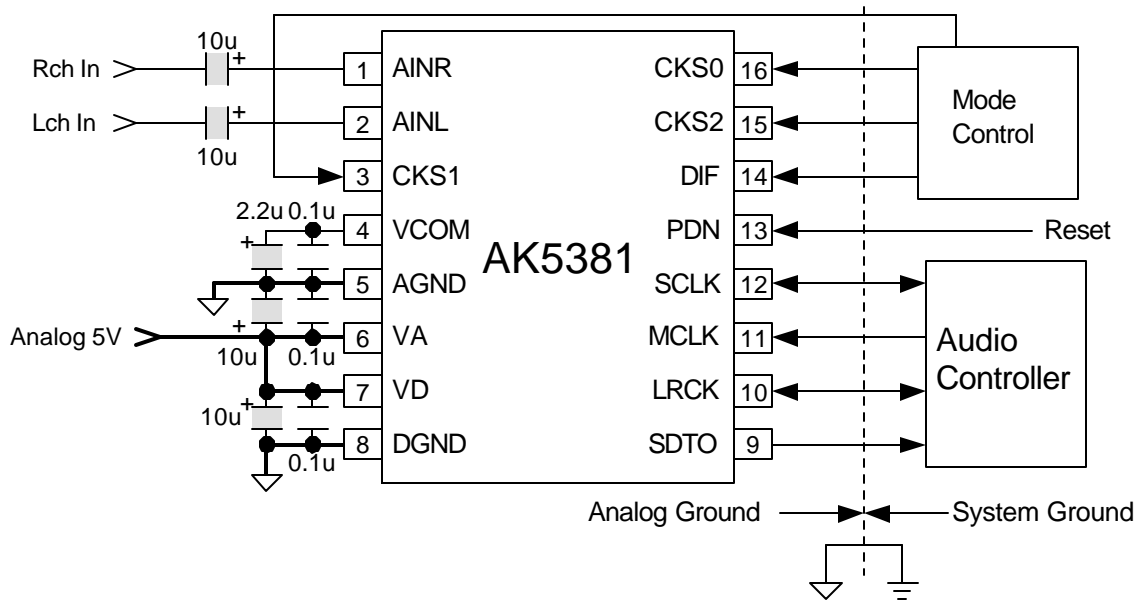

Note:

- AGND and DGND of the AK5381 should be distributed separately from the ground of external digital devices (MPU, DSP etc.).
- All input pins except pull-down pin should not be left floating.
- The CKS1 pin should be connected VA or AGND.

Figure 4. Typical Connection Diagram

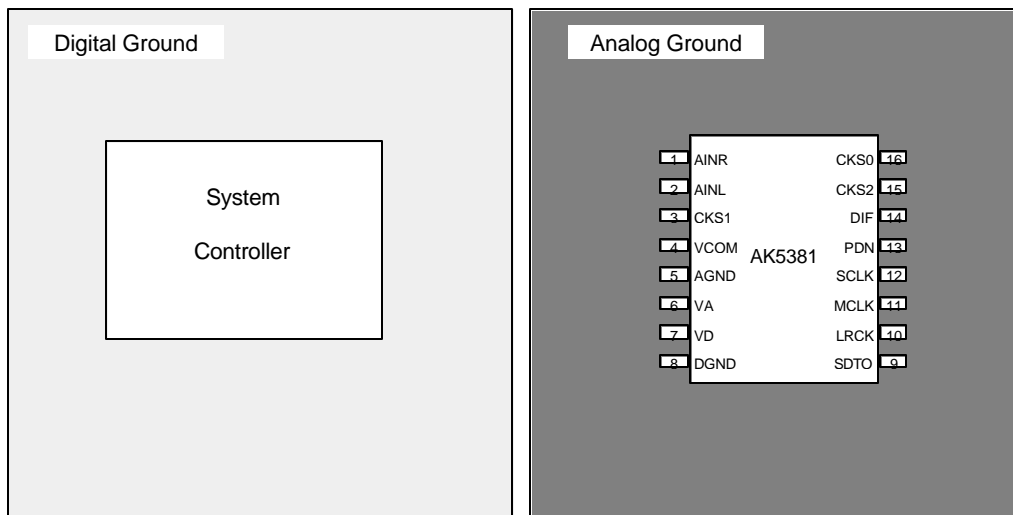

Figure 5. Ground Layout

Note:

- AGND and DGND must be connected to the same analog ground plane.

1. Grounding and Power Supply Decoupling

The AK5381 requires careful attention to power supply and grounding arrangements. VA and VD are usually supplied from the analog supply in the system. Alternatively if VA and VD are supplied separately, the power up sequence is not critical. **AGND and DGND of the AK5381 must be connected to analog ground plane.** System analog ground and digital ground should be connected together near to where the supplies are brought onto the printed circuit board. Decoupling capacitors should be as near to the AK5381 as possible, with the small value ceramic capacitor being the nearest.

2. Voltage Reference

The voltage input to VA sets the analog input range. VCOM are 50% VA and normally connected to AGND with a 0.1 μ F ceramic capacitor. An electrolytic capacitor 2.2 μ F parallel with a 0.1 μ F ceramic capacitor attached to VCOM pin eliminates the effects of high frequency noise. No load current may be drawn from these pins. All signals, especially clocks, should be kept away from the VCOM pin in order to avoid unwanted coupling into the AK5381.

3. Analog Inputs

The ADC inputs are single-ended and internally biased to the common voltage (50% VA) with 15k Ω (typ) resistance. The input signal range scales with the supply voltage and nominally 0.6xVA Vpp(typ). The ADC output data format is 2's complement. The DC offset is removed by the internal HPF.

The AK5381 samples the analog inputs at 64fs. The digital filter rejects noise above the stop band except for multiples of 64fs. The AK5381 includes an anti-aliasing filter (RC filter) to attenuate a noise around 64fs.

PACKAGE

16pin TSSOP (Unit: mm)

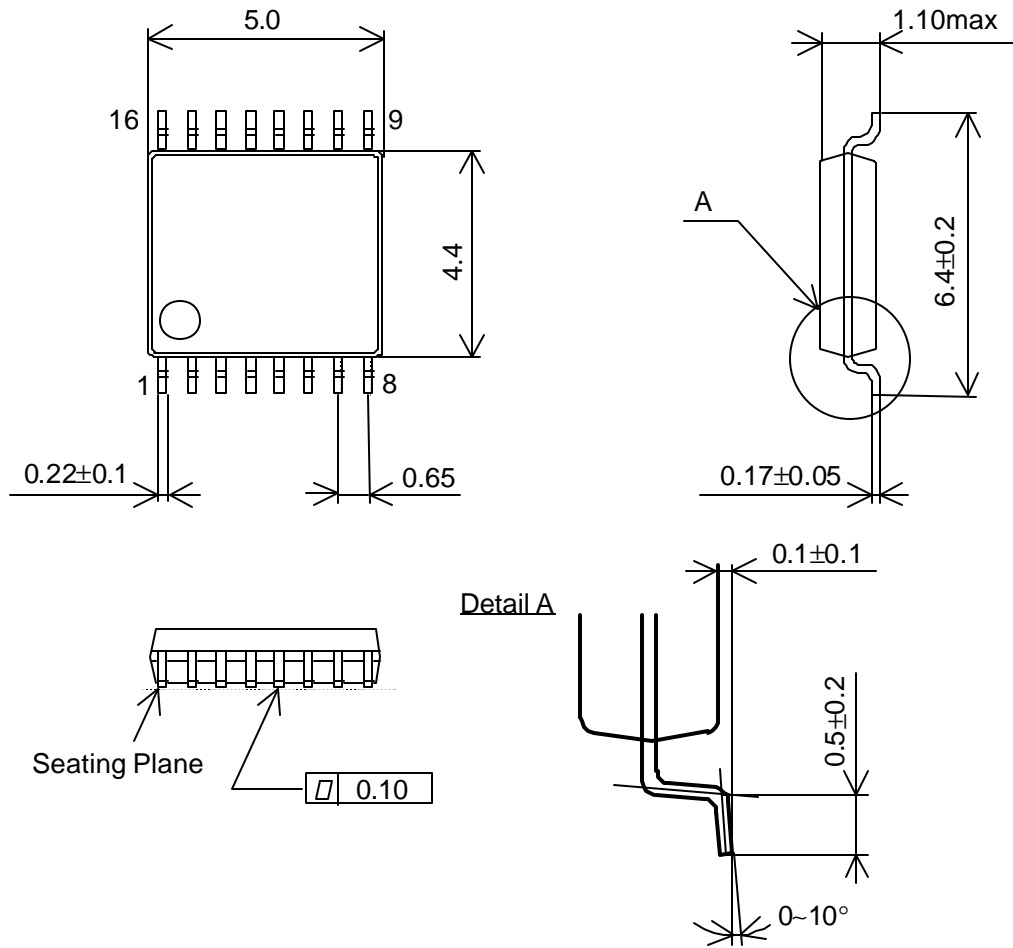

■ Material & Lead finish

Package molding compound:	Epoxy
Lead frame material:	Cu
Lead frame surface treatment:	Solder (Pb free) plate

MARKING

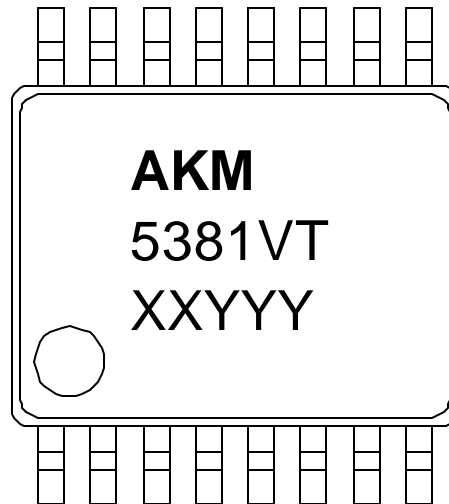

- 1) Pin #1 indication
- 2) Date Code : XXYYYY (5 digits)
 XX: Lot#
 YYY: Date Code
- 3) Marketing Code : 5381VT

IMPORTANT NOTICE

- These products and their specifications are subject to change without notice. Before considering any use or application, consult the Asahi Kasei Microsystems Co., Ltd. (AKM) sales office or authorized distributor concerning their current status.
- AKM assumes no liability for infringement of any patent, intellectual property, or other right in the application or use of any information contained herein.
- Any export of these products, or devices or systems containing them, may require an export license or other official approval under the law and regulations of the country of export pertaining to customs and tariffs, currency exchange, or strategic materials.
- AKM products are neither intended nor authorized for use as critical components in any safety, life support, or other hazard related device or system, and AKM assumes no responsibility relating to any such use, except with the express written consent of the Representative Director of AKM. As used here:
 - a. A hazard related device or system is one designed or intended for life support or maintenance of safety or for applications in medicine, aerospace, nuclear energy, or other fields, in which its failure to function or perform may reasonably be expected to result in loss of life or in significant injury or damage to person or property.
 - b. A critical component is one whose failure to function or perform may reasonably be expected to result, whether directly or indirectly, in the loss of the safety or effectiveness of the device or system containing it, and which must therefore meet very high standards of performance and reliability.
- It is the responsibility of the buyer or distributor of an AKM product who distributes, disposes of, or otherwise places the product with a third party to notify that party in advance of the above content and conditions, and the buyer or distributor agrees to assume any and all responsibility and liability for and hold AKM harmless from any and all claims arising from the use of said product in the absence of such notification.