

RTB_IMM_MUX and latch (SEL. 1)

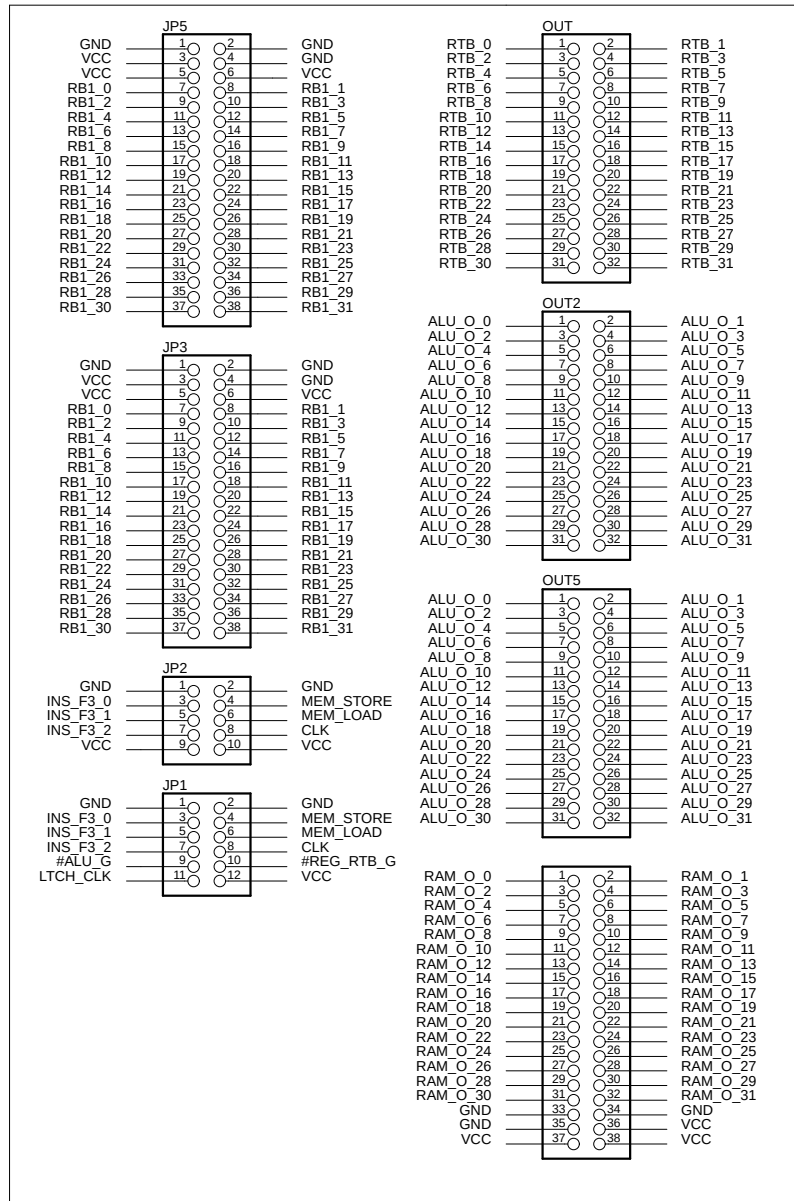

RTB_IMM_MUX and latch (SEL. 1)

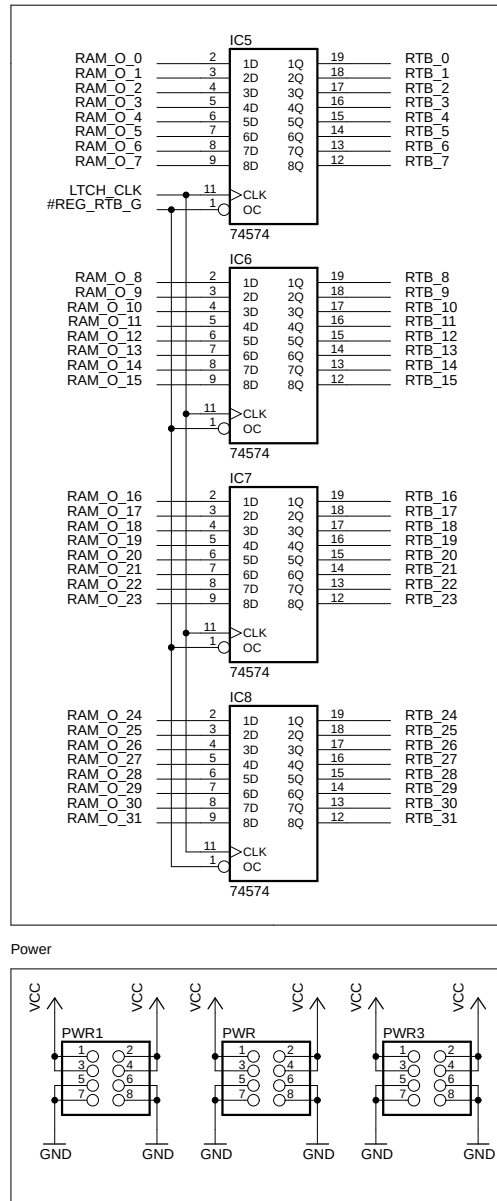

RAM Bypass

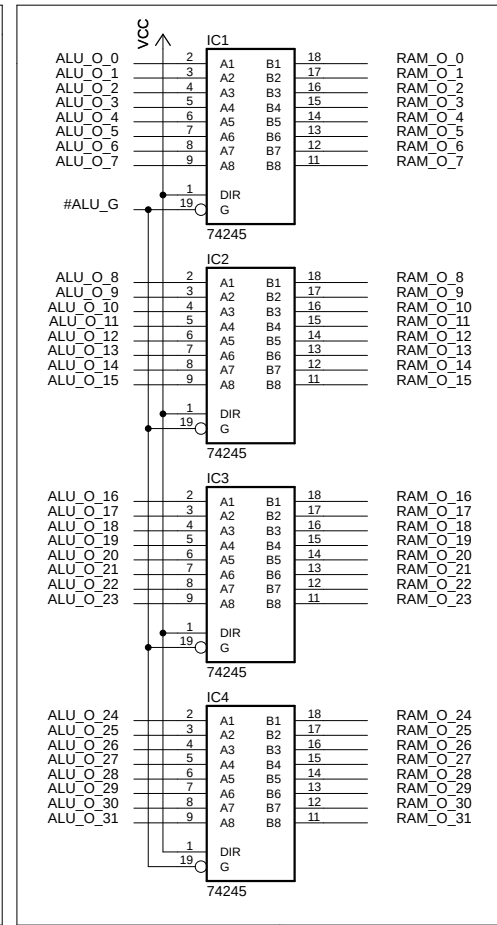

Pull-down resistors

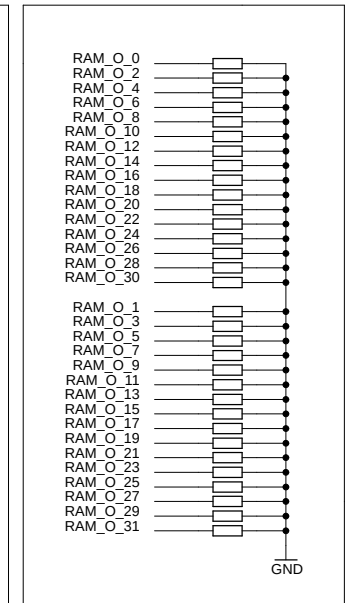

TRANSPORT
LAYER
29/10/2020

Power

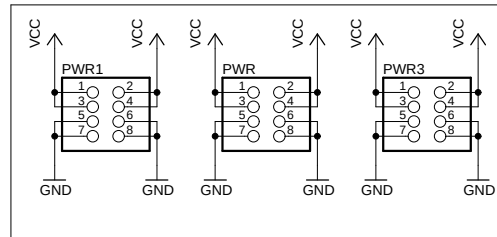

Decoupling capacitors

