

HARDWARE

Revision 4a
Nov-03-2022

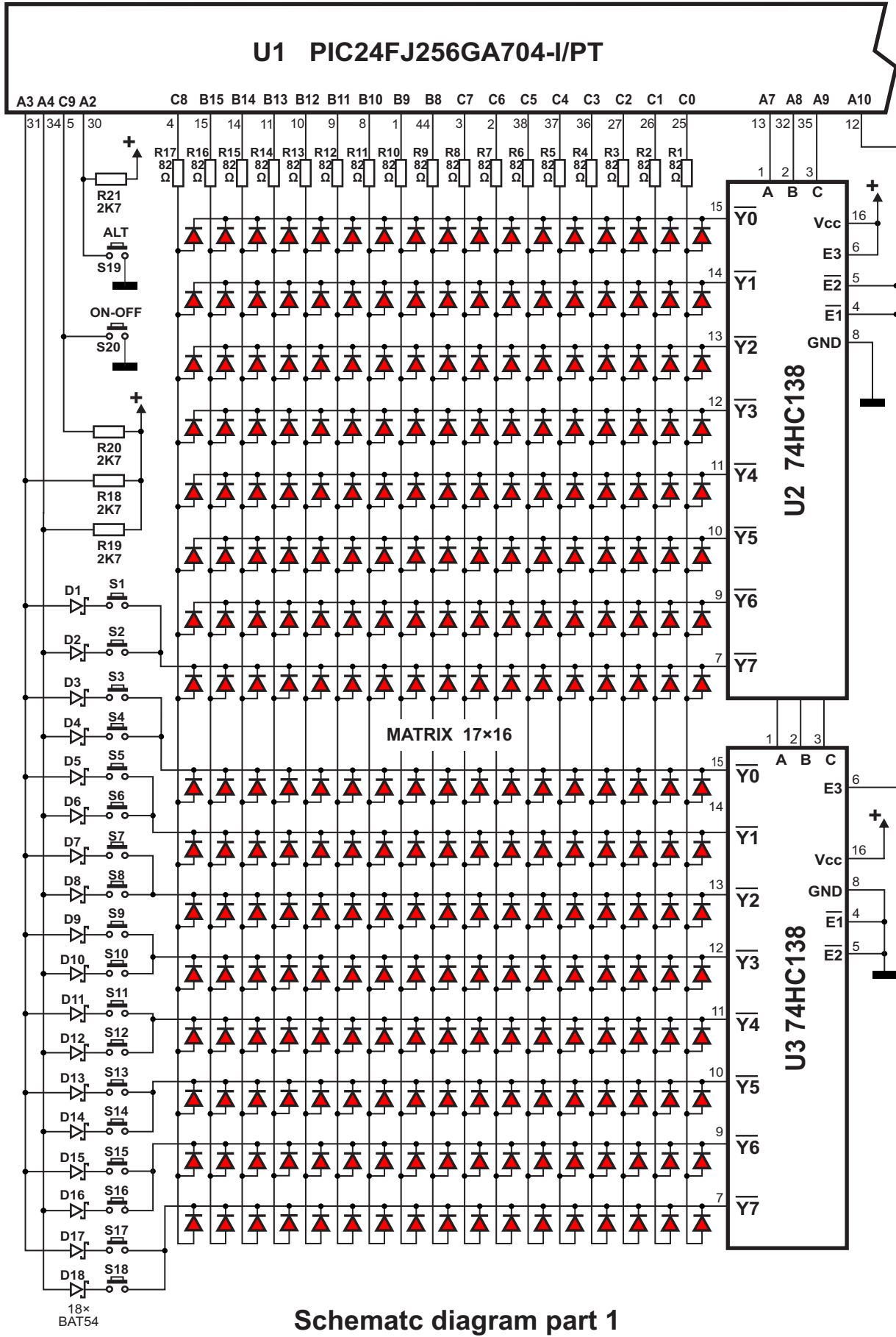

Schematc diagram part 1

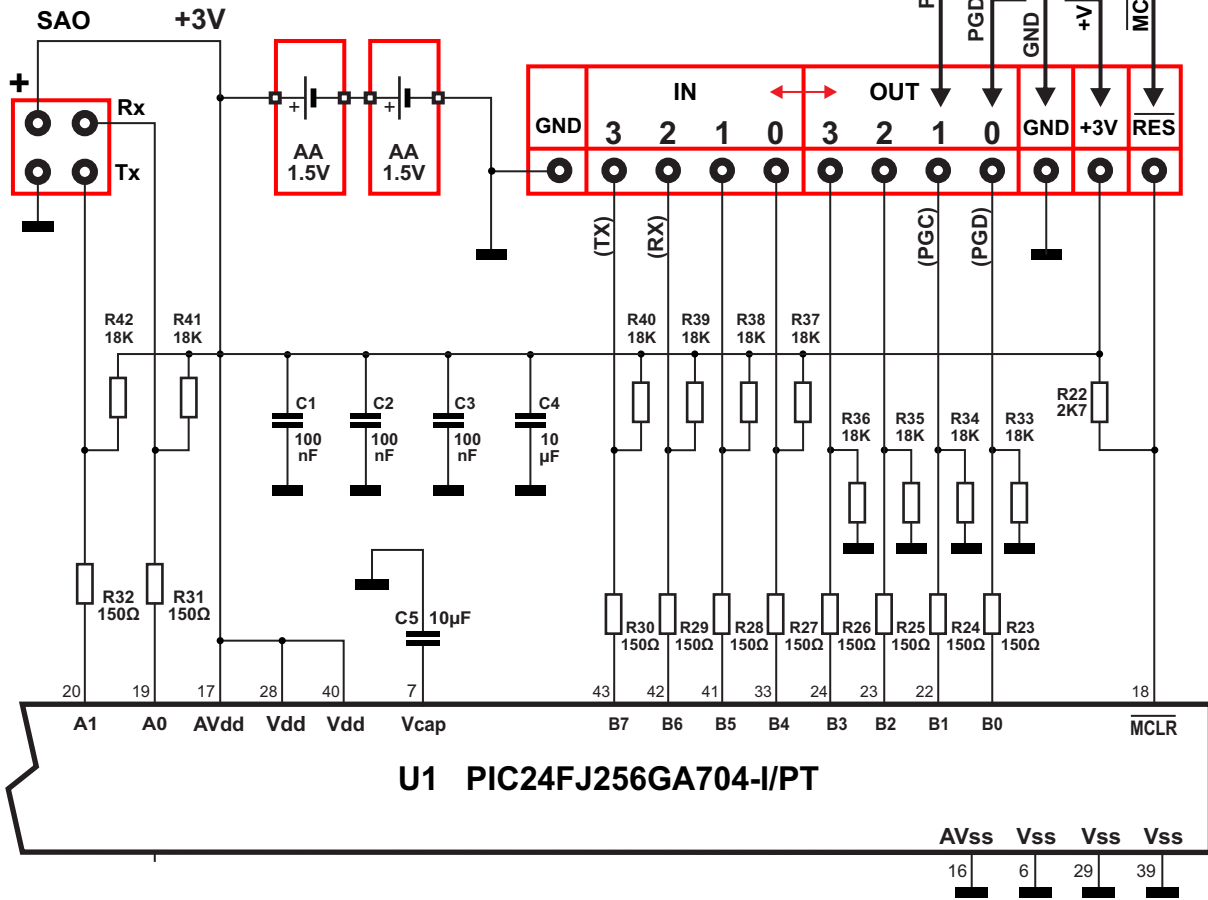

Schematic diagram part 2

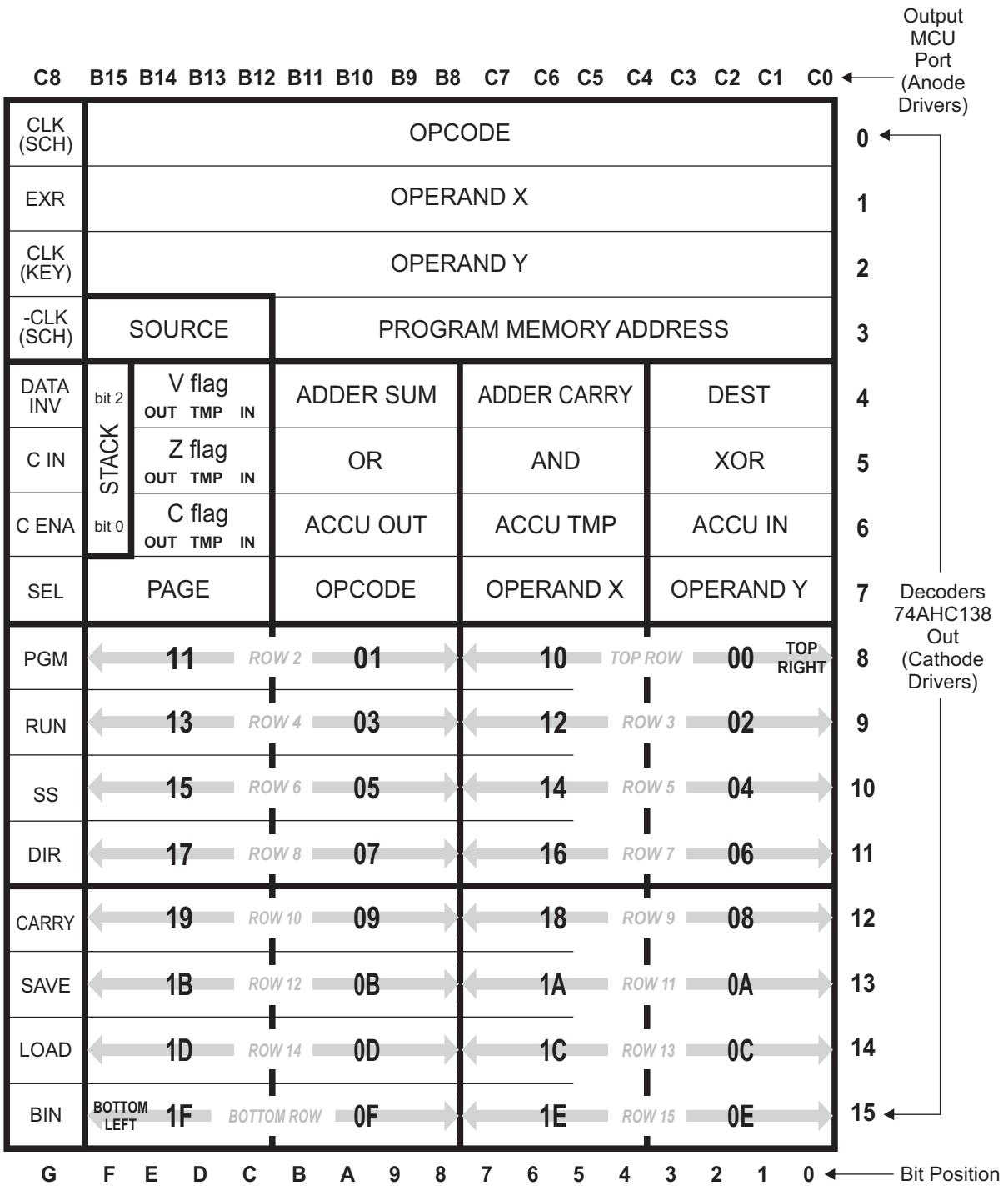

Full LED matrix 16×17
 Total 172 LEDs 0603
 182 Red LEDs
 90 Yellow LEDs

LED Matrix wiring map

ALKALINE AA BATTERY (2000 mAh) POWER SUPPLY

Parameter	Conditions	Min	Typical	Max	Alkaline Battery life AA, 2 Ah (Calculated)	
Supply Voltage	MCU User Manual data	2 V	3 V	3.6 V		
Operating Current @ 25°C (77°F) and calculated battery life	3V, Sleep Mode (OFF)		5.5µA		42 Years (**)	
	3V Dim = MAX	Number of LEDs "ON"	10	14 mA		143 h (6 days)
			40	27 mA		74 h (3 days)
			60(*)	37 mA		54 h (2 days)
			100	57 mA		35 h (1.5 days)
150			81 mA		24 h (1 day)	

(*) Average value in normal applications.

(**) This is the theoretical (calculated) battery life. The shelf life of alkaline battery is about 10 years, so it will be drained much before the calculated period.

Note: In practical tests with fresh alkaline batteries, the badge achieved operating times that were much longer than calculated. This was due to the battery voltage drop, causing the LED current to drop even more, decreasing the power consumption. The whole system worked fine down to 1.82V, but the light intensity was low.

TIMINGS

Parameter	Conditions	Min	Typical	Default	Max
IPS (Instructions Per Second) (*)	Parameters adjustable at runtime	0.5		250,000	250,000
Sync (*)		1 Hz		400 Hz	1000 Hz
Baud Rate (*)		1200		2400	115,200
Dimmer Duty Cycle (*)		6%		100%	100%
AutoOff Period (*)		After Reset or Switch ON		20 minutes	
	After any key pressed (except ON/OFF or ALT)		2.5 hours		
Timing Tolerance	0°C < T _{AMB} < +85°C 32°F < T _{AMB} < +185°F	-1.5%	0.15%		+1.5%
Flash Data Retention	V _{MAX} or T _{MAX} not violated	20 Years			

(*) These parameters are adjustable at runtime.