

## 3.3V~5V Input 24W Output Step-up DC/DC Converter

### GENERAL DESCRIPTION

The XR2981 is a high frequency, high efficiency DC to DC converter with an integrated 12A, 25mΩ power switch capable of providing an output voltage up to 24V. The fixed 600KHz allows the use of small external inductions and capacitors and provides fast transient response. It integrates Soft start, Comp., only need few components outside. It can output 6V 3.5A、9V 2A when 3.3V Battery input and output 6V 4.5A、9V 3A when 3.6V Battery input at good heat dissipation condition

### FEATURES

- 2.7V to 5.5V input voltage Range
- Efficiency up to 96%
- 24V Boost converter with 12A switch current Limit
- 600KHz fixed Switching Frequency
- Integrated soft-start
- Thermal Shutdown
- Under voltage Lockout
- Support external LDO auxiliary power supply
- 8-Pin SOP-PP Package

### APPLICATIONS

- Portable Audio Amplifier Power Supply
- Power Bank
- QC 2.0/Type C
- Wireless Charger
- POS Printer Power Supply
- Small Motor Power Supply

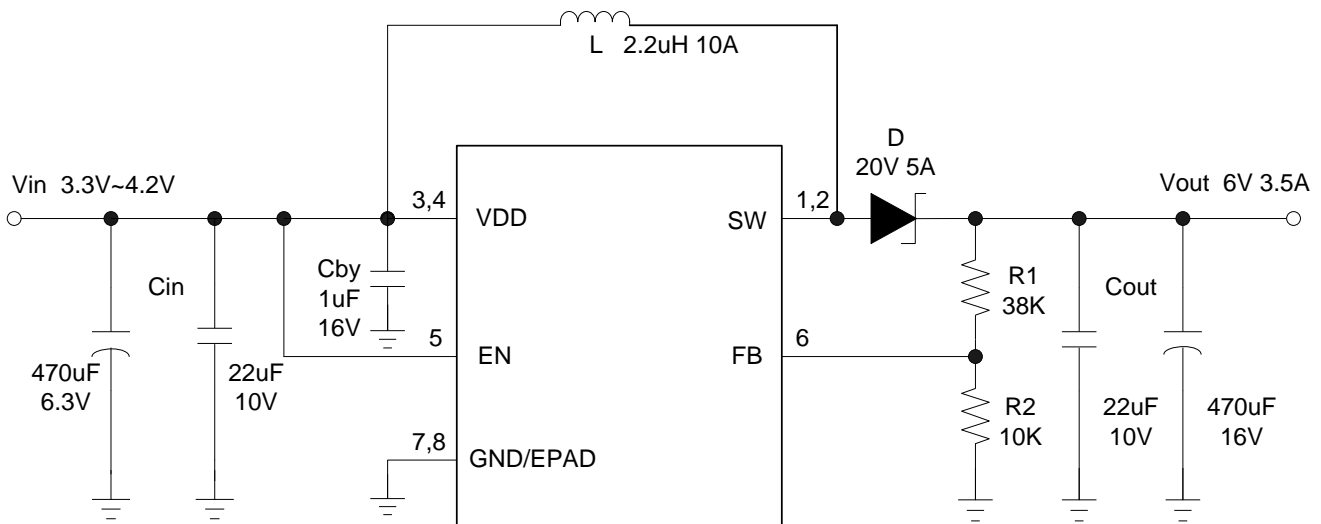
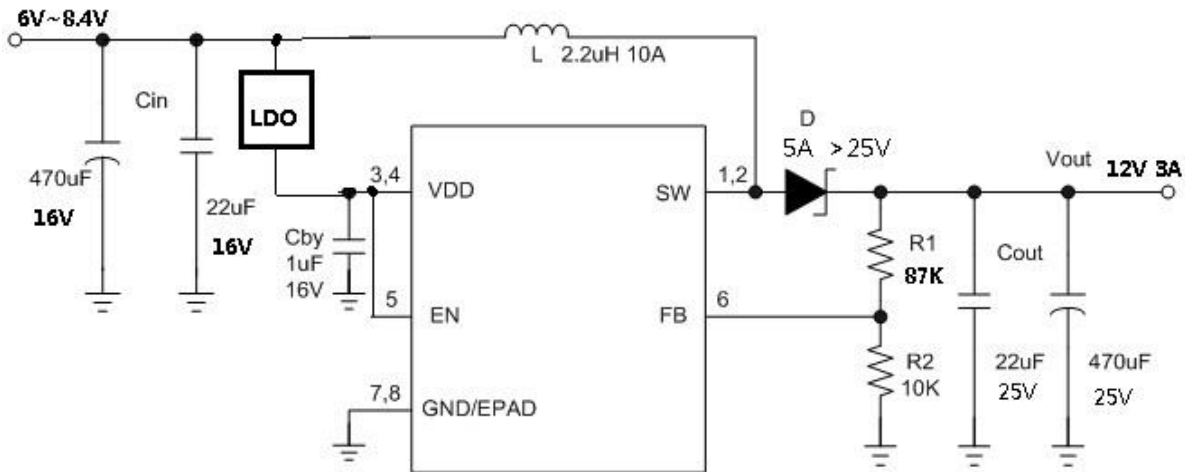

Figure 1. Typical Application Circuit1

( for Single cell Li-Battery)



**Figure 2. Typical Application Circuit2**  
**( for Dual cell Li-Battery)**

## ORDERING INFORMATION

PART NUMBER	TEMP RANGE	SWICHING FREQUENCY	OUTPUT VOLTAGE (V)	ILIM (A)	PACKAGE	PINS
XR2981	-40°C to 85°C	600KHZ	ADJ	12	SOP-PP	8

## PIN CONFIGURATION

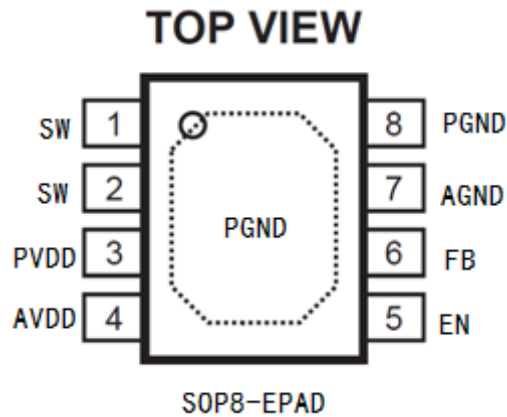

Figure 3. PIN Configuration

## PIN DESCRIPTION

PIN NUMBER	PIN NAME	PIN DESCRIPTION
1,2	SW	Switch pin
3	PVDD	Input power supply pin, please connect with Cin close asp
4	AVDD	Boost IC Logic power supply pin , if far from Cin, please add one 1uF MLCC close asp
5	EN	Shutdown control input., Connect this pin to logic high level to enable the device
6	FB	Feedback pin
7	AGND	Analog ground
8	PGND	Power ground
EPAD	PGND	Please connect with PGND & AGND by mass metal for Low Rdson , High efficiency & Good heat dissipation

## ABSOLUTE MAXIMUM RATINGS

(Note: Do not exceed these limits to prevent damage to the device. Exposure to absolute maximum rating conditions for long periods may affect device reliability.)

PARAMETER	VALUE	UNIT
Supply Voltage $V_{IN}$	-0.3 to 6.5	V
FB, EN Voltage	-0.3 to 6.5	V
SW Voltage	-0.3 to 26V	V
Operating Ambient Temperature	-40 to 85	°C
Maximum Junction Temperature	150	°C
Storage Temperature	-55 to 150	°C
Lead Temperature (Soldering, 10 sec)	300	°C

## ELECTRICAL CHARACTERISTICS

( $V_{IN} = 3.6V$ ,  $T_A = 25^\circ C$  unless otherwise specified)

PARAMETER	SYMBOL	TEST CONDITIONS	MIN	TYP	MAX	UNIT
Input Voltage Range	$V_{IN}$		2.7		5.5	V
Boost output voltage range	$V_{out}$		24			V
UVLO Low Threshold	$V_{UVLOL}$			2.6		V
UVLO High Threshold	$V_{UVLOH}$			3.2		V
Operating Supply Current	$I_{SUPPLY}$	$V_{FB} = 1.5V$ , $EN = V_{in}$ , $I_{Load} = 0$		140		$\mu A$
Shutdown Supply Current		$V_{EN} = 0V$ , $V_{IN} = 3.6V$			1	
Regulated Feedback Voltage	$V_{FB}$		1.21	1.24	1.27	V
Peak Inductor Current	$I_{PEAK}$			12		A
Oscillator Frequency	$F_{OSC}$		400	600	800	KHz
Rds(ON) of N-channel FET		$I_{SW} = 1A$		25		m $\Omega$
Enable Threshold		$V_{IN} = 2.7V$ to $5.5V$	0.3	1	1.5	V
Enable Leakage Current			-0.1		0.1	$\mu A$
SW Leakage Current		$V_{EN} = 0V$ , $V_{SW} = 0V$ or $5V$ , $V_{IN} = 5V$			1	$\mu A$

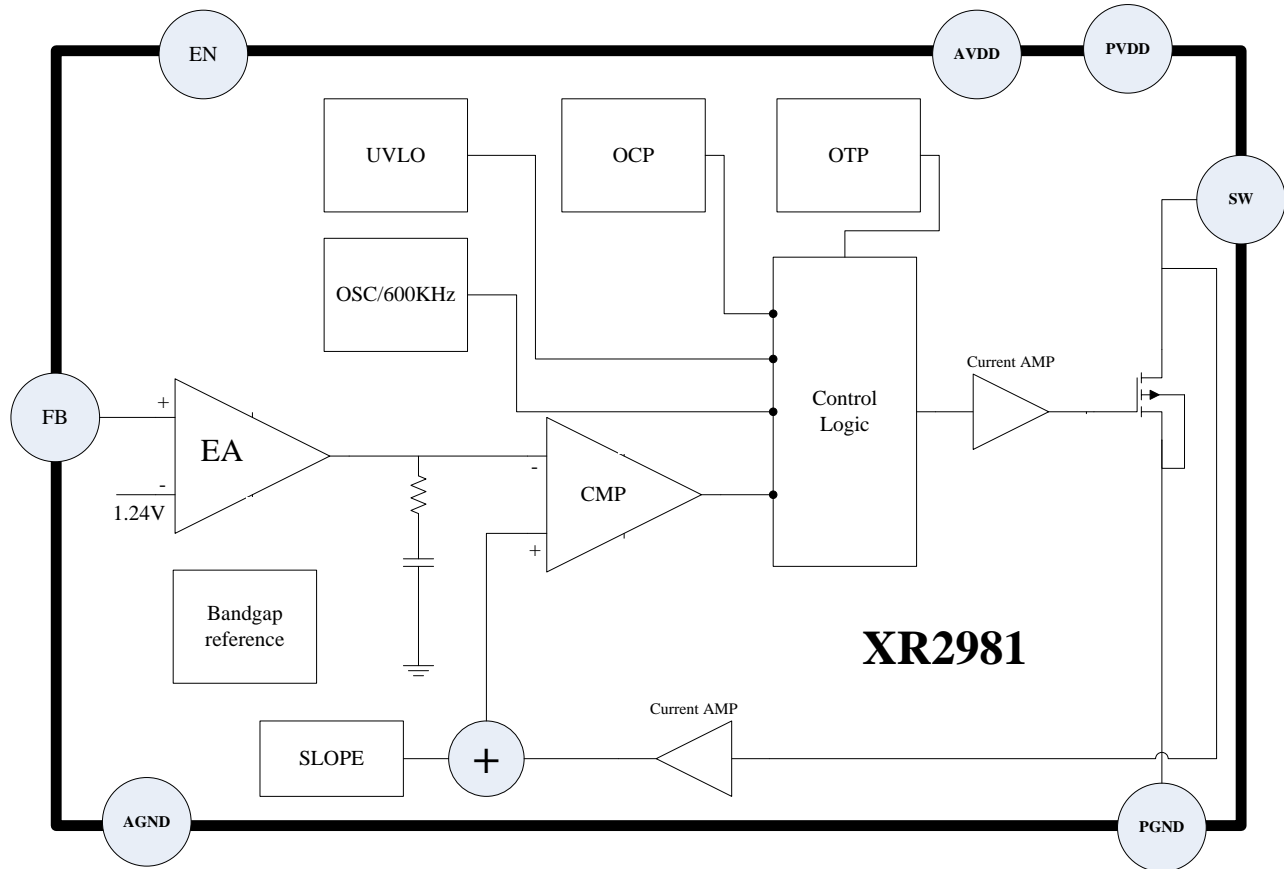

Figure 4. Functional Block Diagram

## FUNCTIONAL DESCRIPTION

### NORMAL OPERATION

The boost converter is designed for output voltage up to 24V with a 12A/24V power MOSFET. The low  $R_{ds(on)}$  of the internal power switches enables better power efficiency. The chip, which operates in a current mode scheme with constant frequency 600KHz. It operates with Pulse With Modulation(PWM). To avoid the inrush current during power up, soft start circuit is integrated in the chip.

The controller circuit of the device is based on a fixed frequency multiple feedback controller topology. Input voltage, output voltage, and voltage drop on the NMOS switch are monitored and feedback to the regulator. So changes in the operating conditions of the converter directly affect the duty cycle and must not take the indirect and slow way through the control loop and the error amplifier. The control loop, determined by the error amplifier, only has to handle small signal errors.

The input for it is the feedback voltage on the FB pin, the voltage on the internal resistor divider. It is compared with the internal reference voltage to generate an accurate and stable output voltage.

### CYCLE BY CYCLE CURRENT LIMIT

The peak current of the NMOS switch is also sensed to limit the maximum current flowing through the switch and the inductor. The typical peak current limit is set to exceed 12A.

### UNDERVOLTAGE LOCKOUT (UVLO)

Under voltage lockout prevents operation of the device at input voltages below typical 2.6V when the input voltage is falling. When the input voltage is below the under voltage threshold, the device is shut down and the internal switch FETs are turned off. If the input voltage rises by under voltage lockout hysteresis(3.2V), the IC restarts.

## THERMAL SHUTDOWN

A thermal shutdown is implemented to prevent damages due to excessive heat and power dissipation. Typically the thermal shutdown

threshold is 150°C .When the thermal shutdown is triggered the device stops switching until the temperature falls below typically 136°C.Then the device starts switching again.

## APPLICATION INFORMATION

### INDUCTOR SELECTION

In normal operation, the inductor maintains continuous current to the output. The inductor current has a ripple that is dependent on the inductance value. The high inductance reduces the ripple current.

Selected inductor by actual application:

Manufacturer	Part Number	Inductance (uH)	DRC max (mOhms)	Dimensions L*W*H(mm3)	Id	Isat
WURTH	74439358022	2.2	3.7	8.8*8.3*7.8	13A	30A
	74437368022	2.2	6.5	11*10*3.8	10A	28A
	7443330220	2.2	4.6	10.9*10*9.3	16.5A	22A
	74437349022	2.2	11.2	7.3*6.6*4.8	7.5A	14A
	744311220	2.2	11.4	6.9*7.0*3.8	9A	13A
TDK	SPM6530T	2.2	17	7.1*6.5*3	8.4A	
	VLP6045	2.2	20	6*6*4.5	6.4A	

Table 1. Recommend Surface Mount Inductors

Notes : Please select inductor according to I<sub>in</sub>. The IL need to be 1.5~2\*I<sub>in</sub>. For getting higher efficiency, need to use low DRC inductors.

### INPUT CAPACITOR SELECTION

The input capacitor reduces input voltage ripple to the converter, low ESR ceramic capacitor is highly recommended. For audio amplifier applications, A 22uF ceramic capacitor & 470uF E-cap is needed. low ESR tantalum capacitor is recommended for good ripple performance & dynamic response , The input capacitor should be placed as close as possible to VIN and GND.

### OUTPUT CAPACITOR SELECTION

A low ESR output capacitor is required in order to maintain low output voltage ripple. In the case of ceramic output capacitors, capacitor ESR is very small and does not contribute to the ripple, so a lower capacitance value is acceptable when ceramic capacitors are used. For audio amplifier applications, A 22uF ceramic capacitor & 470uF E-cap is needed. low ESR tantalum capacitor is recommended for good ripple performance & dynamic response .

---

## OUTPUT VOLTAGE PROGRAMMING

In the adjustable version, the output voltage is set by a resistive divider according to the following equation:

$$R_1 = R_2 \times \left( \frac{V_{OUT}}{1.24} - 1 \right)$$

Typically choose R2=10K and determine R1 from the following equation:

## DIODE SELECTION

According to max Iout and max Vout, you can select suitable diode. Normally we select diode If=(1.5~2)\*Ioutmax and VR=(1.5~2)\*Voutmax. For high efficiency, suggest that you select low Vf Schottky diode.

For example, 3.3V~4.2Vin 6V 3.5Aout, you can select SS12P31.

For common application, you can select SS34, SS54 according to Ioutmax

## LDO SELECTION

For Typical Application Circuit2, you need to select LDO--Input voltage range 4V~15V(or higher). Iout>=100mA. Output voltage is preferred to set 4.2V~4.5V.

LDO need enough input & output capacity, please select suitable external parts and layout them according to LDO's datasheet.

## LAYOUT CONSIDERATIONS

- 1 : The input capacitor, output capacitor, and the inductor should be placed as close as possible to the IC. to keep resistance very low and the switching loop very small for EMI performance
- 2 : The FB pin connection should be made as close to the load as possible so that the voltage at the load is the expected regulated value. and place FB network far from Switching node.
- 3 : Please make sure that the big current circuits are board and short to reduce the circuit  $R_{dson}$  , All ground connection must be tied together. Use a broad ground plane to establish the lowest resistance possible between all connections to achieve the best thermal and noise performance.
- 4: The switch node connection should be low resistance to reduce power losses.
- 5:The heavy copper board in big current output is recommended for high efficiency & good heat dissipation.

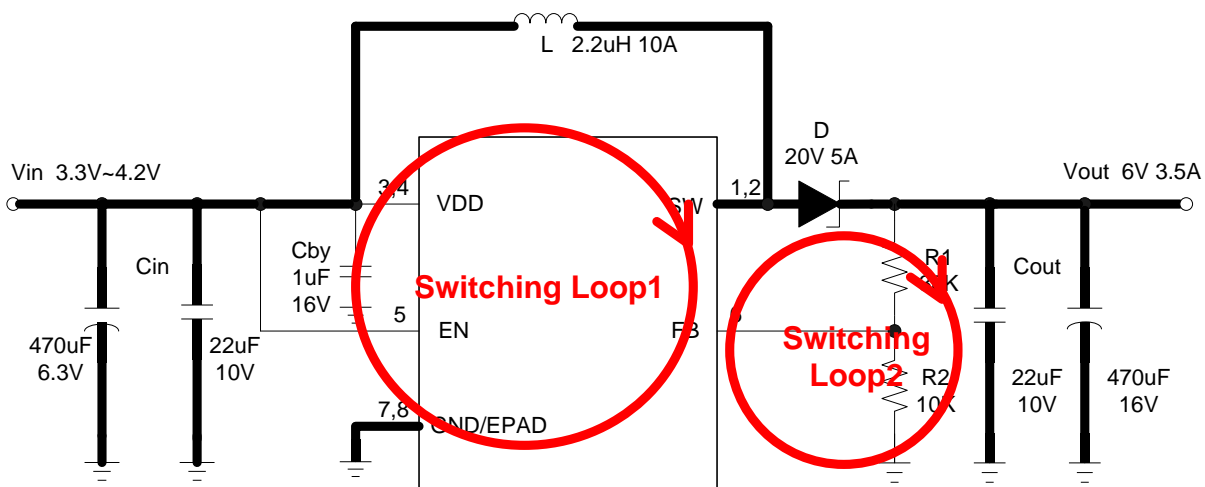

## PCB LAYOUT GUIDE

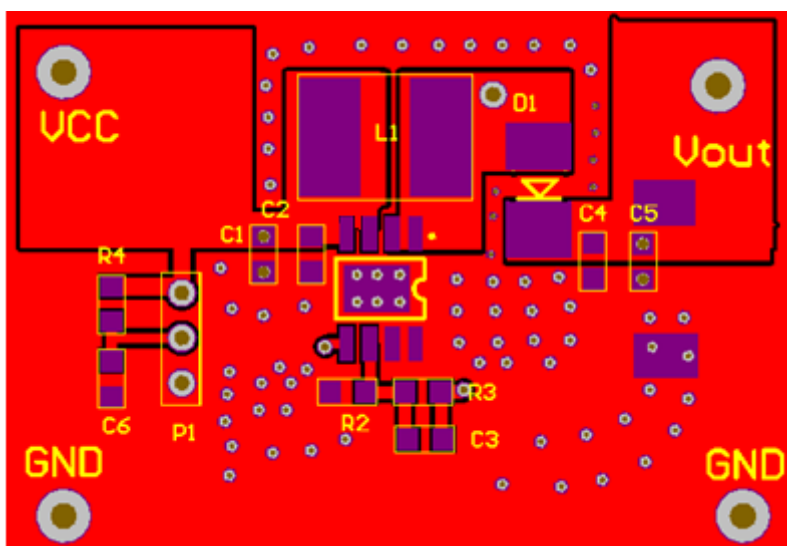

TOP LAYER

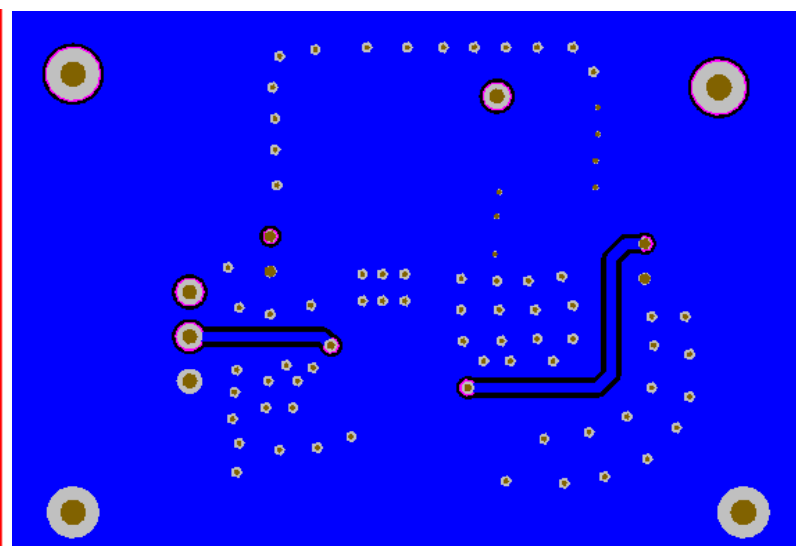

BOTTOM LAYER



## TYPICAL PERFORMANCE CHARACTERISTICS

(L=2.2uH-Wurth, Cin or Cout=22uF MLCC+470uF Ecap; D=SS12P31, if not mentioned)

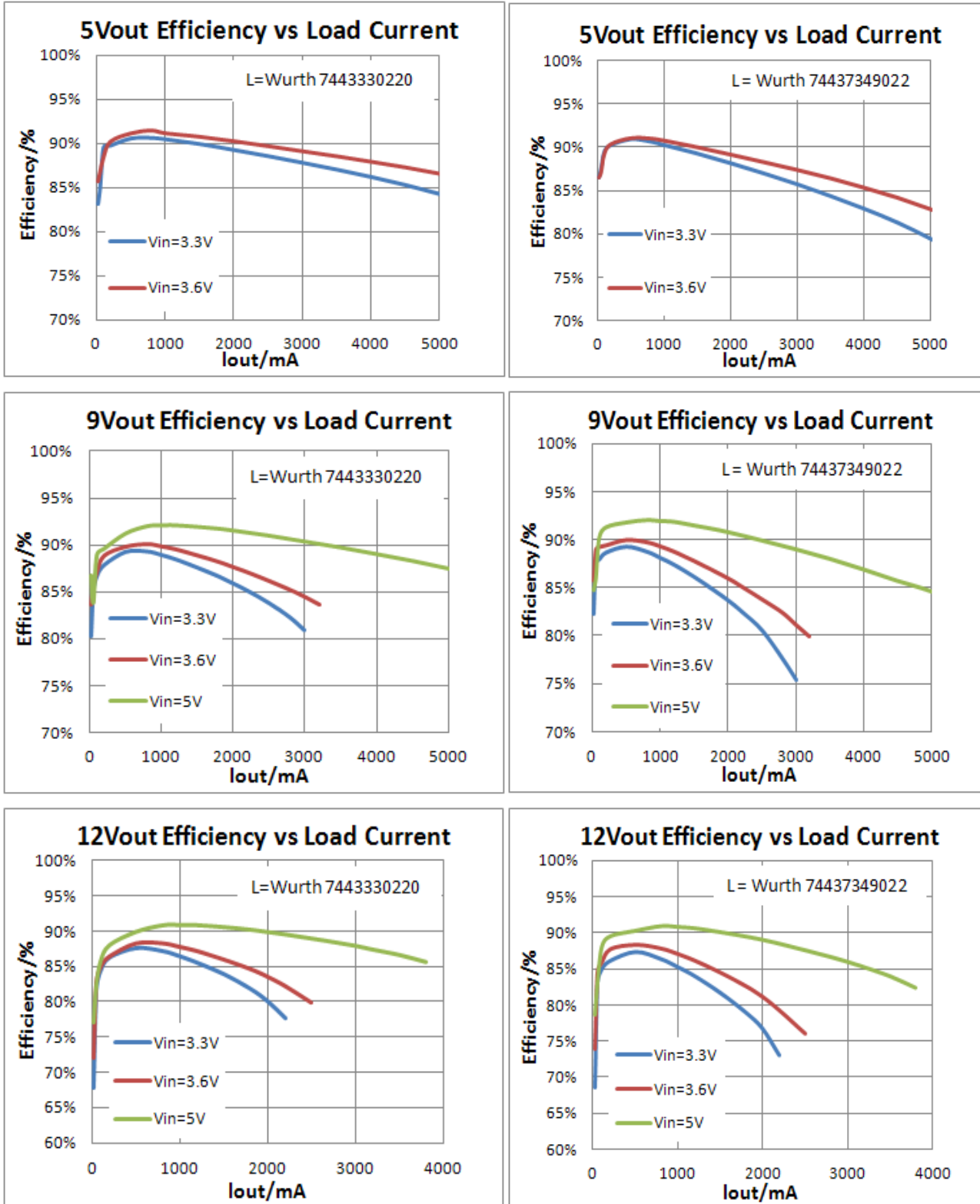

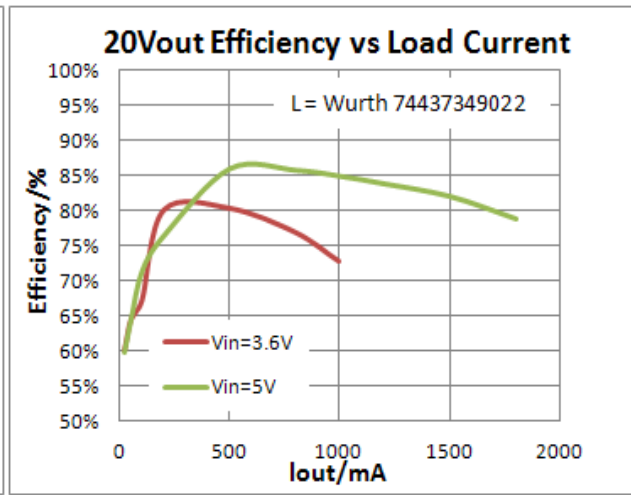
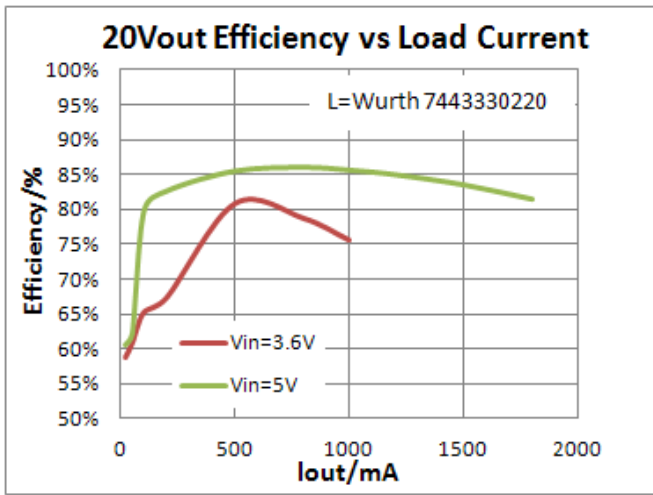

**Note:** Efficiency data is based on demo test at 20°C. If work at big current for long time, maybe thermal shutdown. its load capacity is related with heat dissipation conditions.

**3.6Vin9Vout 50mA Switching**

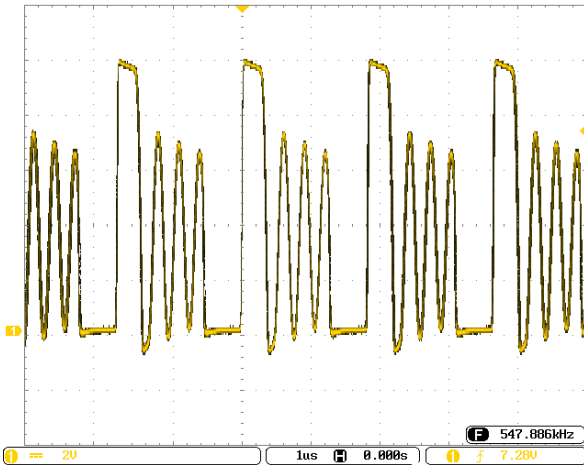

**3.6Vin9Vout 1A Switching**

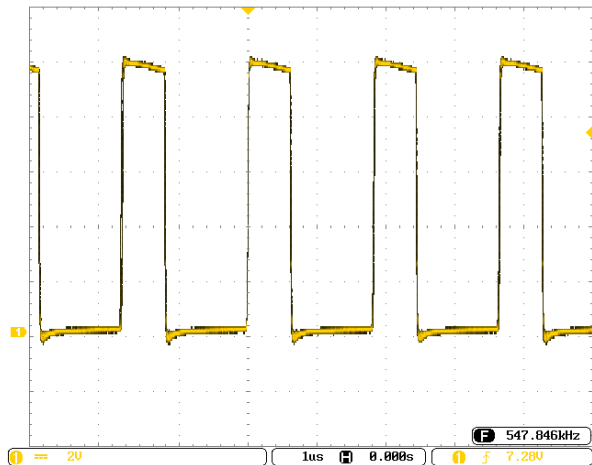

**3.6Vin12Vout 50mA Switching**

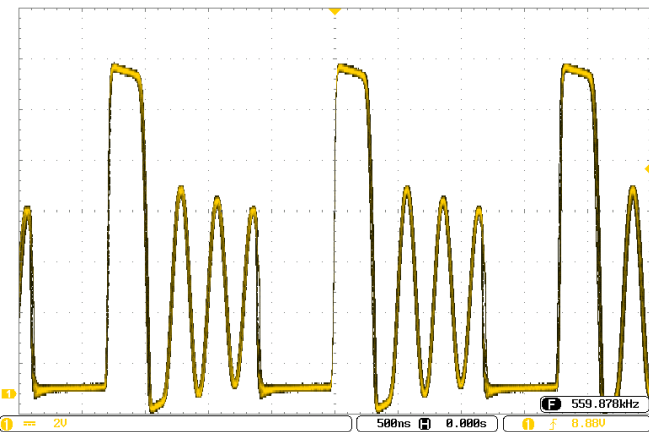

**3.6Vin12Vout 200mA Switching**

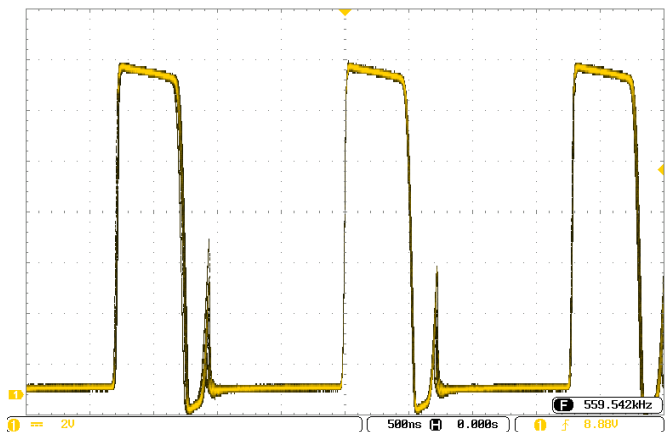

**3.6Vin12Vout 1A Switching**

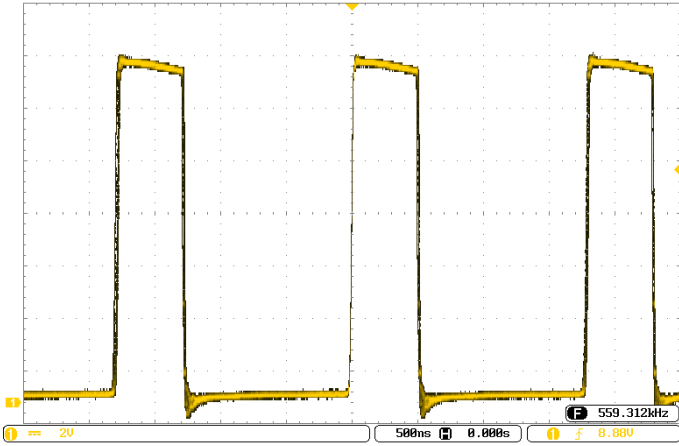

### 9Vout Startup from Vin

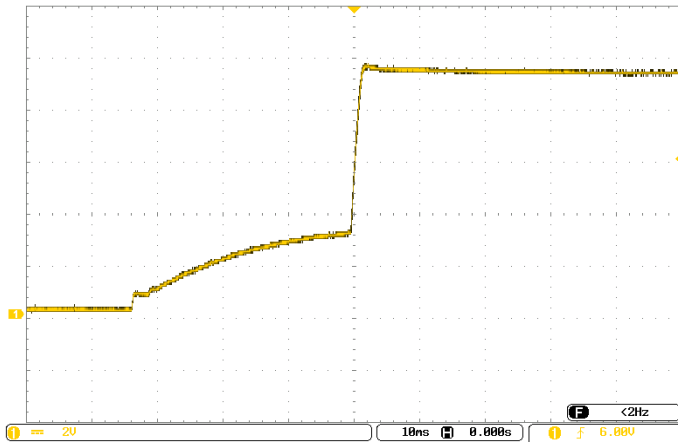

### 9Vout Startup from EN

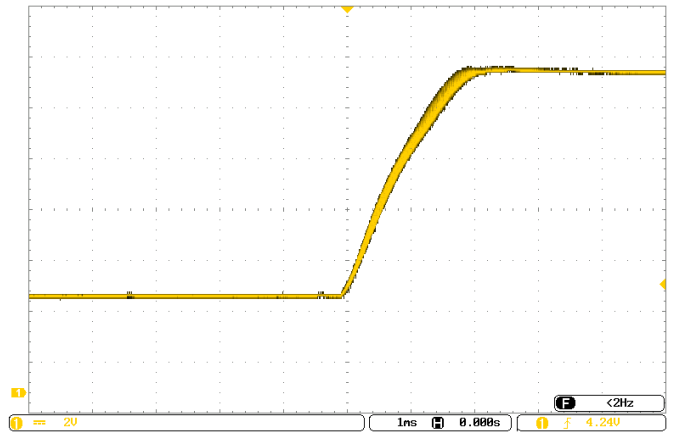

## PACKAGE OUTLINE

### SOP8-PP PACKAGE OUTLINE AND DIMENSIONS

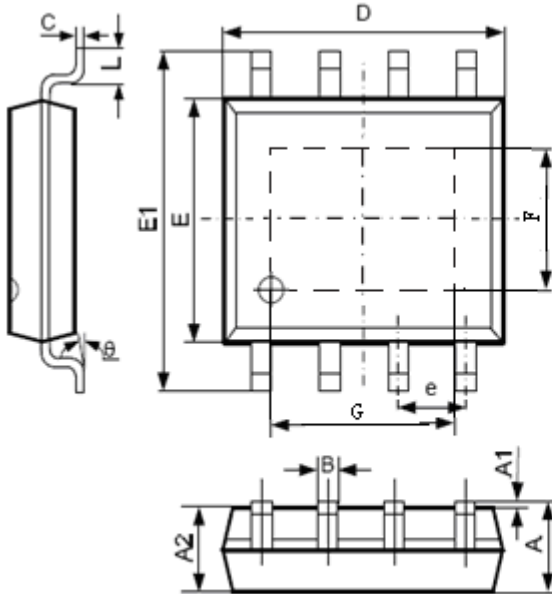

SYMBOL	Dimension in Millimeters		Dimension in Inches	
	MIN	MAX	MIN	MAX
A	1.35	1.75	0.053	0.069
A1	0.100	0.250	0.004	0.010
A2	1.350	1.550	0.053	0.061
B	0.330	0.510	0.013	0.020
C	0.190	0.250	0.007	0.010
D	4.700	5.100	0.185	0.201
E	3.800	4.000	0.150	0.157
E1	5.800	6.300	0.228	0.248
e	1.27 TYP		0.050 TYP	
L	0.400	1.270	0.016	0.050
$\theta$	0°	8°	0°	8°
F	2.26	2.56	0.089	0.101
G	3.15	3.45	0.124	0.136

In order to increase the driver current capability of XR2981 and improve the temperature of package, Please ensure Epad and enough ground PCB to release energy.

