

- ✓ **High Reliability**
- ✓ **High Performance**
- ✓ **Unbeatable Value**



Universal Input

QuiQ is designed with a wide input voltage range from 85 - 265 VAC, making it an ideal choice for any worldwide application. Power Factor Correction and 12A maximum current draw ensures the charger will work reliably from any power outlet in the world, even through surges and sags.

Standardizing on a single universal model reduces component count, saving vehicle OEMs manufacturing and service inventory management costs.

Reduced Operating Costs

The high-efficiency design and near unity Power Factor combine to make the QuiQ charger extremely grid-friendly. Over 88% of power taken from the grid is converted to real power to charge the battery. This saves users in raw electricity costs when compared to ferro-resonant chargers.

Simple Offboard Operation

Configured with standard connectors or an OEM specific DC output cord, the QuiQ can easily be used to (off board) charge almost any vehicle.

Approved Charge Algorithms

The QuiQ's intelligent microprocessor controller can store up to 10 Delta-Q-developed optimized charge algorithms. Delta-Q has designed algorithms for many types of batteries, and is constantly preparing algorithms for new battery types, sizes and chemistries. Delta-Q configures chargers with the most appropriate set of algorithms for each OEM's applications. Manufacturing and field service personnel can easily toggle between algorithms and, with new field reprogrammable chargers, download new algorithms into the charger "on the fly."

Regulatory Compliance

All Delta-Q chargers are UL and CE compliant and have passed stringent EMI, safety, vibration, and water ingress protection (IP) tests. QuiQ offers leading edge efficiency, power factor correction and GFCI compatibility for safe and reliable operation.

Designed for Onboard Use

QuiQ is built for onboard operation in harsh environments. Its rugged, lightweight and intelligent design provides continuous operation in any application. High efficiency power conversion allows the QuiQ to be delivered in a fully sealed enclosure, making it ideal for onboard applications in the dirtiest and wettest environments.

For more information contact:

Delta-Q Technologies Corp.
3755 Willingdon Avenue
Burnaby, BC V5G 3H3
Canada

tel: 604.327.8244
fax: 604.327.8246
email: info@delta-q.com
www.delta-q.com





HF/PFC Battery Chargers

Electric Vehicle Battery Charger



- Advanced high frequency design with > 90% efficiency and >.99 power factor
- Wide range AC input (85 - 265 VAC) for worldwide operation
- Fully sealed enclosure provides improved reliability in demanding environments
- Approved battery charge algorithms for ideal charging
- Integrated Charge Tracking for Advanced Troubleshooting and Charge History Analysis

QuiQ HF/PFC Battery Charger Specifications

subject to change without notice

DC Output	QuiQ Model: 912- or 913-					
	24xx	36xx	48xx	72xx	84xx	96xx
DC Output Voltage - nominal	24 V	36 V	48 V	72 V	84 V	96 V
DC Output Voltage - maximum	34 V	51 V	68 V	100 V	120 V	135 V
DC Output Current - maximum	25 A	21 A	18 A	12 A	10 A	9 A
DC Output Power - maximum	695 W	875 W	1000 W	1000 W	1000 W	1000 W
Interlock Current - maximum	1 A	1 A	1 A	0.5 A	0.5 A	0.5 A
Battery Type	Specific to selected algorithm					
Reverse Polarity	Electronic protection - auto-reset					
Short Circuit	Electronic current limit					

AC Input

AC Input Voltage - range	85 - 265 VAC
AC Input Voltage - nominal	120 VAC / 230 VAC rms
AC Input Frequency	45 - 65 Hz
AC Input Current - maximum/nominal	12 A / 9.5 A rms @ 120 VAC or 5 A rms @ 230 VAC
AC Power Factor - nominal	> 0.99 @ 120 VAC / > 0.98 @ 230 VAC

Mechanical

Dimensions	28.0 x 24.6 x 11.0 cm (11 x 9.7 x 4.3")
Weight	< 5 kg (< 11 lbs) w/standard output cord
AC input connector	IEC320/C14 (require ≥ 1.8m localized cord)
DC output connector	OEM specific w/12AWG wire

Environmental

Enclosure	IP66 (NEMA4)
Operating Temperature	-30°C to +50°C (-22°F to 122°F), derated above 30°C (86°F), below 0°C (32°F)
Storage Temperature	-40°C to +70°C (-40°F to 158°F)

Regulatory

Safety	UL approved to UL1564 3rd Ed., and CSA 107.2, EN 60335-2-29, Designed to meet UL2202 1st Ed.
Emissions	FCC Part 15/ICES 003 Class A, EN 55011, EN 61000-3-2, EN 61000-3-3
Immunity	EN 61000-4-2/-3/-4/-5/-6/-11

Operation

AC ON	Solid YELLOW AC LED
>80% Charge Indicator	Solid YELLOW Charge LED
100% Charge Indicator	Solid GREEN Finish LED
Fault Indicator	Flash RED Fault LED
DC Ammeter	LED Bargraph (6 level)
Long-term Storage Mode	Auto-restart if battery voltage < 2.1 V/cell or 30 days elapse

Special Features

Battery Temperature Monitoring with Multiple Temperature Sensor Options
External Communications
PC-based configuration software for field programmability
Advanced Microprocessor with Integrated Charge Cycle and Event Tracking

Options

- OEM Specific DC Output Cord
- Localized AC Input Cord
- Reverse or Dry Contact Interlocks
- Handle



Rear view of QuiQ ICON configuration shows inline DC and signal connectors (charger output on left, signal I/O on right). Mate with OEM specific output cords.

QuiQ and the Power in Motion slogan are trademarks of Delta-Q Technologies Corp. Copyright © 2006 Delta-Q Technologies Corp.

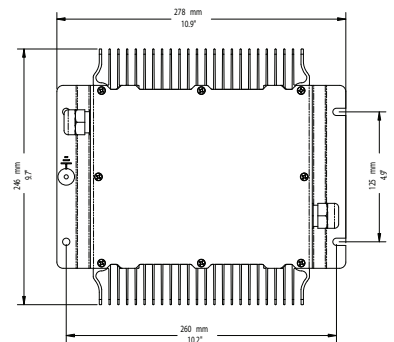

For more information contact:

Delta-Q Technologies Corp.
3755 Willingdon Ave
Burnaby, BC V5G 3H3
Canada

tel: 604.327.8244
fax: 604.327.8246
email: info@delta-q.com
www.delta-q.com

720-0001 Rev 5 October 7, 2011



Power in Motion™