

EXAMINED BY :	EMERGING DISPLAY TECHNOLOGIES CORPORATION	FILE NO . CAS-0006832
<i>Yung Chang Hu</i>		ISSUE : MAY.20, 2011
APPROVED BY:		TOTAL PAGE : 24
<i>David Chang</i>		VERSION : 6
CUSTOMER ACCEPTANCE SPECIFICATIONS		
<div style="border: 1px solid black; border-radius: 15px; padding: 20px; margin: 20px auto; width: 80%;"> <p>MODEL NO. :</p> <p style="text-align: center;"><u>ET070001DM6</u></p> <p style="text-align: center;">(RoHS)</p> <p>FOR MESSRS :</p> <p>_____</p> </div>		
CUSTOMER'S APPROVAL		
DATE :		
_____		
BY :		
_____		

EMERGING DISPLAY TECHNOLOGIES CORPORATION

MODEL NO. ET070001DM6	VERSION 6	PAGE 0-1
--------------------------	--------------	-------------

RECORDS OF REVISION

DOC . FIRST ISSUE

MAR.04, 2009

DATE	REVISED PAGE NO.	SUMMARY																																				
MAR.19, 2009	3	<p>4. ELECTRICAL CHARACTERISTICS</p> <table border="1"> <thead> <tr> <th>PARAMETER</th> <th>SYMBOL</th> <th>CONDITION</th> <th>MIN.</th> <th>TYP.</th> <th>MAX.</th> <th>UNIT</th> <th>REMARK</th> </tr> </thead> <tbody> <tr> <td>POWER SUPPLY CURRENT FOR LCM</td> <td>ICC</td> <td>VCC = 3.3V</td> <td>—</td> <td>(170)</td> <td>(220)</td> <td>mA</td> <td>VSS=0</td> </tr> </tbody> </table> <p style="text-align: center;">↓</p> <table border="1"> <thead> <tr> <th>PARAMETER</th> <th>SYMBOL</th> <th>CONDITION</th> <th>MIN.</th> <th>TYP.</th> <th>MAX.</th> <th>UNIT</th> <th>REMARK</th> </tr> </thead> <tbody> <tr> <td>POWER SUPPLY CURRENT FOR LCM</td> <td>ICC</td> <td>VCC = 3.3V</td> <td>—</td> <td>150</td> <td>200</td> <td>mA</td> <td>VSS=0</td> </tr> </tbody> </table>	PARAMETER	SYMBOL	CONDITION	MIN.	TYP.	MAX.	UNIT	REMARK	POWER SUPPLY CURRENT FOR LCM	ICC	VCC = 3.3V	—	(170)	(220)	mA	VSS=0	PARAMETER	SYMBOL	CONDITION	MIN.	TYP.	MAX.	UNIT	REMARK	POWER SUPPLY CURRENT FOR LCM	ICC	VCC = 3.3V	—	150	200	mA	VSS=0				
PARAMETER	SYMBOL	CONDITION	MIN.	TYP.	MAX.	UNIT	REMARK																															
POWER SUPPLY CURRENT FOR LCM	ICC	VCC = 3.3V	—	(170)	(220)	mA	VSS=0																															
PARAMETER	SYMBOL	CONDITION	MIN.	TYP.	MAX.	UNIT	REMARK																															
POWER SUPPLY CURRENT FOR LCM	ICC	VCC = 3.3V	—	150	200	mA	VSS=0																															
	7	<p>7. OUTLINE DIMENSIONS MARK <math>\Delta</math> : ADD TAPE</p>																																				
JUL.10, 2009	2	<p>3.1 ELECTRICAL ABSOLUTE MAXIMUM RATINGS.</p> <table border="1"> <thead> <tr> <th>PARAMETER</th> <th>SYMBOL</th> <th>MIN.</th> <th>MAX.</th> <th>UNIT</th> <th>REMARK</th> </tr> </thead> <tbody> <tr> <td>LED BACKLIGHT POWER DISSIPATION</td> <td>PD</td> <td>—</td> <td>2950</td> <td>mW</td> <td></td> </tr> <tr> <td>LED BACKLIGHT POWER CURRENT</td> <td>IF</td> <td>—</td> <td>800</td> <td>mA</td> <td></td> </tr> </tbody> </table> <p style="text-align: center;">↓</p> <table border="1"> <thead> <tr> <th>PARAMETER</th> <th>SYMBOL</th> <th>MIN.</th> <th>MAX.</th> <th>UNIT</th> <th>REMARK</th> </tr> </thead> <tbody> <tr> <td>LED BACKLIGHT POWER DISSIPATION</td> <td>PD</td> <td>—</td> <td>2592</td> <td>mW</td> <td></td> </tr> <tr> <td>LED BACKLIGHT POWER CURRENT</td> <td>IF</td> <td>—</td> <td>240</td> <td>mA</td> <td></td> </tr> </tbody> </table>	PARAMETER	SYMBOL	MIN.	MAX.	UNIT	REMARK	LED BACKLIGHT POWER DISSIPATION	PD	—	2950	mW		LED BACKLIGHT POWER CURRENT	IF	—	800	mA		PARAMETER	SYMBOL	MIN.	MAX.	UNIT	REMARK	LED BACKLIGHT POWER DISSIPATION	PD	—	2592	mW		LED BACKLIGHT POWER CURRENT	IF	—	240	mA	
PARAMETER	SYMBOL	MIN.	MAX.	UNIT	REMARK																																	
LED BACKLIGHT POWER DISSIPATION	PD	—	2950	mW																																		
LED BACKLIGHT POWER CURRENT	IF	—	800	mA																																		
PARAMETER	SYMBOL	MIN.	MAX.	UNIT	REMARK																																	
LED BACKLIGHT POWER DISSIPATION	PD	—	2592	mW																																		
LED BACKLIGHT POWER CURRENT	IF	—	240	mA																																		
SEP.28, 2009	3	<p>4. ELECTRICAL CHARACTERISTICS</p> <table border="1"> <thead> <tr> <th>PARAMETER</th> <th>SYMBOL</th> <th>CONDITION</th> <th>MIN.</th> <th>TYP.</th> <th>MAX.</th> <th>UNIT</th> <th>REMARK</th> </tr> </thead> <tbody> <tr> <td>POWER SUPPLY VOLTAGE</td> <td>VCC</td> <td></td> <td>3.0</td> <td>3.3</td> <td>3.6</td> <td>V</td> <td>VSS=0</td> </tr> </tbody> </table> <p style="text-align: center;">↓</p> <table border="1"> <thead> <tr> <th>PARAMETER</th> <th>SYMBOL</th> <th>CONDITION</th> <th>MIN.</th> <th>TYP.</th> <th>MAX.</th> <th>UNIT</th> <th>REMARK</th> </tr> </thead> <tbody> <tr> <td>POWER SUPPLY VOLTAGE</td> <td>VCC</td> <td></td> <td>3.2</td> <td>3.3</td> <td>3.6</td> <td>V</td> <td>VSS=0</td> </tr> </tbody> </table>	PARAMETER	SYMBOL	CONDITION	MIN.	TYP.	MAX.	UNIT	REMARK	POWER SUPPLY VOLTAGE	VCC		3.0	3.3	3.6	V	VSS=0	PARAMETER	SYMBOL	CONDITION	MIN.	TYP.	MAX.	UNIT	REMARK	POWER SUPPLY VOLTAGE	VCC		3.2	3.3	3.6	V	VSS=0				
PARAMETER	SYMBOL	CONDITION	MIN.	TYP.	MAX.	UNIT	REMARK																															
POWER SUPPLY VOLTAGE	VCC		3.0	3.3	3.6	V	VSS=0																															
PARAMETER	SYMBOL	CONDITION	MIN.	TYP.	MAX.	UNIT	REMARK																															
POWER SUPPLY VOLTAGE	VCC		3.2	3.3	3.6	V	VSS=0																															
APR.23, 2010	13	<p>10.4 SELECTION OF SCANNING MODE</p>																																				
MAY.20, 2011	1	<p>1.1 APPLICATION NOTES FOR CONTROLLER/DRIVER → DATA SHEETS FOR CONTROLLER/DRIVER</p>																																				
	2	<p>3.2 ENVIRONMENTAL ABSOLUTE MAXIMUM RATINGS SHOCK : 10m SECONDS → 10ms</p>																																				
	3	<p>4. ELECTRICAL CHARACTERISTICS</p> <table border="1"> <thead> <tr> <th>PARAMETER</th> <th>SYMBOL</th> <th>CONDITION</th> <th>MIN.</th> <th>TYP.</th> <th>MAX.</th> <th>UNIT</th> <th>REMARK</th> </tr> </thead> <tbody> <tr> <td>LED LIFE TIME</td> <td></td> <td></td> <td></td> <td></td> <td></td> <td></td> <td></td> </tr> </tbody> </table> <p style="text-align: center;">↓</p> <table border="1"> <thead> <tr> <th>PARAMETER</th> <th>SYMBOL</th> <th>CONDITION</th> <th>MIN.</th> <th>TYP.</th> <th>MAX.</th> <th>UNIT</th> <th>REMARK</th> </tr> </thead> <tbody> <tr> <td>LED LIFE TIME</td> <td></td> <td>1hr/20mA (PER LED)</td> <td>25K</td> <td>—</td> <td>—</td> <td>hrs</td> <td>NOTE (3) NOTE (4)</td> </tr> </tbody> </table> <p>ADD NOTE(3), NOTE (4)</p>	PARAMETER	SYMBOL	CONDITION	MIN.	TYP.	MAX.	UNIT	REMARK	LED LIFE TIME								PARAMETER	SYMBOL	CONDITION	MIN.	TYP.	MAX.	UNIT	REMARK	LED LIFE TIME		1hr/20mA (PER LED)	25K	—	—	hrs	NOTE (3) NOTE (4)				
PARAMETER	SYMBOL	CONDITION	MIN.	TYP.	MAX.	UNIT	REMARK																															
LED LIFE TIME																																						
PARAMETER	SYMBOL	CONDITION	MIN.	TYP.	MAX.	UNIT	REMARK																															
LED LIFE TIME		1hr/20mA (PER LED)	25K	—	—	hrs	NOTE (3) NOTE (4)																															
	8	<p>6.1 OPTICAL CHARACTERISTICS <math>\theta_y = -90^\circ \rightarrow \theta_y = +90^\circ</math></p>																																				
	15	<p>12.2 INSPECTION CONDITIONS DELETE TEXT : NON-OPERATION CONDITION, OPERATION CONDITION</p>																																				
	22	<p>12.4.1 STANDARD SPECIFICATIONS FOR RELIABILITY OF LCD MODULE NO.6 : -30°C FOR 30 MINUTES ~ +80°C FOR 30 MINUTES →</p> <p>NO.7 : ADD ACCORDING TO IEC-61000-4-2</p>																																				

EMERGING DISPLAY  
TECHNOLOGIES CORPORATION

MODEL NO.

ET070001DM6

VERSION

6

PAGE

0-2

TABLE OF CONTENTS

NO.	ITEM	PAGE
1.	GENERAL SPECIFICATIONS -----	1
2.	MECHANICAL SPECIFICATIONS -----	1
3.	ABSOLUTE MAXIMUM RATINGS -----	2
4.	ELECTRICAL CHARACTERISTICS -----	3
5.	TIMING CHART -----	4 ~ 6
6.	OPTICAL CHARACTERISTICS -----	7, 8
7.	OUTLINE DIMENSIONS -----	9
8.	BLOCK DIAGRAM -----	10
9.	DETAIL DRAWING OF DOT MATRIX -----	11
10.	INTERFACE SIGNALS -----	12, 13
11.	POWER SUPPLY -----	14
12.	INSPECTION CRITERION -----	15 ~ 24

EMERGING DISPLAY  
TECHNOLOGIES CORPORATION

MODEL NO.

ET070001DM6

VERSION

6

PAGE

1

## 1. GENERAL SPECIFICATIONS

### 1.1 DATA SHEETS FOR CONTROLLER/DRIVER

PLEASE REFER TO :

HIMAX HX8262-A

HIMAX HX8678-A

### 1.2 MATERIAL SAFETY DESCRIPTION

ASSEMBLIES SHALL COMPLY WITH EUROPEAN ROHS REQUIREMENTS, INCLUDING PROHIBITED MATERIALS/COMPONENTS CONTAINING LEAD, MERCURY, CADMIUM, HEXAVALENT CHROMIUM, POLYBROMINATED BIPHENYLS (PBB) AND POLYBROMINATED DIPHENYL ETHERS (PBDE)

## 2. MECHANICAL SPECIFICATIONS

(1) DISPLAY SIZE	-----	7 inch
(2) NUMBER OF DOTS	-----	800W * (RGB) * 480H DOTS
(3) MODULE SIZE	-----	165W * 104.44H * 5.2D mm (WITHOUT FPC)
(4) ACTIVE AREA	-----	152.4W * 91.44H mm
(5) DOT SIZE	-----	0.0635W * 0.1905H mm
(6) PIXEL SIZE	-----	0.1905W * 0.1905H mm
(7) LCD TYPE	-----	TFT , TRANSMISSIVE, ANTE-GLARE
(8) COLOR	-----	262K
(9) VIEWING DIRECTION	-----	6 O'CLOCK
(10) BACK LIGHT	-----	LED , COLOR : WHITE
(11) INTERFACE MODE	-----	RGB(18BIT) PARALLEL (DE/SYNC MODE)

EMERGING DISPLAY  
TECHNOLOGIES CORPORATION

MODEL NO.

ET070001DM6

VERSION

6

PAGE

2

### 3. ABSOLUTE MAXIMUM RATINGS

#### 3.1 ELECTRICAL ABSOLUTE MAXIMUM RATINGS .

PARAMETER	SYMBOL	MIN.	MAX.	UNIT	REMARK
POWER SUPPLY VOLTAGE	VCC	-0.5	+7	V	VSS=0
INPUT VOLTAGE	V <sub>in</sub>	-0.3	VCC+0.3	V	VSS=0
LED BACKLIGHT POWER DISSIPATION	PD	—	2592	mW	
LED BACKLIGHT POWER CURRENT	IF	—	240	mA	

#### 3.2 ENVIRONMENTAL ABSOLUTE MAXIMUM RATINGS .

I T E M	OPERATING		STORAGE		REMARK
	MIN.	MAX.	MIN.	MAX.	
AMBIENT TEMPERATURE	-20°C	70°C	-30°C	80°C	NOTE ( 1 ) , ( 2 )
HUMIDITY	NOTE ( 3 )		NOTE ( 3 )		WITHOUT CONDENSATION
VIBRATION	—	2.45 m/s <sup>2</sup> ( 0.25 G )	—	11.76 m/s <sup>2</sup> ( 1.2 G )	5~20Hz , 1HR 20~500Hz(20Hz) , 1HR 20~500Hz(500Hz) , 1HR X,Y,Z,TOTAL 3HRS
SHOCK	—	29.4 m/s <sup>2</sup> ( 3 G )	—	490 m/s <sup>2</sup> ( 50 G )	10 ms XYZ DIRECTIONS 1 TIME EACH
CORROSIVE GAS	NOT ACCEPTABLE		NOT ACCEPTABLE		

NOTE ( 1 ) : Ta AT -30°C : 48HRS MAX .

80°C : 168HRS MAX .

NOTE ( 2 ) : BACKGROUND COLOR CHANGES SLIGHTLY DEPENDING ON AMBIENT TEMPERATURE  
THIS PHENOMENON IS REVERSIBLE.

NOTE ( 3 ) : Ta ≤ 60°C : 90%RH MAX (96HRS MAX).

Ta > 60°C : ABSOLUTE HUMIDITY MUST BE LOWER THAN THE HUMIDITY  
OF 90%RH AT 60°C(96HRS MAX).

EMERGING DISPLAY  
TECHNOLOGIES CORPORATION

MODEL NO.

ET070001DM6

VERSION

6

PAGE

3

## 4. ELECTRICAL CHARACTERISTICS

Ta = 25 °C

PARAMETER	SYMBOL	CONDITION	MIN.	TYP.	MAX.	UNIT	REMARK
POWER SUPPLY VOLTAGE	VCC	—	3.2	3.3	3.6	V	VSS=0
POWER SUPPLY CURRENT FOR LCM	ICC	VCC = 3.3V	—	150	200	mA	VSS=0
LOW LEVEL INPUT VOLTAGE	VIL	—	0	—	0.2*VCC	V	
HIGH LEVEL INPUT VOLTAGE	VIH	—	0.8*VCC	—	VCC	V	
OUTPUT LOW VOLTAGE	VOL	IOL = 400 $\mu$ A	0	—	0.2*VCC	V	
OUTPUT HIGH VOLTAGE	VOH	IOH = -400 $\mu$ A	0.8*VCC	—	VCC	V	
LED BACKLIGHT FORWARD VOLTAGE	V <sub>F</sub>	I <sub>F</sub> =160mA	9	9.9	10.8	V	NOTE (1)
LED LIFE TIME	—	I <sub>LED</sub> =20mA (PER. LED)	25K	—	—	hrs	NOTE (3) NOTE (4)

NOTE (1) : INTERNAL CIRCUIT DIAGRAM OF BACKLIGHT

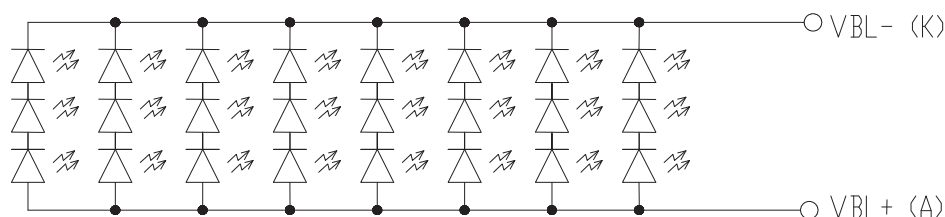

NOTE (2) : AMBIENT TEMP. VS. ALLOWABLE FORWARD CURRENT. (PER. LED)

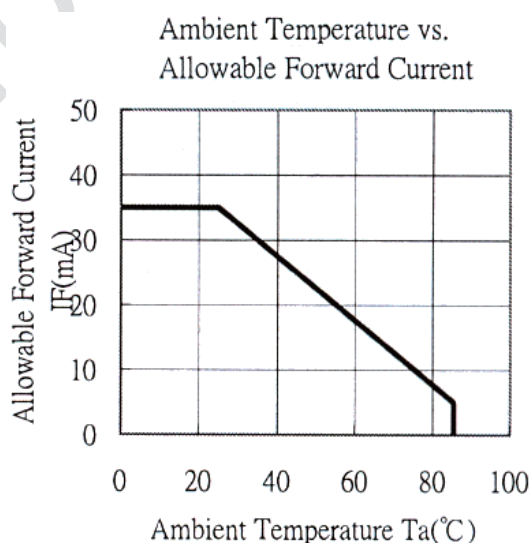

NOTE (3) : CONDITIONS; TA=25 °C, CONTINUOUS LIGHTING

NOTE (4) : DEFINITIONS OF FAILURE

- A. LCD LUMINANCE BECOMES HALF OF THE MINIMUM VALUE.
- B. LED DOESN'T LIGHT NORMALLY

EMERGING DISPLAY  
TECHNOLOGIES CORPORATION

MODEL NO.

ET070001DM6

VERSION

6

PAGE

4

## 5. TIMING CHART

## 5.1 AC ELECTRICAL CHARACTERISTICS

PARAMETER	SYMBOL	SPEC			UNIT
		MIN.	TYP.	MAX.	
HSYNC SETUP TIME	$T_{hst}$	6	—	—	ns
HSYNC HOLD TIME	$T_{hhd}$	6	—	—	ns
VSYNC SETUP TIME	$T_{vst}$	6	—	—	ns
VSYNC HOLD TIME	$T_{vhhd}$	6	—	—	ns
DATA SETUP TIME	$T_{dsu}$	6	—	—	ns
DATA HOLD TIME	$T_{dhhd}$	6	—	—	ns
DE SETUP TIME	$T_{esu}$	6	—	—	ns
SOURCE OUTPUT SETTLING TIME	$T_{ST}$	—	—	15	$\mu$ s
SOURCE OUTPUT LOADING R	$R_{SL}$	—	2	—	K ohm
SOURCE OUTPUT LOADING C	$C_{SL}$	—	60	—	pF

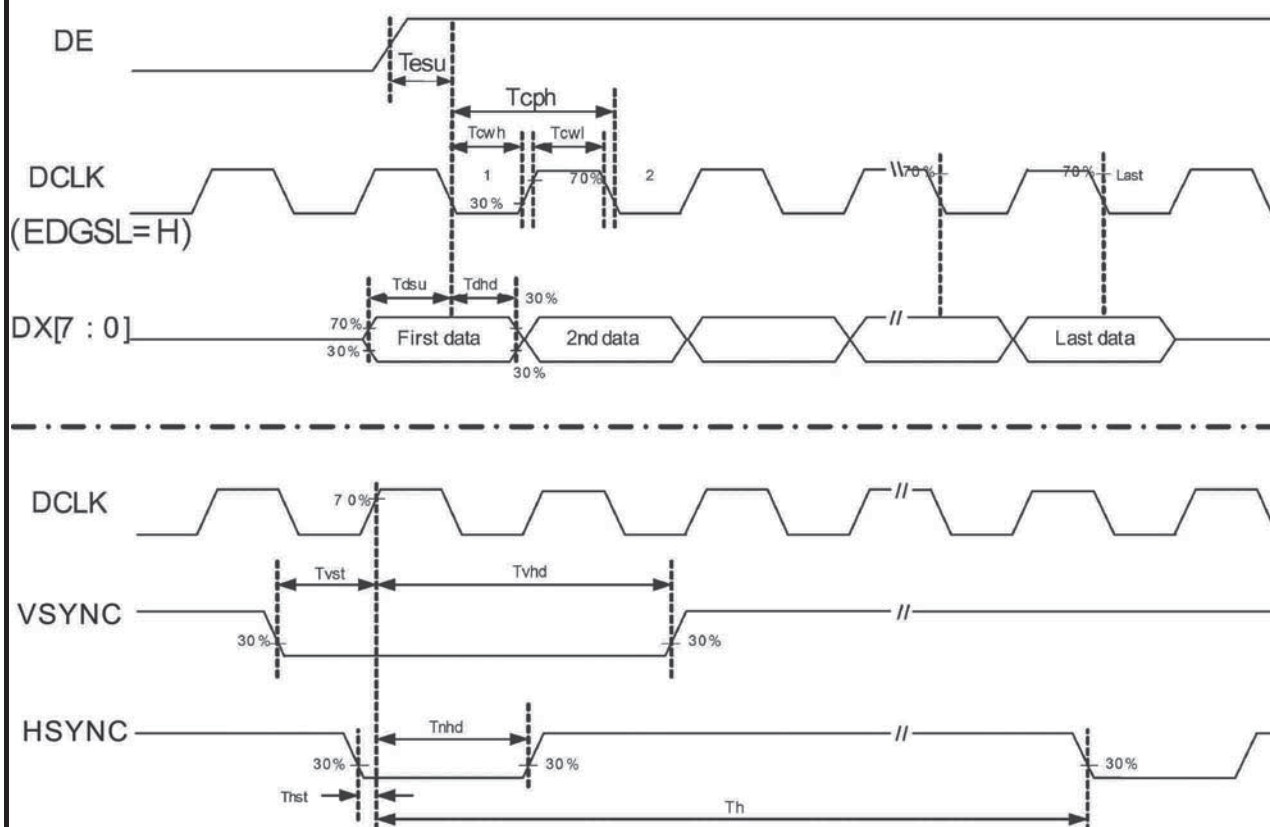

5.2 SYNC MODE SIGNAL CHARACTERISTICS

PARAMETER	SYMBOL	SPEC			UNIT
		MIN.	TYP.	MAX.	
DCLK FREQUENCY	$F_{CPH}$	—	33.26	—	MHz
DCLK PERIOD	$T_{CPH}$	—	30.06	—	ns
DCLK PULSE DUTY	$T_{CWH}$	40	50	60	%
HSYNC PERIOD	$T_H$	930	1056	1057	$T_{CPH}$
HSYNC PULSE WIDTH	$T_{WH}$	1	128	—	$T_{CPH}$
HSYNC -FIRST HORIZONTAL DATA TIME	$T_{HS}$	—	216	—	$T_{CPH}$
HSYNC ACTIVE TIME	$T_{HA}$	—	800	—	$T_{CPH}$
VSYNC PERIOD	$T_V$	—	525	—	$T_H$
VSYNC PULSE WIDTH	$T_{WV}$	1	2	—	$T_H$
VSYNC -DE TIME	$T_{VS}$	—	35	—	$T_H$
VSYNC ACTIVE TIME	$T_{VA}$	—	480	—	$T_H$

(EDGSL=H)

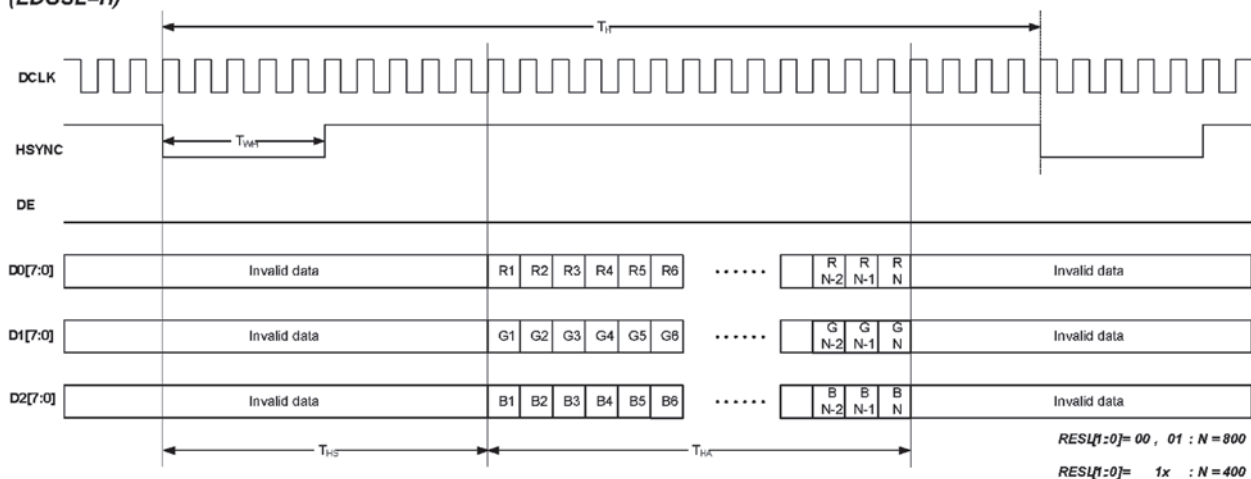

SYNC Mode Horizontal Data Format

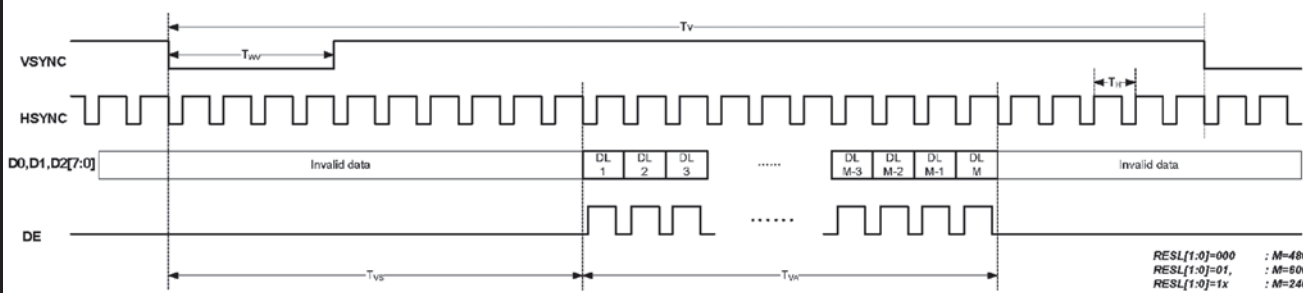

SYNC Mode Vertical Data Format



EMERGING DISPLAY TECHNOLOGIES CORPORATION

MODEL NO.	VERSION	PAGE
ET070001DM6	6	6

5.3 DE MODE SIGNAL CHARACTERISTICS

PARAMETER	SYMBOL	SPEC			UNIT
		MIN.	TYP.	MAX.	
DCLK FREQUENCY	$F_{CPH}$	—	33.26	—	MHz
DCLK PERIOD	$T_{CPH}$	—	30.06	—	ns
DCLK PULSE DUTY	$T_{CWH}$	40	50	60	%
DE PERIOD	$T_{DEH} + T_{DEL}$	1000	1056	1200	$T_{CPH}$
DE PULSE WIDTH	$T_{DEH}$	—	800	—	$T_{CPH}$
DE FRAME BLANKING	$T_{DEB}$	10	45	110	$T_{DEH} + T_{DEL}$
DE FRAME WIDTH	$T_{DE}$	—	480	—	$T_{DEH} + T_{DEL}$
OEV PULSE WIDTH	$T_{OEV}$	—	150	—	$T_{CPH}$
CKV PULSE WIDTH	$T_{CKV}$	—	133	—	$T_{CPH}$
DE(INTERNAL)-STV TIME	$T_1$	—	4	—	$T_{CPH}$
DE(INTERNAL)-CKV TIME	$T_2$	—	40	—	$T_{CPH}$
DE(INTERNAL)-OEV TIME	$T_3$	—	23	—	$T_{CPH}$
DE(INTERNAL)-POL TIME	$T_4$	—	157	—	$T_{CPH}$
STV PULSE WIDTH	—	—	1	—	$T_H$

NOTE : (1)  $T_{HS} + T_{HA} < T_H$

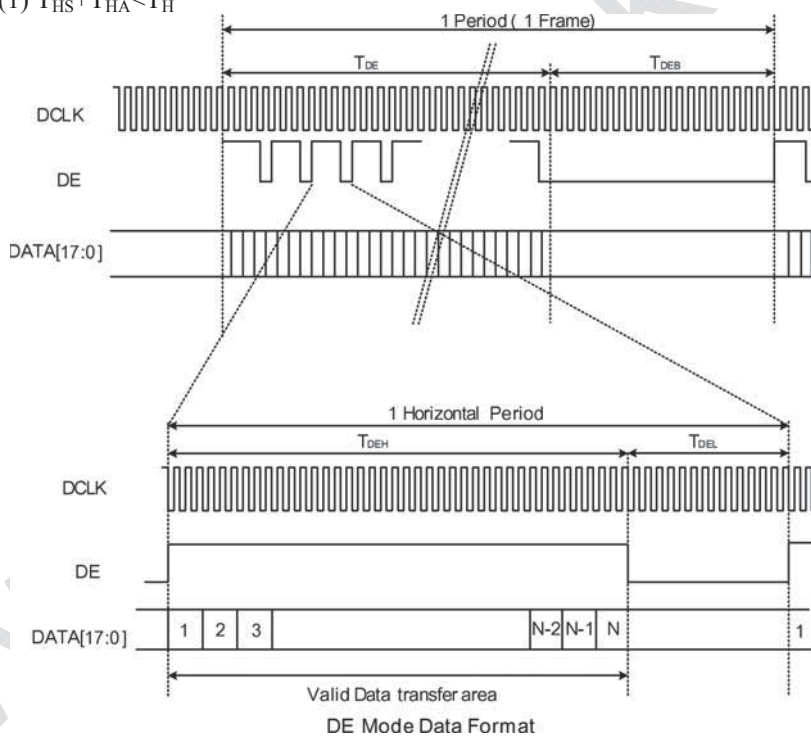

5.4 HARDWARE RESET TIMING

PARAMETER	SYMBOL	SPEC			UNIT
		MIN.	TYP.	MAX.	
RESETB LOW PULSE WIDTH	$Trstw$	10	—	—	$\mu s$
NEGATIVE NOISE PULSE WIDTH	$Tnr$	—	—	4	$\mu s$
RESET START TIME	$Tst$	4	—	—	$\mu s$

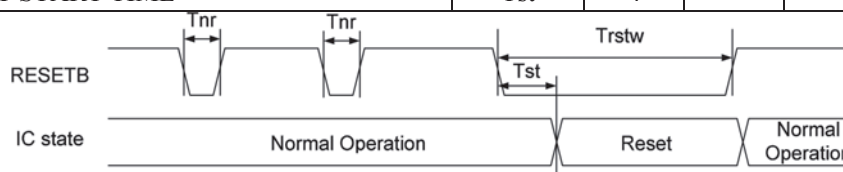

EMERGING DISPLAY  
TECHNOLOGIES CORPORATION

MODEL NO .

E T 0 7 0 0 0 1 D M 6

VERSION

6

PAGE

7

## 6. OPTICAL CHARACTERISTICS (NOTE1)

## 6.1 OPTICAL CHARACTERISTICS

Ta = 25 ± 2 °C

I T E M		SYMBOL	CONDITION	MIN.	TYP.	MAX.	UNIT	REMARK	
VIEWING ANGLE		$\theta_{y+}$	CR ≥ 10	60	65	—	deg.	(2) (3)	
		$\theta_{y-}$		$\theta_x=0^\circ$	60	65			—
		$\theta_{x+}$		$\theta_y=0^\circ$	65	70			—
		$\theta_{x-}$			65	70			—
CONTRAST RATIO		CR	$\theta_x=0^\circ, \theta_y=0^\circ$	300	350	—	—	(3)	
RESPONSE TIME		$T_R$ ( rise )	$\theta_x=0^\circ, \theta_y=0^\circ$	—	5	10	msec	(4)	
		$T_F$ ( fall )		—	15	20			
THE BRIGHTNESS OF MODULE		B	$\theta_x=0^\circ, \theta_y=0^\circ$ IF = 160mA	300	—	—	cd/m <sup>2</sup>	(5)	
COLOR OF CIE COORDINATE	WHITE	$W_x$	$\theta_x=0^\circ, \theta_y=0^\circ$ IF = 160 mA NTSC : 45 %	0.26	0.31	0.36	—	(6)	
		$W_y$		0.29	0.34	0.39			
	RED	$R_x$		0.52	0.57	0.62	—		
		$R_y$		0.30	0.35	0.40			
	GREEN	$G_x$		0.29	0.34	0.39	—		
		$G_y$		0.52	0.57	0.62			
	BLUE	$B_x$		0.115	0.155	0.19	—		
		$B_y$		0.085	0.12	0.165			
THE UNIFORMITY OF MODULE		—	$\theta_x=0^\circ, \theta_y=0^\circ$ IF = 160 mA	75	80	—	%	(5)	

NOTE (1) : TEST EQUIPMENT SETUP :

AFTER STABILIZING AND LEAVING THE PANEL ALONE AT A GIVEN TEMPERATURE FOR 30 MINUTES , THE MEASUREMENT SHOULD BE EXECUTED. MEASUREMENT SHOULD BE EXECUTED IN A STABLE , WINDLESS , AND DARK ROOM. OPTICAL SPECIFICATIONS ARE MEASURED BY TOPCON BM-7 (FAST) WITH A VIEWING ANGLE OF 1° AT A DISTANCE OF 50cm AND NORMAL DIRECTION.

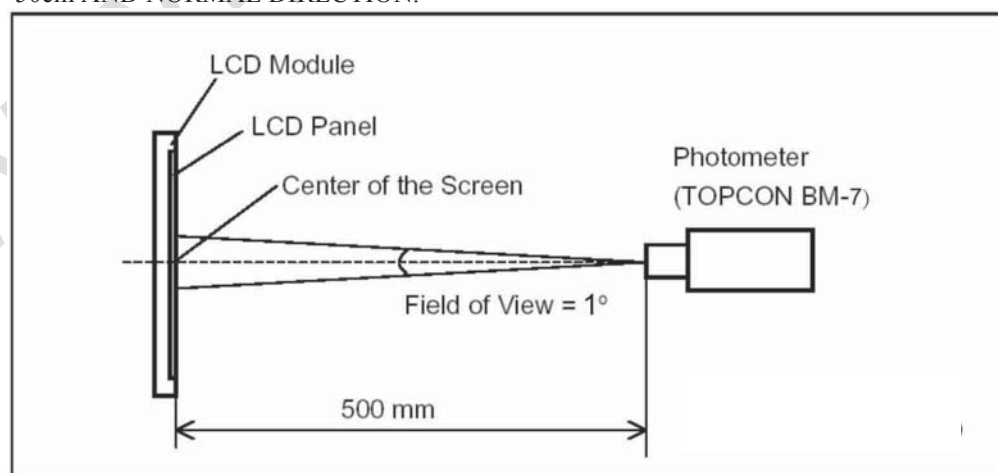

EMERGING DISPLAY  
TECHNOLOGIES CORPORATION

MODEL NO.	VERSION	PAGE
ET070001DM6	6	8

NOTE (2) : DEFINITION OF VIEWING ANGLE :

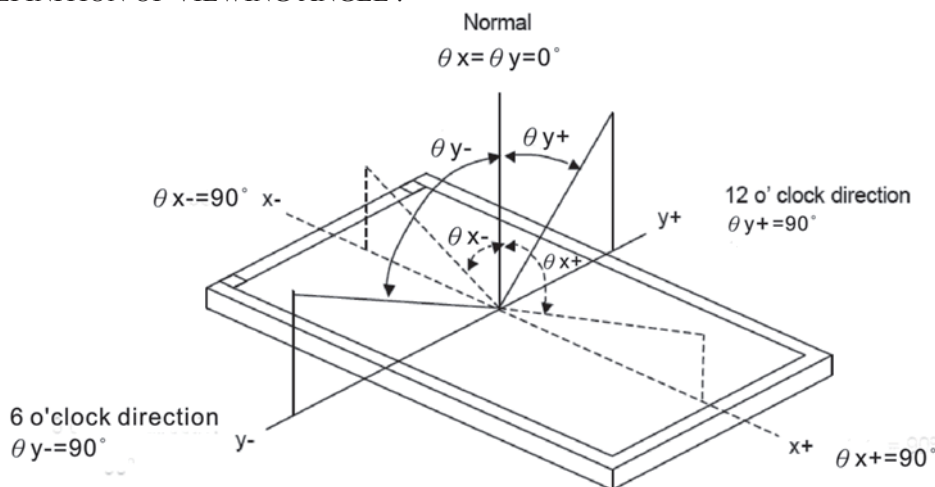

NOTE (3) : DEFINITION OF CONTRAST RATIO :

$$\text{CONTRAST RATIO(CR)} = \frac{\text{BRIGHTNESS MEASURED WHEN LCD IS AT "WHITE STATE"}}{\text{BRIGHTNESS MEASURED WHEN LCD IS AT "BLACK STATE"}}$$

NOTE (4) : DEFINITION OF RESPONSE TIME : TR AND TF

THE FIGURE BELOW IS THE OUTPUT SIGNAL OF THE PHOTO DETECTOR.

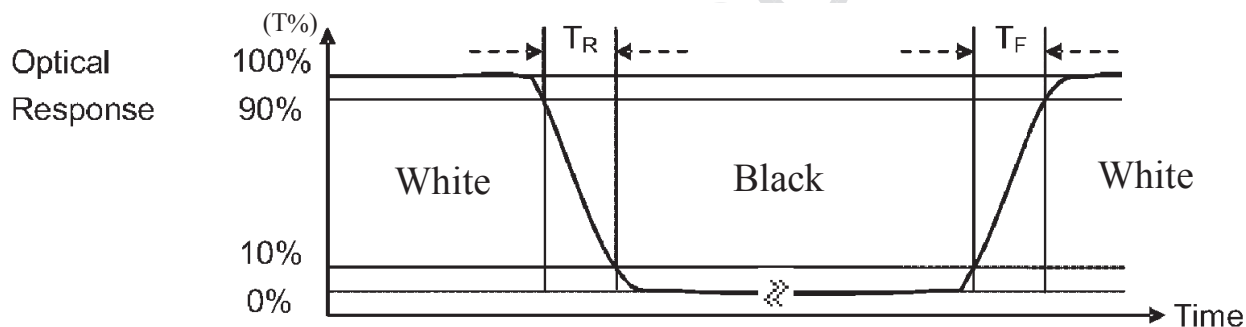

NOTE (5) : BRIGHTNESS MEASURED WHEN LCD IS AT "WHITE STATE"

NOTE (6) : THE 100% TRANSMISSION IS DEFINED AS THE TRANSMISSION OF LCD PANEL WHEN ALL THE INPUT TERMINALS OF MODULE ARE ELECTRICALLY OPENED.

6.2 THE TEST METHOD OF BRIGHTNESS AND UNIFORMITY

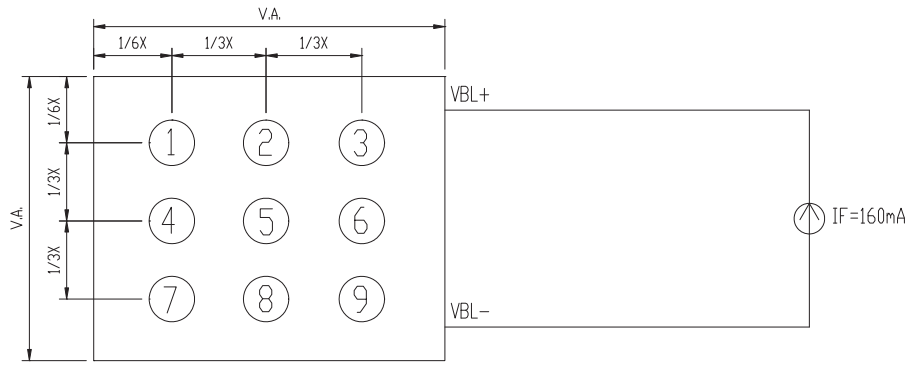

6.3 THE CALCULATING METHOD OF UNIFORMITY

$$\text{UNIFORMITY} = \left[ 1 - \frac{\text{MAXIMUM BRIGHTNESS} - \text{MINIMUM BRIGHTNESS}}{\text{AVERAGE BRIGHTNESS}} \right] \times 100\%$$

EMERGING DISPLAY TECHNOLOGIES CORPORATION	MODEL NO.	VERSION	PAGE
	ET070001DM6	6	9

7. OUTLINE DIMENSIONS

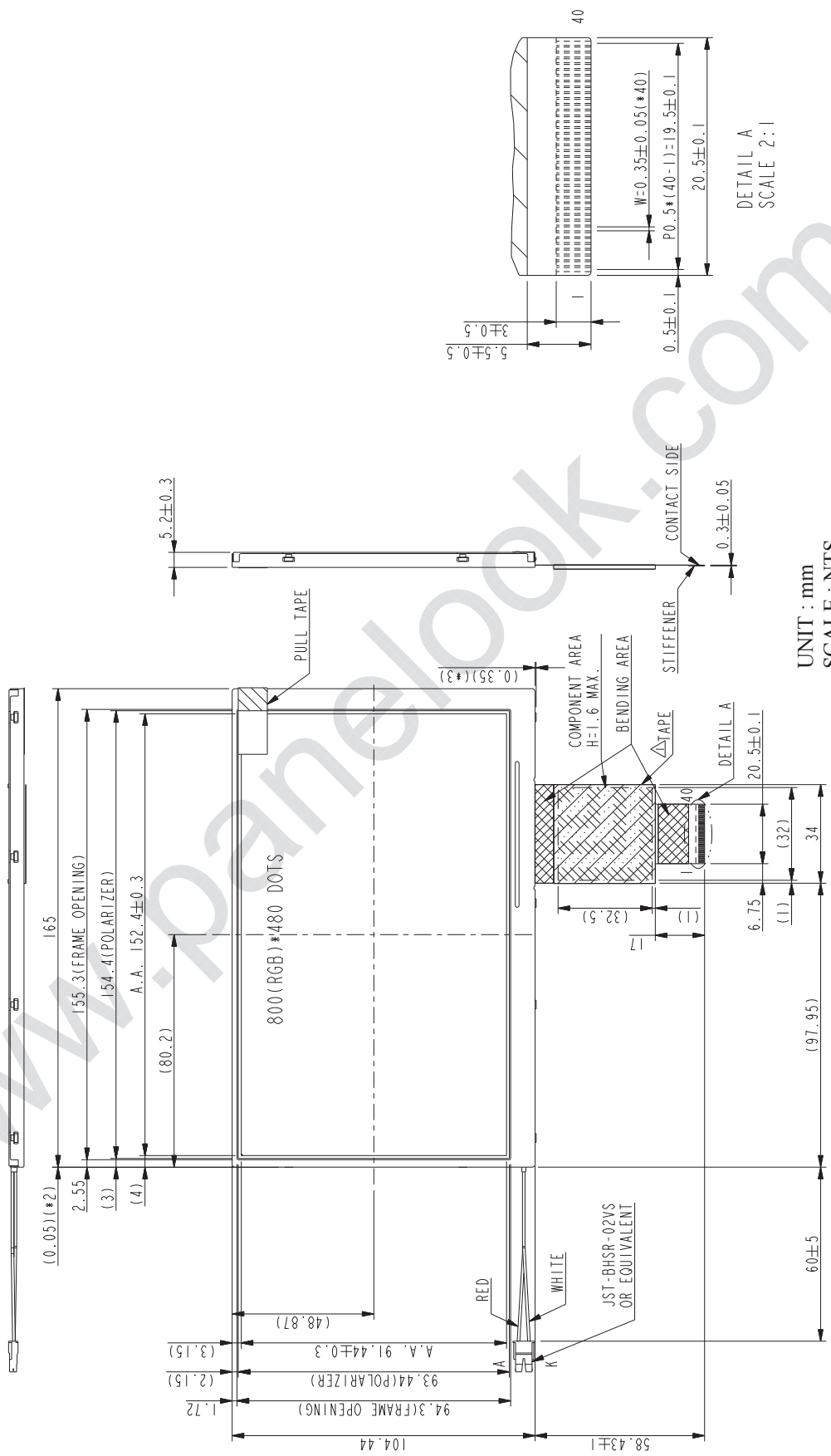

UNIT : mm  
SCALE : NTS

NOT SPECIFIED TOLERANCE IS ± 0.5  
NOTE(1):RECOMMEND MATCH CONNECTOR KYOCERA:04 6240 040 SERIES  
NOTE(2) : MARK △ MODIFY (NUMBER NOTE MODIFY VERSION)

VIEWING DIRECTION  
Best Contrast but with Gray Level Inversion

EMERGING DISPLAY  
TECHNOLOGIES CORPORATION

MODEL NO.	VERSION	PAGE
ET070001DM6	6	10

8. BLOCK DIAGRAM

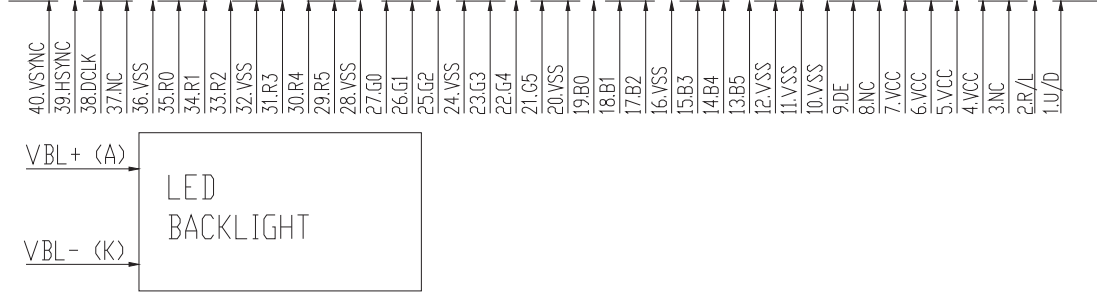
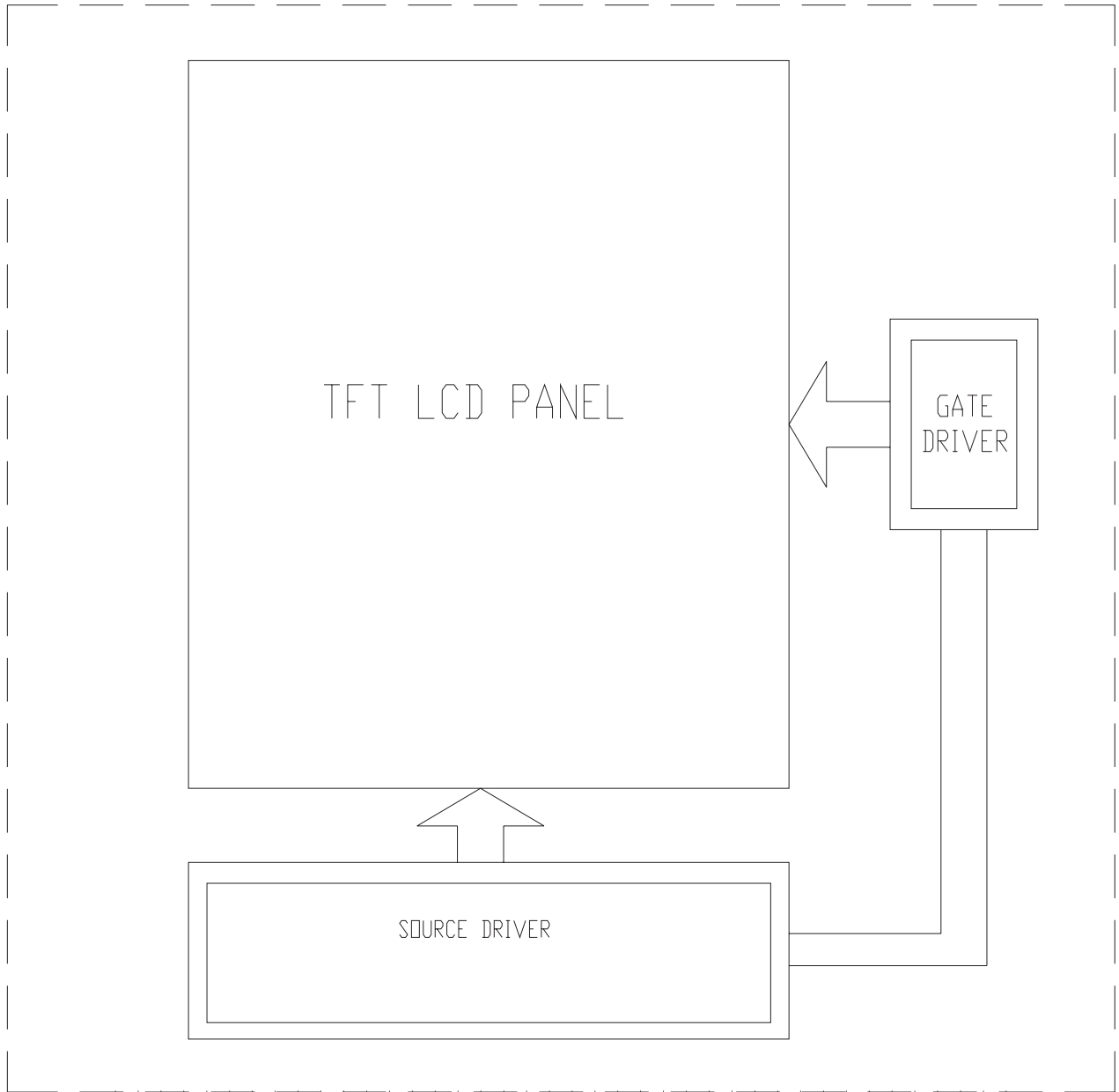

EMERGING DISPLAY  
TECHNOLOGIES CORPORATION

MODEL NO.

ET070001DM6

VERSION

6

PAGE

11

## 9. DETAIL DRAWING OF DOT MATRIX

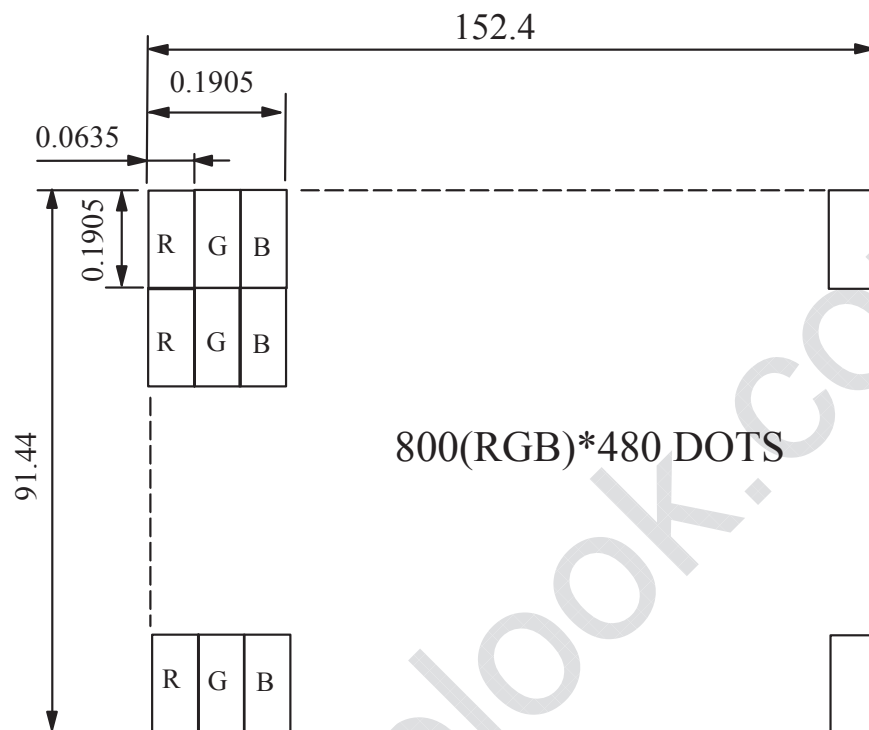

UNIT : mm

SCALE : NTS

NOT SPECIFIED TOLERANCE IS  $\pm 0.1$ DOTS MATRIX TOLERANCE IS  $\pm 0.01$

EMERGING DISPLAY  
TECHNOLOGIES CORPORATION

MODEL NO.

ET070001DM6

VERSION

6

PAGE

12

## 10. INTERFACE SIGNALS

PIN NO	SYMBOL	I/O	FUNCTION
1	U/D	I	U/D=H:OUT1→OUT2→-----→OUT480 U/D=L:OUT480→-----→OUT2→OUT1
2	R/L	I	R/L= H:OUT1→OUT2→-----→OUT800 R/L=L:OUT800→-----→OUT2→OUT1
3	NC	—	NC
4	VCC	P	POWER SUPPLY ( 3.3V)
5	VCC	P	POWER SUPPLY ( 3.3V)
6	VCC	P	POWER SUPPLY ( 3.3V)
7	VCC	P	POWER SUPPLY ( 3.3V)
8	NC	—	NC
9	DE	I	DATA ENABLE INPUT
10	VSS	P	GROUND
11	VSS	P	GROUND
12	VSS	P	GROUND
13	B5	I	BLUE DATA BIT5
14	B4	I	BLUE DATA BIT4
15	B3	I	BLUE DATA BIT3
16	VSS	P	GROUND
17	B2	I	BLUE DATA BIT2
18	B1	I	BLUE DATA BIT1
19	B0	I	BLUE DATA BIT0
20	VSS	P	GROUND
21	G5	I	GREEN DATA BIT 5
22	G4	I	GREEN DATA BIT 4
23	G3	I	GREEN DATA BIT 3
24	VSS	P	GROUND
25	G2	I	GREEN DATA BIT 2
26	G1	I	GREEN DATA BIT 1
27	G0	I	GREEN DATA BIT 0
28	VSS	P	GROUND
29	R5	I	RED DATA BIT 5
30	R4	I	RED DATA BIT 4

# EMERGING DISPLAY TECHNOLOGIES CORPORATION

MODEL NO.

ET070001DM6

VERSION

6

PAGE

13

31	R3	I	RED DATA BIT 3
32	VSS	P	GROUND
33	R2	I	RED DATA BIT 2
34	R1	I	RED DATA BIT 1
35	R0	I	RED DATA BIT 0
36	VSS	P	GROUND
37	NC	—	NC
38	DCLK	I	DOT DATA COLOCK
39	HSYNC	I	HORIZONTAL SYNC INPUT
40	VSYSN	I	VERTICAL SYNC INPUT

## 10.1 LED B/L INTERFACE

PIN NO	SYMBOL	FUNCTION
1	VBL+(A)	POWER SUPPLY FOR LED BACKLIGHT (ANODE)
2	VBL-(K)	POWER SUPPLY FOR LED BACKLIGHT (CATHODE)

## 10.2 SELECTION OF SCANNING MODE

R/L=H, U/D=L

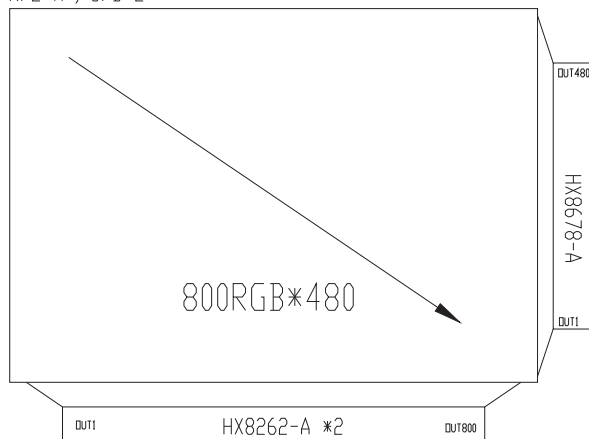

R/L=L, U/D=L

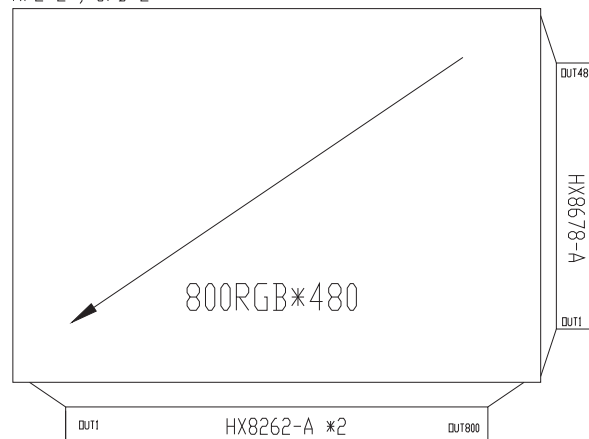

R/L=H, U/D=H

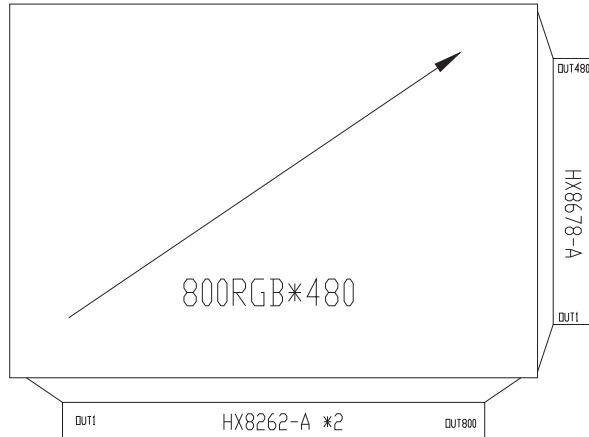

R/L=L, U/D=H

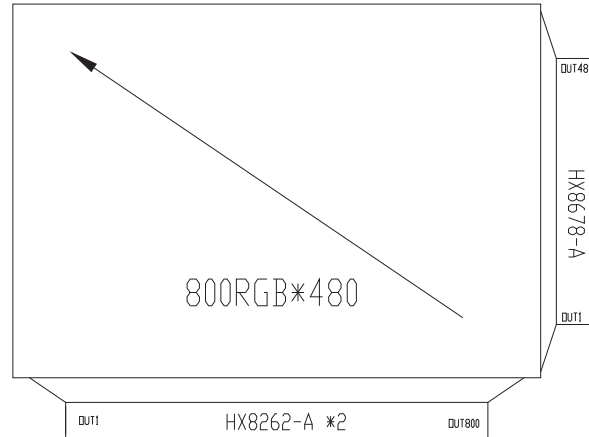



EMERGING DISPLAY  
TECHNOLOGIES CORPORATION

MODEL NO.

ET070001DM6

VERSION

6

PAGE

14

## 1.1. POWER SUPPLY

## 1.1.1 POWER SUPPLY FOR LCM

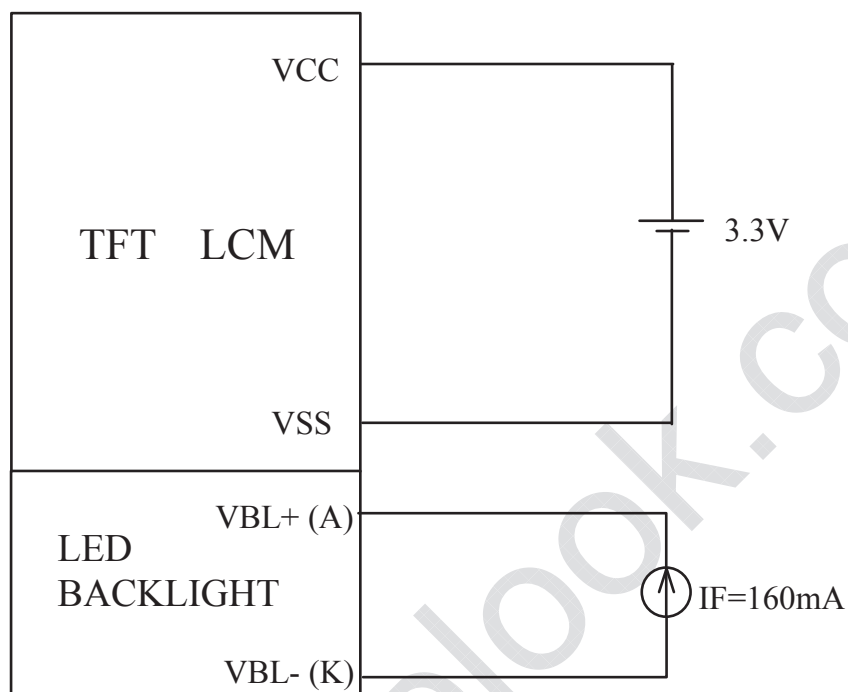

EMERGING DISPLAY  
TECHNOLOGIES CORPORATION

MODEL NO .

E T 0 7 0 0 0 1 D M 6

VERSION

6

PAGE

15

## 12 . INSPECTION CRITERION

## 12.1 APPLICATION

This inspection standard is to be applied to the LCD module delivered from EMERGING DISPLAY TECHNOLOGIES CORP.( E.D.T ) to customers

## 12.2 INSPECTION CONDITIONS

12.2.1 (1)Observation Distance : 35cm±5cm

(2)View Angle :

Non-operation Condition : ±5°(perpendicular to LCD panel surface)

Operation Condition : ±45° (perpendicular to LCD panel surface)

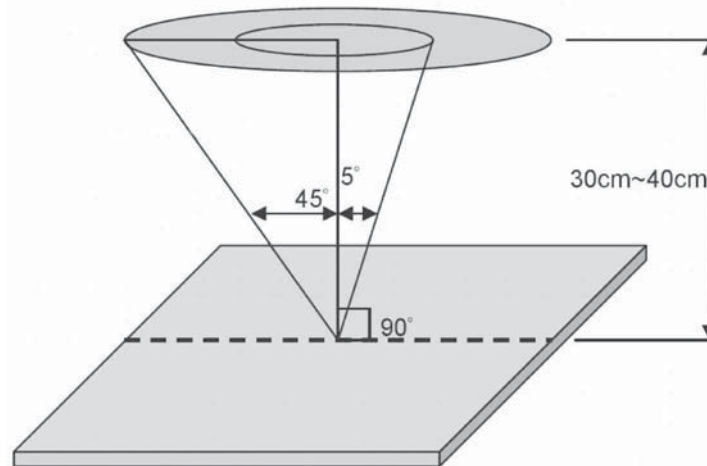

## 12.2.2 Environment Conditions :

Ambient Temperature		20°C~25°C
Ambient Humidity		65±20%RH
Ambient Illumination	Cosmetic Inspection	More than 600Lux
	Functional Inspection	300~500 Lux

## 12.2.3 Inspection lot

Quantity per delivery lot for each model

## 12.2.4 Inspection method

A sampling inspection shall be made according to the following provisions to judge The acceptability

(a)Applicable standard : MIL-STD-105E

Normal inspection , single sampling

Level II

(b)AQL : Major defect : AQL 0.65

Minor defect : AQL 1.0

EMERGING DISPLAY  
TECHNOLOGIES CORPORATION

MODEL NO .

E T 0 7 0 0 0 1 D M 6

VERSION

6

PAGE

16

## 12.3 INSPECTION STANDARDS

## 12.3.1 VISUAL DEFECTS CLASSIFICATION

TYPE OF DEFECT	INSPECTION ITEM	DEFECT FEATURE	AQL
MAJOR DEFECT	1.DISPLAY ON	<ul style="list-style-type: none"> <li>• DEFECT TO MISS SPECIFIED DISPLAY FUNCTION, FOR ALL AND SPECIFIED DOTS</li> <li>EX: DISCONNECTION, SHORT CIRCUIT ETC</li> </ul>	0.65
	2.BACKLIGHT	<ul style="list-style-type: none"> <li>• NO LIGHT</li> <li>• FLICKERING AND OTHER ABNORMAL ILLUMINATION</li> </ul>	
	3.DIMENSIONS	<ul style="list-style-type: none"> <li>• SUBJECT TO INDIVIDUAL ACCEPTANCE SPECIFICATIONS</li> </ul>	
MINOR DEFECT	1.DISPLAY ZONE	<ul style="list-style-type: none"> <li>• BLACK/WHITE SPOT</li> <li>• BUBBLES ON POLARIZER</li> <li>• NEWTON RING</li> <li>• BLACK/WHITE LINE</li> <li>• SCRATCH</li> <li>• CONTAMINATION</li> <li>• LEVER COLOR SPREAD</li> </ul>	1.0
	2.BEZEL ZONE	<ul style="list-style-type: none"> <li>• STAINS</li> <li>• SCRATCHES</li> <li>• FOREIGN MATTER</li> </ul>	
	3.SOLDERING	<ul style="list-style-type: none"> <li>• INSUFFICIENT SOLDER</li> <li>• SOLDERED IN INCORRECT POSITION</li> <li>• CONVEX SOLDERING SPOT</li> <li>• SOLDER BALLS</li> <li>• SOLDER SCRAPS</li> </ul>	
	4.DISPLAY ON (ALL ON)	<ul style="list-style-type: none"> <li>• LIGHT LINE</li> </ul>	

EMERGING DISPLAY  
TECHNOLOGIES CORPORATION

MODEL NO .

ET070001DM6

VERSION

6

PAGE

17

## 12.3.2 MODULE DEFECTS CALSSIFICATION

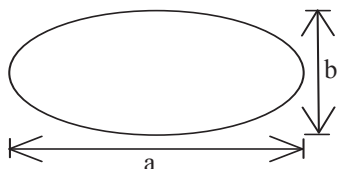
NO.	ITEM	CRITERIA												
1.	DISPLAY ON INSPECTION	(1)INCORRECT PATTERN (2)MISSING SEGMENT (3)DIM SEGMENT (4)OPERATING VOLTAGE BEYOND SPEC												
2.	OVERALL DIMENSIONS	(1)OVERALL DIMENSION BEYOND SPEC												
3.	DOT DEFECT	(1) INSPECTION PATTERN: FULL WHITE, FULL BLACK, RED, GREEN AND BLUE SCREENS. (2) <table border="1"> <thead> <tr> <th>ITEMS</th> <th>ACCEPTABLE COUNT</th> </tr> </thead> <tbody> <tr> <td>BRIGHT DOT</td> <td><math>N \leq 3</math></td> </tr> <tr> <td>DARK DOT</td> <td><math>N \leq 5</math></td> </tr> <tr> <td>TOAL BRIGHT AND DARK DOTS</td> <td><math>N \leq 5</math></td> </tr> </tbody> </table> <p>NOTE :</p> <p>1. THE DEFINITION OF DOT : THE SIZE OF A DEFECTIVE DOT OVER 1/2 OF WHOLE DOT IS REGARDED AS ONE DEFECTUVE DOT.</p> <p>2. BRIGHT DOT : DOTS APPEAR BRIGHT AND UNCHANGED IN SIZE IN WHICH LCD PANEL IS DISPLAYING UNDER BLACK PATTERN.</p> <p>3. DARK DOT : DOTS APPEAR DARK AND UNCHANGED IN SIZE IN WHICH LCD PANEL IS DISPLAYING UNDER PURE RED, GREEN, BLUE PICTURE.</p>	ITEMS	ACCEPTABLE COUNT	BRIGHT DOT	$N \leq 3$	DARK DOT	$N \leq 5$	TOAL BRIGHT AND DARK DOTS	$N \leq 5$				
ITEMS	ACCEPTABLE COUNT													
BRIGHT DOT	$N \leq 3$													
DARK DOT	$N \leq 5$													
TOAL BRIGHT AND DARK DOTS	$N \leq 5$													
4.	FOREIGN BLACK/WHITE/ BRIGHT LINE/ SCRATCH OF VIEWING AREA	<table border="1"> <thead> <tr> <th>LENGTH : L</th> <th>WIDTH : W</th> <th>PERMISSIBLE NO.</th> </tr> </thead> <tbody> <tr> <td><math>L \leq 0.3</math></td> <td><math>W \leq 0.05</math></td> <td>IGNORE</td> </tr> <tr> <td><math>0.3 &lt; L \leq 2.5</math></td> <td><math>0.05 &lt; W \leq 0.1</math></td> <td>4</td> </tr> <tr> <td><math>2.5 &lt; L</math></td> <td><math>0.1 &lt; W</math></td> <td>NONE</td> </tr> </tbody> </table> <p>WIDTH : W mm, LENGH : L mm</p>	LENGTH : L	WIDTH : W	PERMISSIBLE NO.	$L \leq 0.3$	$W \leq 0.05$	IGNORE	$0.3 < L \leq 2.5$	$0.05 < W \leq 0.1$	4	$2.5 < L$	$0.1 < W$	NONE
LENGTH : L	WIDTH : W	PERMISSIBLE NO.												
$L \leq 0.3$	$W \leq 0.05$	IGNORE												
$0.3 < L \leq 2.5$	$0.05 < W \leq 0.1$	4												
$2.5 < L$	$0.1 < W$	NONE												
5.	FOREIGN MATTER \ BLACK SPOTS \ WHITE SPOTS \ DENT (INCLUDING LIGHT LEAKAGE DUE TO POLARIZING PLATES PINHOLES, ETC.)	<table border="1"> <thead> <tr> <th>AVERAGE DIAMETER (mm): D</th> <th>NUMBER OF PIECES PERMITTED</th> </tr> </thead> <tbody> <tr> <td><math>D \leq 0.15</math></td> <td>IGNORE</td> </tr> <tr> <td><math>0.15 &lt; D \leq 0.5</math></td> <td>4</td> </tr> <tr> <td><math>0.5 &lt; D</math></td> <td>NONE</td> </tr> </tbody> </table> <p>NOTE : DIAMETER <math>D=(a+b)/2</math></p> 	AVERAGE DIAMETER (mm): D	NUMBER OF PIECES PERMITTED	$D \leq 0.15$	IGNORE	$0.15 < D \leq 0.5$	4	$0.5 < D$	NONE				
AVERAGE DIAMETER (mm): D	NUMBER OF PIECES PERMITTED													
$D \leq 0.15$	IGNORE													
$0.15 < D \leq 0.5$	4													
$0.5 < D$	NONE													

EMERGING DISPLAY  
TECHNOLOGIES CORPORATION

MODEL NO .

E T 0 7 0 0 0 1 D M 6

VERSION

6

PAGE

18

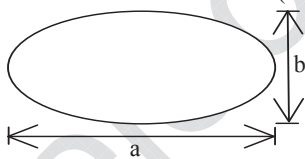
NO.	ITEM	CRITERIA		
			AVERAGE DIAMETER (mm) : D	NUMBER OF PIECES PERMITTED
6.	BUBBLES OF POLARIZER /DIRT/CF FAIL /SURFACE STAINS	BUBBLE ON THE POLARIZER	$D \leq 0.25$	IGNORE
			$0.25 < D \leq 0.5$	$N \leq 5$
			$0.5 < D$	NOTE
		SURFACE STATUS	$D < 0.1 \text{ mm}$	IGNORE
			$0.1 < D \leq 0.3 \text{ mm}$	$N \leq 3$
		CF FAIL / SPOT	$D < 0.1 \text{ mm}$	IGNORE
$0.1 < D \leq 0.3 \text{ mm}$	$N \leq 3$			
		NOTE : (1)POLARIZER BUBBLE IS DEFINED AS THE BUBBLE APPEARS ON ACTIVE DISPLAY AREA. THE DEFECT OF POLARIZER BUBBLE SHALL BE IGNORED IF THE POLARIZER BUBBLE APPEARS ON THE OUTSIDE OF ACTIVE DISPLAY AREA. (2)THE EXTRANEIOUS SUBSTANCE IS DEFINED AS IT CAN BE OBSERVED WHEN THE MODULE IS POWER ON. (3)THE DEFINITION OF AVERAGE DIAMETER, D IS DEFINED AS FOLLOWING. AVERAGE DIAMETER (D)=(a+b)/2 		
7.	LINE DEFECT ON DISPLAY	OBVIOUS VERTICAL OR HORIZONTAL LINE DEFECT IS NOT ALLOW		
8.	MURA ON DISPLAY	IT'S OK IF MURA IS SLIGHT VISIBLE THROUG 6% ND FILTER		
9.	UNEVEN COLOR SPREAD, COLORATION	(1)TO BE DETERMINED BASED UPON THE STANDARD SAMPLE.		
10.	BEZEL APPEARANCE	(1)BEZEL MAY NOT HAVE RUST, BE DEFORMED OR HAVE FINGER PRINTS STAINS OF OTHER CONTAMINATION. (2)BEZEL MUST COMPLY WITH JOB SPECIFICATIONS.		
11	PCB	(1)THERE MAY NOT BE MORE THAN 2mm OF SEALANT OUTSIDE THE SEAL AREA ON THE PCB, AND THERE SHOULD BE NO MORE THAN THREE PLACES. (2)NO OXIDATION OR CONTAMINATION PCB TERMINALS. (3)PARTS ON PCB MUST BE THE SAME AS ON THE PRODUCTION CHARACTERISTIC CHART. THERE SHOULD BE NO WRONG PARTS, MISSING PARTS OR EXCESS PARTS. (4)THE JUMPER ON THE PCB SHOULD CONFORM TO THE PRODUCT CHARACTERISTIC CHART. (5)IF SOLDER GETS ON BEZEL TAB PADS, LED PAD, ZEBRA PAD OR SCREW HOLD PAD, MAKE SURE IT IS SMOOTHED DOWN.		

EMERGING DISPLAY  
TECHNOLOGIES CORPORATION

MODEL NO.	VERSION	PAGE
ET070001DM6	6	19

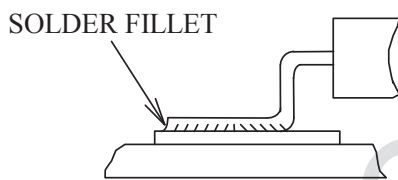
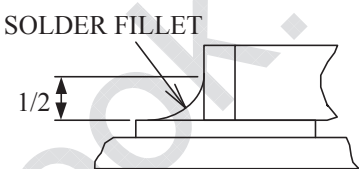
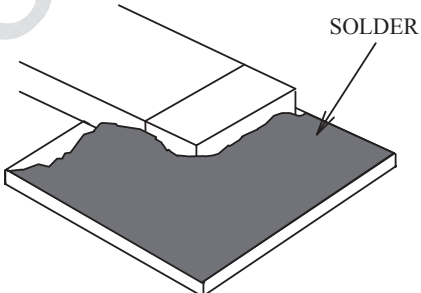
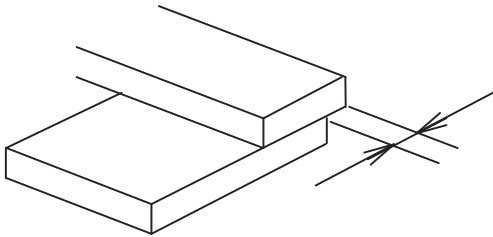
NO.	ITEM	CRITERIA
12.	SOLDERING	<p>(1)NO SOLDERING FOUND ON THE SPECIFIED PLACE (2)INSUFFICIENT SOLDER</p> <p>(a)LSI, IC A POOR WETTING OF SOLDER IS BETWEEN LOWER BEND OR "HEEL" OF LEAD AND PAD</p>  <p>(b)CHIP COMPONENT · SOLDER IS LESS THAN 50% OF SIDES AND FRONT FACE WETTING</p>  <ul style="list-style-type: none"> <li>• SOLDER WETS 3 SIDES OF TERMINAL, BUT LESS THAN 25% OF SIDES AND FRONT SURFACE AREA ARE COVERED</li> </ul>  <p>(3)PARTS ALIGMENT (a)LSI, IC LEAD WIDTH IS MORE THAN 50% BEYOND PAD OUTLINE</p> 

EMERGING DISPLAY  
TECHNOLOGIES CORPORATION

MODEL NO .

E T 0 7 0 0 0 1 D M 6

VERSION

6

PAGE

20

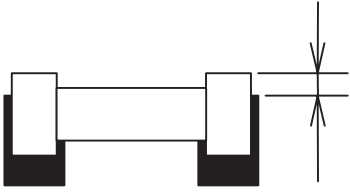
NO.	ITEM	CRITERIA
12.	SOLDERING	<p>(b)CHIP COMPONENT COMPONENT IS OFF CENTER, AND MORE THAN 50% OF THE LEADS IS OFF THE PAD OUTLINE</p>  <p>(4)NO UNMELTED SOLDER PASTE MAY BE PRESENT ON THE PCB.  (5)NO COLD SOLDER JOINTS, MISSING SOLDER CONNECTIONS, OXIDATION OR ICICLE.  (6)NO RESIDUE OR SOLDER BALLS ON PCB.  (7)NO SHORT CIRCUITS IN COMPONENTS ON PCB.</p>
13.	BACKLIGHT	<p>(1)NO LIGHT  (2)FLICKERING AND OTHER ABNORMAL ILLUMINATION  (3)SPOTS OR SCRATCHES THAT APPEAR WHEN LIT MUST BE JUDGED USING LCD SPOT, LINES AND CONTAMINATION STANDARDS.  (4)BACKLIGHT DOESN'T LIGHT OR COLOR IS WRONG.</p>
14.	GENERAL APPEARANCE	<p>(1)NO OXIDATION, CONTAMINATION, CURVES OR, BENDS ON INTERFACE PIN (OLB) OF TCP.  (2)NO CRACKS ON INTERFACE PIN (OLB) OF TCP.  (3)NO CONTAMINATION, SOLDER RESIDUE OR SOLDER BALLS ON PRODUCT.  (4)THE IC ON THE TCP MAY NOT BE DAMAGED, CIRCUITS.  (5)THE UPPERMOST EDGE OF THE PROTECTIVE STRIP ON THE INTERFACE PIN MUST BE PRESENT OR LOOK AS IF IT CAUSE THE INTERFACE PIN TO SEVER.  (6)THE RESIDUAL ROSIN OR TIN OIL OF SOLDERING (COMPONENT OR CHIP COMPONENT) IS NOT BURNED INTO BROWN OR BLACK COLOR.  (7)SEALANT ON TOP OF THE ITO CIRCUIT HAS NOT HARDENED.  (8)PIN TYPE MUST MATCH TYPE IN SPECIFICATION SHEET.  (9)LCD PIN LOOSE OR MISSING PINS.  (10)PRODUCT PACKAGING MUST THE SAME AS SPECIFIED ON PACKAGING SPECIFICATION SHEET.  (11)PRODUCT DIMENSION AND STRUCTURE MUST CONFORM TO PRODUCT SPECIFICATION SHEET.  (12)THE APPEARANCE OF HEAT SEAL SHOULD NOT ADMIT ANY DIRT AND BREAK.</p>

EMERGING DISPLAY TECHNOLOGIES CORPORATION

MODEL NO.	VERSION	PAGE
ET070001DM6	6	21

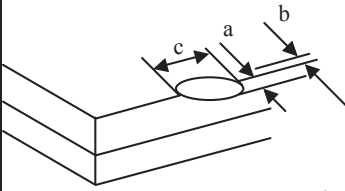
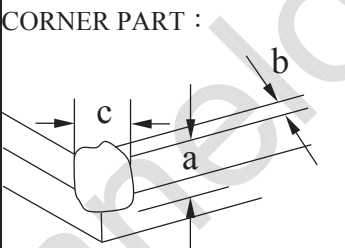
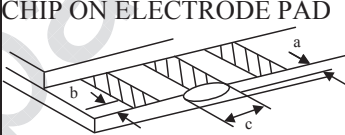
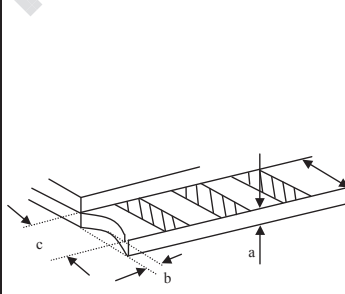
NO.	ITEM	CRITERIA									
15.	CRACKED GLASS	<p>THE LCD WITH EXTENSIVE CRACK IS NOT ACCEPTABLE</p> <p>GENERAL GLASS CHIP :</p>  <table border="1"> <thead> <tr> <th>a</th> <th>b</th> <th>c</th> </tr> </thead> <tbody> <tr> <td><math>\leq t/2</math></td> <td>&lt; VIEWING AREA</td> <td><math>\leq 1/8X</math></td> </tr> <tr> <td><math>t/2 &gt;, \leq 2t</math></td> <td><math>\leq W/2</math></td> <td><math>\leq 1/8X</math></td> </tr> </tbody> </table> <p>*W=DISTANCE BETWEEN SEALANT AREA AND LCD PANEL EDGE X = LCD SIDE LENGTH t = GLASS THICKNESS</p>	a	b	c	$\leq t/2$	< VIEWING AREA	$\leq 1/8X$	$t/2 >, \leq 2t$	$\leq W/2$	$\leq 1/8X$
		a	b	c							
		$\leq t/2$	< VIEWING AREA	$\leq 1/8X$							
		$t/2 >, \leq 2t$	$\leq W/2$	$\leq 1/8X$							
<p>CORNER PART :</p>  <table border="1"> <thead> <tr> <th>a</th> <th>b</th> <th>c</th> </tr> </thead> <tbody> <tr> <td><math>\leq t/2</math></td> <td>&lt; VIEWING AREA</td> <td><math>\leq 1/8X</math></td> </tr> <tr> <td><math>&gt; t/2, \leq 2t</math></td> <td><math>\leq W/2</math></td> <td><math>\leq 1/8X</math></td> </tr> </tbody> </table> <p>*W=DISTANCE BETWEEN SEALANT AREA AND LCD PANEL EDGE X = LCD SIDE LENGTH t = GLASS THICKNESS</p>	a	b	c	$\leq t/2$	< VIEWING AREA	$\leq 1/8X$	$> t/2, \leq 2t$	$\leq W/2$	$\leq 1/8X$		
a	b	c									
$\leq t/2$	< VIEWING AREA	$\leq 1/8X$									
$> t/2, \leq 2t$	$\leq W/2$	$\leq 1/8X$									
<p>CHIP ON ELECTRODE PAD</p>  <table border="1"> <thead> <tr> <th>a</th> <th>b</th> <th>c</th> </tr> </thead> <tbody> <tr> <td><math>\leq t</math></td> <td><math>\leq 0.5\text{mm}</math></td> <td><math>\leq 1/8X</math></td> </tr> </tbody> </table> <p>*X=LCD SIDE WIDTH t=GLASS THICKNESS</p>	a	b	c	$\leq t$	$\leq 0.5\text{mm}$	$\leq 1/8X$					
a	b	c									
$\leq t$	$\leq 0.5\text{mm}$	$\leq 1/8X$									
 <table border="1"> <thead> <tr> <th>a</th> <th>b</th> <th>c</th> </tr> </thead> <tbody> <tr> <td><math>\leq t</math></td> <td><math>\leq 1/8X</math></td> <td><math>\leq L</math></td> </tr> </tbody> </table> <p>*X=LCD SIDE WIDTH t = GLASS THICKNESS L=ELECTRODE PAD LENGTH ①IF GLASS CHIPPING THE ITO TERMINAL, OVER 2/3 OF THE ITO MUST REMAIN AND BE, INSPECTED ACCORDING TO ELECTRODE TERMINAL SPECIFICATIONS ②IF THE PRODUCT WILL BE HEAT SEALED BY THE CUSTOMER, THE ALIGNMENT MARK MUST NOT BE DAMAGED</p>	a	b	c	$\leq t$	$\leq 1/8X$	$\leq L$					
a	b	c									
$\leq t$	$\leq 1/8X$	$\leq L$									



EMERGING DISPLAY  
TECHNOLOGIES CORPORATION

MODEL NO .

ET070001DM6

VERSION

6

PAGE

22

## 12.4 RELIABILITY TEST

## 12.4.1 STANDARD SPECIFICATIONS FOR RELIABILITY OF LCD MODULE

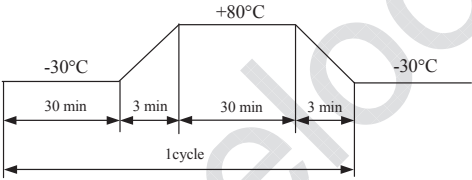
NO	ITEM	DESCRIPTION
1	HIGH TEMPERATURE OPERATION	THE SAMPLE SHOULD BE ALLOWED TO STAND AT +70°C FOR 240 hrs
2	LOW TEMPERATURE OPERATION	THE SAMPLE SHOULD BE ALLOWED TO STAND AT -20°C FOR 240 hrs
3	HIGH TEMPERATURE STORAGE	THE SAMPLE SHOULD BE ALLOWED TO STAND AT +80°C FOR 240 hrs
4	LOW TEMPERATURE STORAGE	THE SAMPLE SHOULD BE ALLOWED TO STAND AT -30°C FOR 240 hrs
5	HIGH TEMP / HUMIDITY TEST (STORAGE)	THE SAMPLE SHOULD BE ALLOWED TO STAND AT 60°C, 90% RH 240 hrs
6	THERMAL SHOCK (NOT OPERATED)	THE SAMPLE SHOULD BE ALLOWED TO STAND THE FOLLOWING 10 CYCLES OF OPERATION: 
7	ESD (ELECTROSTATIC DISCHARGE) (NOT OPERATED)	AIR DISCHARGE ± 12KV CONTACT DISCHARGE ± 8KV ACCORDING TO IEC-61000-4-2

NOTE (1) : THE TEST SAMPLES HAVE RECOVERY TIME FOR 2 HOURS AT ROOM TEMPERATURE BEFORE THE FUNCTION CHECK. IN THE STANDARD CONDITIONS, THERE IS NO DISPLAY FUNCTIONING ISSUE OCCURRED.

## 12.5 TESTING CONDITIONS AND INSPECTION CRITERIA

FOR THE FINAL TEST THE TESTING SAMPLE MUST BE STORED AT ROOM TEMPERATURE FOR 24 HOURS, AFTER THE TESTS LISTED IN TABLE 12.5, STANDARD SPECIFICATIONS FOR RELIABILITY HAVE BEEN EXECUTED IN ORDER TO ENSURE STABILITY.

NO	ITEM	TEST MODEL	INSPECTION CRITERIA
1	CURRENT CONSUMPTION	REFER TO SPECIFICATION	THE CURRENT CONSUMPTION SHOULD CONFORM TO THE PRODUCT SPECIFICATION.
2	CONTRAST	REFER TO SPECIFICATION	AFTER THE TESTS HAVE BEEN EXECUTED, THE CONTRAST MUST BE LARGER THAN HALF OF ITS INITIAL VALUE PRIOR TO THE TESTS.
3	APPEARANCE	VISUAL INSPECTION	DEFECT FREE

## 12.6 OPERATION

- 12.6.1 DO NOT CONNECT OR DISCONNECT MODULES TO OR FROM THE MAIN SYSTEM WHILE POWER IS BEING SUPPLIED .
- 12.6.2 USE THE MODULE WITHIN SPECIFIED TEMPERATURE ; LOWER TEMPERATURE CAUSES THE RETARDATION OF BLINKING SPEED OF THE DISPLAY ; HIGHER TEMPERATURE MAKES OVERALL DISPLAY DISCOLOR. WHEN THE TEMPERATURE RETURNS TO NORMALITY, THE DISPLAY WILL OPERATE NORMALLY .
- 12.6.3 ADJUST THE LC DRIVING VOLTAGE TO OBTAIN THE OPTIMUM CONTRAST.
- 12.6.4 POWER ON SEQUENCE INPUT SIGNALS SHOULD NOT BE SUPPLIED TO LCD MODULE BEFORE POWER SUPPLY VOLTAGE IS APPLIED AND REACHES THE SPECIFIED VALUE .  
IF ABOVE SEQUENCE IS NOT FOLLOWED , CMOS LSIS OF LCD MODULES MAY BE DAMAGED DUE TO LATCH - UP PROBLEM .
- 12.6.5 Not allowed to inflict any external stress and to cause any mechanical interference on the bending area of FPC during the tail bending backwards!  
Do NOT stress FPC and IC on the Module!

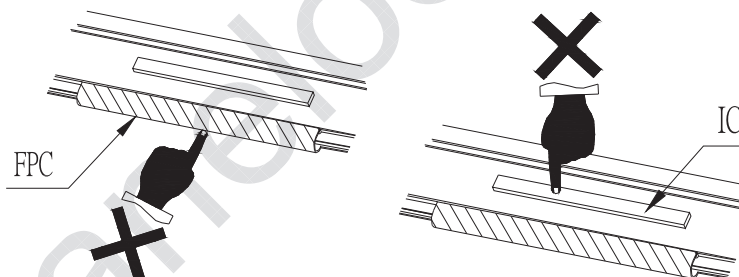

EMERGING DISPLAY  
TECHNOLOGIES CORPORATION

MODEL NO .

E T 0 7 0 0 0 1 D M 6

VERSION

6

PAGE

24

## 12.7 NOTICE

- 12.7.1 USE A GROUNDED SOLDERING IRON WHEN SOLDERING CONNECTOR I/O TERMINALS . FOR SOLDERING OR REPAIRING, TAKE PRECAUTION AGAINST THE TEMPERATURE OF THE SOLDERING IRON AND THE SOLDERING TIME TO PREVENT PEELING OFF THE THROUGH-HOLE-PAD .
- 12.7.2 DO NOT DISASSEMBLE . EDT SHALL NOT BE HELD RESPONSIBLE IF THE MODULE IS DISASSEMBLED AND UPON THE REASSEMBLY THE MODULE FAILED .
- 12.7.3 DO NOT CHARGE STATIC ELECTRICITY , AS THE CIRCUIT OF THIS MODULE CONTAINS CMOS LSIS. A WORKMAN'S BODY SHOULD ALWAYS BE STATIC-PROTECTED BY USE OF AN ESD STRAP. WORKING CLOTHES FOR SUCH PERSONNEL SHOULD BE OF STATIC-PROTECTED MATERIAL .
- 12.7.4 ALWAYS GROUND THE ELECTRICALLY-POWERED DRIVER BEFORE USING IT TO INSTALL THE LCD MODULE. WHILE CLEANING THE WORK STATION BY VACUUM CLEANER, DO NOT BRING THE SUCKING MOUTH NEAR THE MODULE ; STATIC ELECTRICITY OF THE ELECTRICALLY-POWERED DRIVER OR THE VACUUM CLEANER MAY DESTROY THE MODULE .
- 12.7.5 DON'T GIVE EXTERNAL SHOCK.
- 12.7.6 DON'T APPLY EXCESSIVE FORCE ON THE SURFACE.
- 12.7.7 LIQUID IN LCD IS HAZARDOUS SUBSTANCE. MUST NOT LICK AND SWALLOW.  
WHEN THE LIQUID IS ATTACH TO YOUR, SKIN, CLOTH ETC.  
WASH IT OUT THOROUGHLY AND IMMEDIATELY.
- 12.7.8 DON'T OPERATE IT ABOVE THE ABSOLUTE MAXIMUM RATING.
- 12.7.9 STORAGE IN A CLEAN ENVIRONMENT, FREE FROM DUST, ACTIVE GAS, AND SOLVENT.
- 12.7.10 STORE WITHOUT ANY PHYSICAL LOAD.
- 12.7.11 REWIRING: NO MORE THAN 3 TIMES.