

SHARP®

POCKET DISK DRIVE
TASCHENDISKETTENLAUF WERK
L'UNITE DE MICRO-DISQUE

MODEL
MODELL
MODELE

CE-140F

OPERATION MANUAL BEDIENUNGSANLEITUNG MODE D'EMPLOI

ENGLISH Page 1
DEUTSCH Seite 39
FRANÇAIS Page 49

WELCOME

Thank you for purchasing the SHARP CE-140F Pocket Disk Drive. Please read this operation manual carefully so you can use the disk drive correctly.

Keep this manual with the machine. It will help you use the disk drive.

NOTE

Information in this manual is subject to change without notice and does not represent a commitment on the part of the SHARP CORPORATION.

CONTENTS

	Page
PRECAUTIONS	3
FEATURES OF THE POCKET DISK DRIVE	4
COMPATIBLE POCKET COMPUTERS	4
NOMENCLATURE AND FUNCTIONS	4
REPLACING DRY CELLS	6
CONNECTION	7
POWER ON SEQUENCE	7
NOTES ON USE	7
DISK CONSTRUCTION AND DISC HANDLING	8
(1) Disk Construction	8
(2) Write Inhibition (Write Protection)	8
INSERTING AND REMOVING A DISK	9
(1) Inserting a Disk	9
(2) Removing a Disk	9
USING A POCKET DISK	10
INSTRUCTION SET	15
CHAIN	16
CLOSE	17
COPY	18
DSKF	19
EOF	20
FILES	21
INPUT#	22
INIT	24
KILL	25
LFILES	26
LOAD	27
LOC	28
LOF	29
MERGE	30
NAME	31
OPEN	32
PRINT#	33
SAVE	35
SET	36
SPECIFICATIONS	37

PRECAUTIONS

Do not leave the pocket disk drive or pocket disk in a parked car. Do not leave it in a hot, sunny place or near a heater. If these precautions are ignored, the pocket disk drive or pocket disk may be damaged.

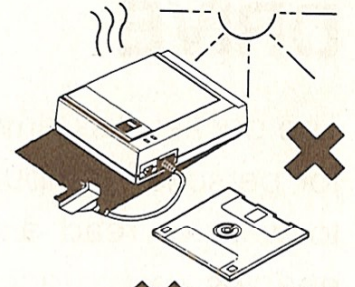

Do not use or place magnetic sources such as magnets or television sets near the pocket disk drive or pocket disk. If this precaution is ignored, pocket disk data may be destroyed or the pocket disk drive may malfunction.

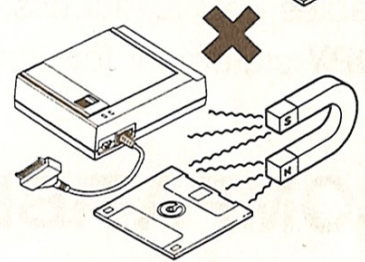

Do not use or store the pocket disk drive or pocket disk in a dusty or humid environment. If this precaution is ignored, the pocket disk drive or pocket disk may be damaged.

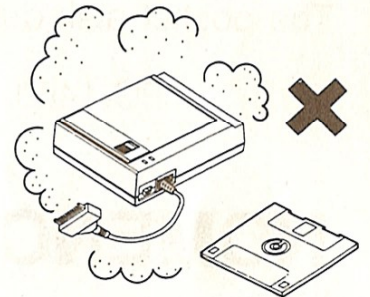

Do not open the disk shutter. This shutter prevents the magnetized surface being touched. In addition, do not press the disk shutter or hub.

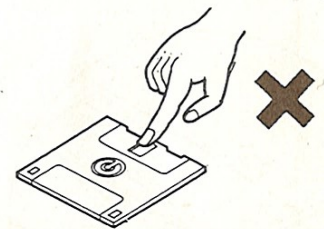

Do not use a damp cloth or volatile liquid (thinner or benzine) to clean the pocket disk drive or pocket disk. Use a dry, soft cloth.

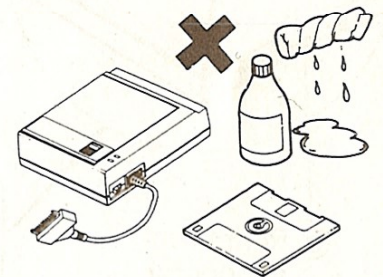

Store the pocket disk in a vinyl wrapper.



Do not place the pocket disk in an area where smoking and/or drinking is permitted.

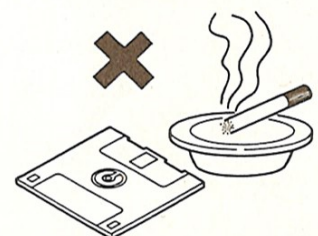

Keep the pocket disk clean. Dirty pocket disks may cause errors.

FEATURES OF THE POCKET DISK DRIVE

The pocket disk drive is similar to floppy disk drives that are generally available for personal computers. Compared to cassette tape recorders, it enables you to write or read a program or data more quickly and easily. In addition, it enables you to access a data storage location more quickly and to use the **COPY** statement for simpler data backup.

COMPATIBLE POCKET COMPUTERS

The pocket disk drive can be connected to the following computers:

PC-1460, PC-1403, PC-1425 and PC-1360 (January, 1987)

NOMENCLATURE AND FUNCTIONS

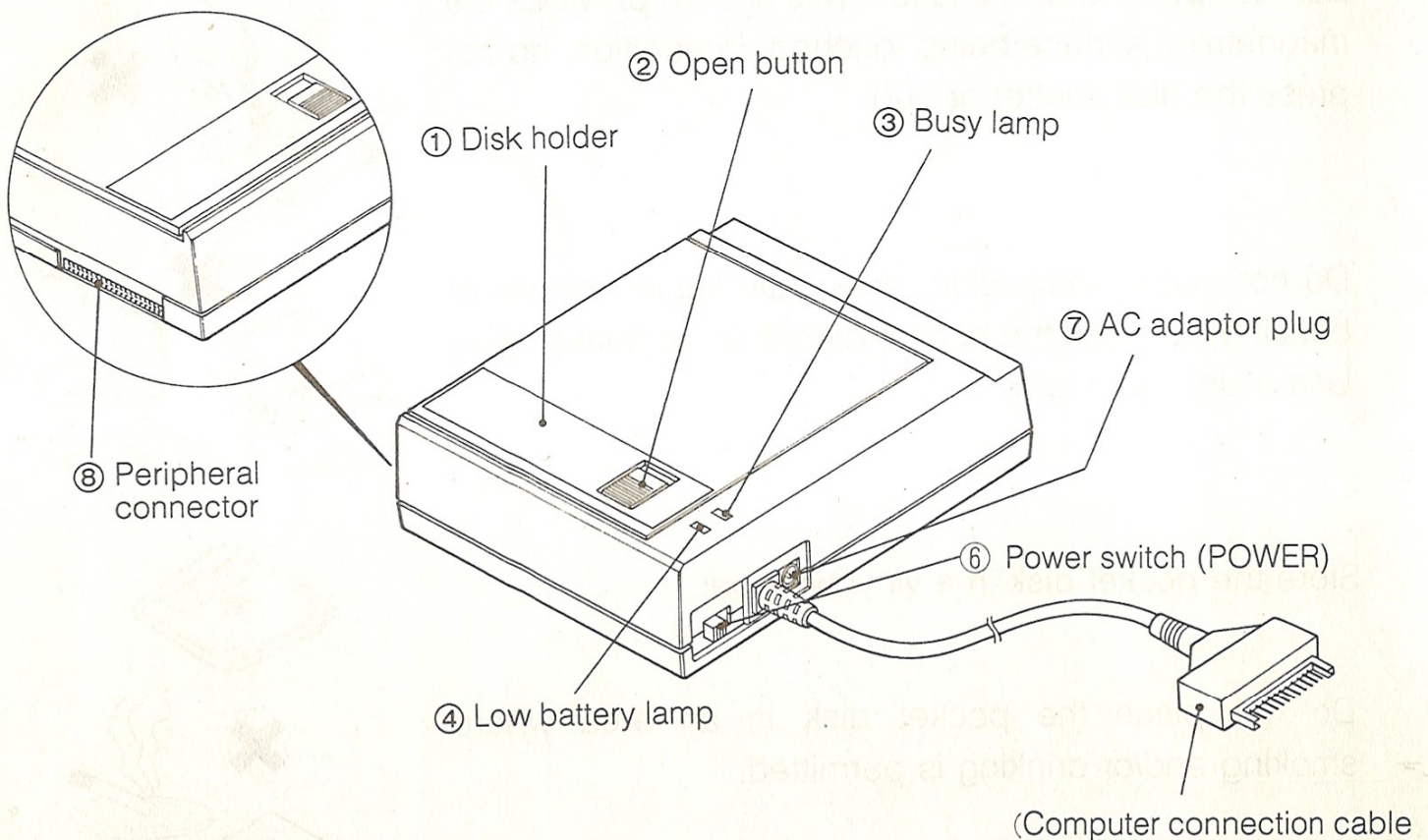

(1) Disk Holder

This holds the pocket disk (simply called a disk). Slide the open button in the direction of the arrow (▲) to open the disk holder, then insert a disk into the holder. See page 9.

(2) Open Button (OPEN)

Slide this button in the direction of the arrow (▲) to open the disk holder and insert the disk.

(3) Busy Lamp

This lamp is lit while the disk is being accessed. Namely, it is lit when data is being written to or read from the disk or when data is being transferred to or from the computer.

Caution: Do not touch the open button while this lamp is lit. If an attempt is made to open the disk holder during an access operation, the disk may be damaged or data destroyed. This lamp is also lit when a printer-related instruction is executed. It does not indicate an error.

(4) Low Battery Lamp

This lamp is lit when the internal battery voltage has fallen below the minimum limit. Set the power to OFF and replace the dry cells. Alternatively, connect AC adaptor (EA-160), which is commercially available. If an attempt is made to connect the AC adaptor when the power switch is set to ON data destruction or disk damage may occur.

(5) Computer Connection Cable

This cable is fitted with a connection. Use this cable to connect the pocket disk drive to the computer. The connector is capped for protection during shipping. Remove the cap before connection.

(6) Power Switch (POWER)

Set this switch to ON, and the pocket disk drive will be powered.
Set this switch to OFF to turn off the pocket disk drive.

(7) AC Adaptor Plug

This plug is used to connect the AC adaptor (option).

(8) Peripheral Connector

This connector is used to connect the CE-126P printer.

REPLACING DRY CELLS

The pocket disk drive operates from internal dry cells or an AC adaptor. Insert dry cells before attempting to use the pocket disk drive. When the low battery lamp lights; replace the dry cells as follows:

- (1) Set all of the power switches of the computer, pocket disk drive, and peripherals, to OFF.
- (2) Loosen the battery cover screw, and lift off the battery cover.

When replacing dry cells, remove all the exhausted cells.

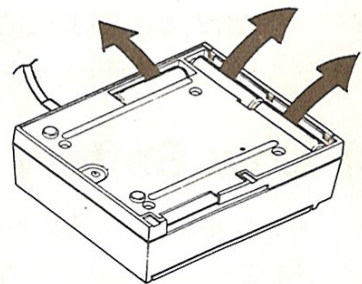
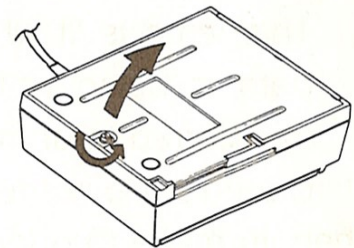

- (3) Insert five new dry cells. Do not attempt use old and new dry cells together.

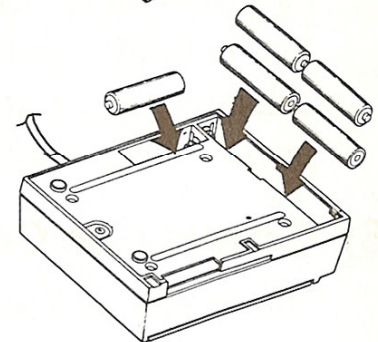

- (4) Insert the tabs of the battery cover, lower it into place, then tighten the screw.

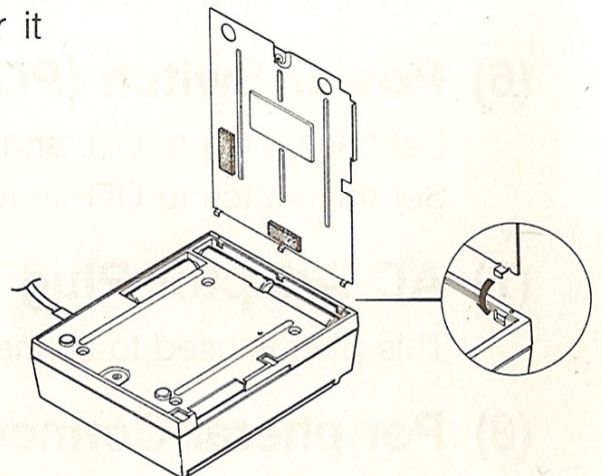

CONNECTION

Connect the pocket disk drive to the computer using the dedicated cable only.

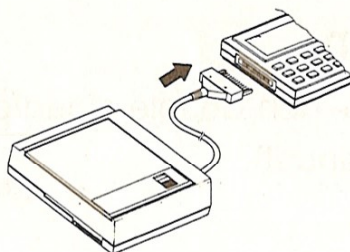

POWER ON SEQUENCE

The computer and pocket disk drive must be powered as follows:

- ① Set the power switch of the computer to ON.
- ② Set the power switch of the pocket disk drive to ON.

Insert the disk after the computer and pocket disk drive have been powered. When turning off the computer and pocket disk drive, perform the above operations in the reverse order. First, remove the disk, then set the power switches of the pocket disk drive and computer to OFF in that order. Do not attempt to re-power the computer or pocket disk drive until at least five seconds pass.

NOTES ON USE

Because the pocket disk drive is a precision instrument, use and store it observing the following points. Ignoring these precautions will result in the pocket disk drive being damaged.

- ① Do not turn the power on or off when a disk is in the pocket disk drive.
- ② Do not push the open button while the busy lamp is lit. Pushing this button may cause data to be deleted from the disk.
- ③ If the low battery lamp (red) lights during disk operation, turn off the power after completion of the operation, replace the dry cells, or connect the AC adaptor.
- ④ Connect the pocket disk drive as specified and use it in a safe, vibration-free place.
- ⑤ Connect or disconnect all devices, including the pocket disk drive, only after setting their power switches to OFF.
- ⑥ Do not jolt or put weight on the pocket disk drive. Especially, avoid putting heavy objects on the top cover of the disk drive.
- ⑦ Remove the disk and dry cells when the pocket disk drive is not to be used for a long time.

DISK CONSTRUCTION AND DISK HANDLING

(1) Disk Construction

The pocket disk drive uses 2.5-inch double-sided/double density pocket disks (simply called a disk in this manual).

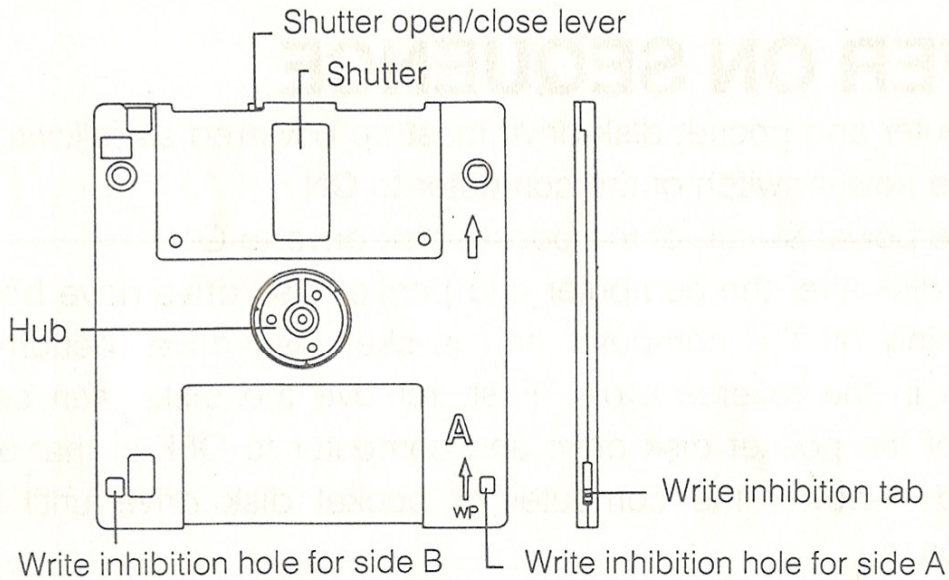

Use the provided disk or CE-1650F disks, which are generally available. Other disks may damage the pocket disk drive.

- Disks must be formatted for use in the pocket disk drive. Format a new disk before using it. Do this using the **INIT** command.

- ◆ When purchasing disks from a dealer of our products in your area, specify CE-1650F disks for CE-140F.

(2) Write Inhibition (Write Protection)

- Slide the write inhibition tab in the direction of the arrow (as shown in Figure 1) to prevent data being written or deleted. If an attempt is made to write or delete data with the tab in this position (write inhibition), it causes an error.

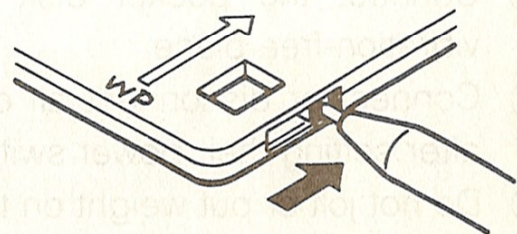

(Figure 1)

- Slide the write inhibition tab in the opposite direction (as shown in Figure 2) to set the write enable status and enable writing to, or deletion from the pocket disk.

(Figure 2)

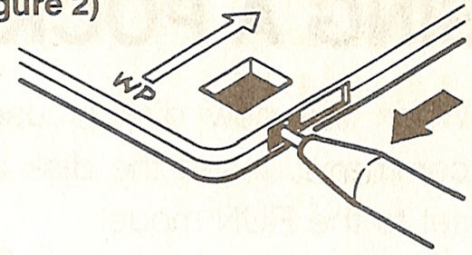

Both sides (A and B) of the pocket disk are write-inhibited individually. Check the side, then set the write inhibition status as required.

INSERTING AND REMOVING A DISK

- To insert or remove a disk, push the open button after checking that the busy lamp is not lit.

(1) Inserting a Disk

① Slide the open button in the direction of the arrow ①. The disk holder will open.

② Insert the disk into the disk holder with either side (A or B) facing up. Push it in the direction of the arrow ② until the disk locks.

③ Press the disk holder in the direction of the arrow ③ to close it. If the disk has not been pushed fully home, the disk holder cannot be closed. Do not attempt to close the disk holder forcibly. Push the disk fully home first.

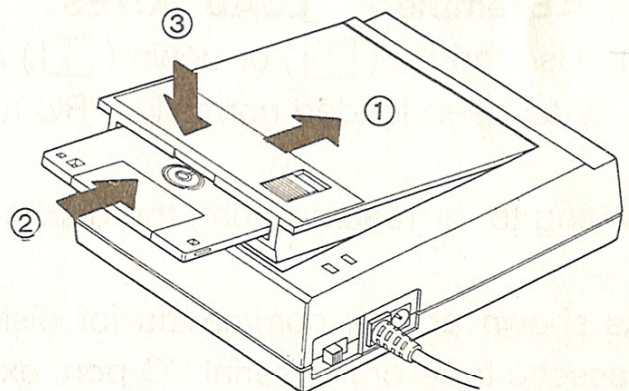

(2) Removing a Disk

Open the disk holder by sliding the open button in the direction of the arrow ① shown in the above figure. Remove the disk. The disk must be inserted into its vinyl wrapper immediately.

USING A POCKET DISK

- 1) When the new disk is used, it must first be formatted using the **INIT** command. Insert the disk after checking that it is not write-inhibited then set to the RUN mode.

<Example> **INIT "X:"**

- 2) Set the computer to the PRO mode to write a program.

<Example> **10 INPUT A**
20 PRINT A
30 END

- 3) Record the program on the disk.

<Example> **SAVE "X:TEST"**

- 4) To check that the program can be read from the disk, delete the program from the computer's internal memory.

<Example> **NEW**

- 5) Read the recorded program from the disk.

<Example> **LOAD "X:TEST"**

- 6) Use the up () or down () arrow key to check whether the program has been loaded normally (PRO mode).

Writing to, or reading from, the disk is done using the above procedures.

As shown above, commands for disk handling are similar to those used for cassette tape or the serial I/O port, except for the use of the file descriptor, file number, and wild card.

File Descriptor

A file descriptor is a name assigned for file identification. It must be specified in the following format:

"device name:file name.extension"

The device name is an identification assigned for a device. **"X"** is used for this pocket disk drive.

The file name must be specified, using up to eight alphanumeric characters. In addition, the extension must consist of a period and up to three alphanumeric characters. It indicates the file type.

If no extension is specified with the **LOAD** or **SAVE** command, the extension **".BAS"** is automatically specified.

The following characters can be used to specify the file name and extension.

Program Example:

Calculate the total and average of two math tests for five students. Assume that all input data (for the first and second test) and the values obtained (total and average) are stored on the disk. Use a disk formatted for the pocket disk drive.

<Example>

Code No.	1	2	3	4	5
Test 1	59	65	86	84	86
Test 2	56	58	74	77	93
Total	115	123	160	161	179
Average	57.5	61.5	80	80.5	89.5

} Input values

} Calculation result

<Operation>

RUN **ENTER**

1 **ENTER** Specify the use of the first or second test data.

59 **ENTER** Enter the first test data

65 **ENTER**

86 **ENTER**

84 **ENTER**

86 **ENTER**

RUN **ENTER**

2 **ENTER** Specify the use of the second test data.

56 **ENTER** Enter the second test data

58 **ENTER**

74 **ENTER**

77 **ENTER**

93 **ENTER**

DEF **A** Calculation

DEF **Z** Result display

ENTER 1 115 57.50

ENTER 2 123 61.50

ENTER 3 160 80.00

ENTER 4 161 80.50

ENTER 5 179 89.50

<Program Explanation>

- Line 10: Specifies the number of students.
- Lines 90~100: Specifies that the first test data is to be stored on the disk.
- Line 120~130: Specifies that the second test data is to be stored on the disk.
- Lines 150~160: Specifies that the first test data is to be read from the disk.
- Lines 170~180: Specifies that the second test data is to be read from the disk.
- Lines 230~240: Specifies that the total is to be stored on the disk.
- Lines 250~260: Specifies that the average is to be stored on the disk.
- Line 340: Specifies that the results to be output.

To change the number of students, line 10 (N=5) must be changed. To print the result, the **PRINT** statement in line 340 must be replaced with the **LPRINT** statement.

<Program Listing>

```
10:N=5
20:"B":INPUT "No.1=1 No
.. .2=2 "A
30:IF (A<>1)*(A<>2)
   THEN "B"
40:DIM A(N),B(N),C(N),D
   (N)
50:FOR I=1 TO N
60:INPUT "DATA=" A(I)
70:NEXT I
80:IF A=2 THEN "C"
90:OPEN "X:DATA1" FOR
   OUTPUT AS #2
100:PRINT #2,A(*)
110:CLOSE :END
120:"C":OPEN "X:DATA2"
   FOR OUTPUT AS #2
130:PRINT #2,A(*)
140:CLOSE :END
150:"A":OPEN "X:DATA1"
   FOR INPUT AS #2
160:INPUT #2,A(*)
170:OPEN "X:DATA2" FOR
   INPUT AS #3
180:INPUT #3,B(*)
190:CLOSE

200:FOR I=1 TO N
210:C(I)=A(I)+B(I):D(I)=
   C(I)/2
220:NEXT I
230:OPEN "X:DATA3" FOR
   OUTPUT AS #2
240:PRINT #2,C(*)
250:OPEN "X:DATA4" FOR
   OUTPUT AS #3
260:PRINT #3,D(*)
270:END
280:"Z":OPEN "X:DATA3"
   FOR INPUT AS #2
290:INPUT #2,C(*)
300:OPEN "X:DATA4" FOR
   INPUT AS #3
310:INPUT #3,D(*)
320:CLOSE
330:FOR I=1 TO N
340:PRINT USING "###";I;
   USING "#####";C(I);
   USING "####.##";D(I)
350:NEXT I:END
```

(PC-1460 Program Sample)

Notes:

● Data Compatibility

Data may not be read because of data incompatibility between the PC-1360 and PC-1460, PC-1403 or PC-1425, as shown below.

1. ASCII files (programs saved by **SAVE "file name",A**) can be used by all machines.
 2. Data files can be used by all machines.
 3. Intermediate files (binary files saved by **SAVE "file name"**) can be used by both the PC-1460, PC-1403 and PC-1425, but not by the PC-1360 (ERROR 9).
-
- When two disks are being used for **COPY** command execution, if the **BRK** key is pressed to interrupt the execution, turn off the power of the pocket disk drive, and turn it on again after five seconds.
 - Check whether the disk has been write-inhibited before using it.

INSTRUCTION SET

This section explains only those statements that are related to the pocket computer. See the operation manual of computer for details of the other statements.

Terminology is explained below.

Expression:	Numeric value, numeric variable, or calculation expression containing the value(s) or variable(s)
Variable:	Numeric variable containing the array element(s) or character variable
Character string:	"character" or character variable
"Character":	Character (character, numeric character, or symbol) enclosed by double quotation marks
$\left\{ \begin{array}{l} A \\ B \end{array} \right\} :$	When A and B have been braced, either A or B can be selected.
$[] :$	Items enclosed by square brackets can be omitted or repeated. When further specification is given after the right-hand bracket, a comma or a semicolon must be coded.
M:	Execution by manual operation (command)
P:	Execution by the program (statement)
Abbreviation:	Some statements allow the use of abbreviations. In this manual, the most simple form is shown. <Example> (Abbreviation ... P. #) This is an abbreviation for PRINT# , but the following forms can also be used: PR.#, PRI.#, and PRIN.#

CLOSE

M,P

FORMAT: CLOSE [#file number, #file number ...]

Abbreviation: CLOS.

See Also: OPEN

PURPOSE:

Closes a file.

REMARKS:

The **CLOSE** statement (command) closes a file having the specified file number. The file number must be specified as **#2** to **#7**. When no file number is specified, all the files are closed (serial I/O file **#1** is also closed). Then, the file number can be used in the same way as for the other files. All the files are closed in the following cases:

- When the **END**, **NEW**, or **RUN** command is executed.
- When the program (binary) has been saved to the disk (the **SAVE** command has been executed) or has been read (the **LOAD** or **MERGE** command has been executed).
- When the power has been turned off (auto power off).

EXAMPLE:

CLOSE #2, #5

Closes the file **#2** and **#5**.

DSKF

M,P

FORMAT: DSKF (1)

Abbreviation: DS.

See Also:

PURPOSE:

Returns (displays) the size of the free disk area.

REMARKS:

- The **DSKF** statement (command) returns the size of the free disk area in units of bytes.

(Note) Because the disk is used in units of 512 bytes, a 200-byte program occupies a 512-byte area of the disk.

EOF

M,P

FORMAT: EOF (file number)

Abbreviation: EO.

See Also:

PURPOSE:

Detects the end of a file.

REMARKS:

- The **EOF** statement (command) checks whether all the data of a file (having the specified file number) has been read. The file number must be any between #2 and #7.
- When all data of the file has been read, the **EOF** statement (command) returns 1 (true) as a function value. When not so, it returns 0 (false).
- When a file having the specified file number is not open, an error occurs.

EXAMPLE:

IF EOF (2) THEN CLOSE #2

If the EOF condition of file #2 is detected, file processing is terminated.

EXAMPLE:

10 OPEN "X:A" FOR OUTPUT AS #2

20 PRINT #2, 123, 456, 789

30 CLOSE

40 OPEN "X:A" FOR INPUT AS #2

50 INPUT #2, A, B

60 X = EOF (2) ← All data has not been read.

70 INPUT #2,C

80 Y = EOF (2) ← All data has been read.

90 CLOSE:END

Execution of this program results in X = 0 and Y = 1.

FILES

M

FORMAT: FILES ["X:[file name]"]

Abbreviation: FI.

See Also: LFILES

PURPOSE:

Displays the name and attribute of the specified file.

REMARKS:

- If a file name is specified, only that file is displayed. If no file name is specified, all disk files are displayed.
- The file name, extension, and attribute are displayed in that order. They are separated by spaces.
- Wild card characters (* and ?) can be used for file name specification. A question mark stands for any character and an asterisk for a number of characters. **A??Z** is functionally equivalent to **AAZZ**, **AXYZ**, **AtoZ**, and so forth.
- If the down arrow key () or key is pressed, the subsequent files are displayed. In contrast, if the up arrow key () is pressed, the preceding file is displayed.
- If the , , or key is pressed or the key is pressed when the last file name is displayed, the computer enters the normal input (key-in) wait status.

EXAMPLE:

FILES "X:A*"

This **FILES** command displays all the files whose name begins with alphabetic character A.

INPUT#

M,P

FORMAT: INPUT #file number, variable [,variable, ..., variable]

Abbreviation: I.#

See Also: OPEN and PRINT#

PURPOSE:

Assigns file data to the specified variable.

REMARKS:

- The **INPUT#** statement (command) is effective only for files specified as input files in the **OPEN** statement.
- The file number must be a number specified in the **OPEN** statement.
- The following can be specified for variables:
 - Fixed variable, simple variable (**A**, **X**, **B\$**, **CD**, **EF\$**, etc.)
 - Array element (**B(10)**, **C\$(5,5)**, etc.)
 - Entire array (**B(*)**, **C\$(*)**, etc.)
- When the number of file data is less than that of the specified variables, an error occurs.
- The data and variable types must be the same (for example, a numeric value must be assigned to a numeric variable).
- A comma (,), space (**&20**), or **CR (&OD) + LF (&OA)** code can be used as a delimiter when data is read into a numeric variable.
- Any spaces preceding the data are ignored.
- When data is read into a character variable, a comma (,) or **CR(&OD) + LF(&OA)** code can be used as a delimiter. In addition, any spaces preceding the data are ignored. When double quotation marks (") are included in that data, the subsequent character string is ignored. When the double quotation mark appears at the beginning, data is read up to the next double quotation mark. A comma in a character string enclosed by double quotation marks is not assumed to be a delimiter.

EXAMPLE:

```
10: INPUT A$
20: INPUT B$
30: OPEN "X:ABC.DAT" FOR
    OUTPUT AS #2
40: PRINT #2, A$; ", " ; B$
50: CLOSE
60: OPEN "X:ABC.DAT" FOR
    INPUT AS #3
70: INPUT #3, C$, D$
80: PRINT C$
90: PRINT D$
100: CLOSE : END
```

<Execution>

RUN

ABCD

AB"C,D"

ABCD

AB

INIT

M

FORMAT: INIT "X:"

Abbreviation: INI.

See Also:

PURPOSE:

Initializes a disk.

REMARKS:

- Special care should be taken in **INIT** command execution because it deletes the entire contents of a disk. Because both sides of the disk can be used, type **INIT "X:"** and press the **ENTER** key to initialize the second side, after turning the disk over.

(Notes) Before using a new disk, it must be formatted using the **INIT** command.

KILL

M

FORMAT: KILL "X:file name"

Abbreviation: K.

See Also:

PURPOSE:

Deletes a file.

REMARKS:

- The **KILL** command deletes the specified file.
- If the specified file does not exist or the specified file is not open, an error occurs.
- When the attribute of the specified file is **P**, an error occurs and no deletion takes place. Change the attribute with the **SET** command, then delete the file.
- An extension can not be omitted except when the extension consists of spaces only.

EXAMPLE:

KILL "X:PRO1"

This **KILL** command deletes a file whose name is **PRO1**.

(Note) No wild card can be used for file names.

LFILES

M

FORMAT: LFILES["X:[file name]"]

Abbreviation: LF.

See Also: FILES

PURPOSE:

Prints the name and attributes of the specified file.

REMARKS:

- If a file name is specified, only that file is printed. If no file name is specified, all disk files are printed.
- Wild cards can be used for file name specification.

LOAD

M

FORMAT: LOAD "X:file name"[, R]

Abbreviation: LOA.

See Also: SAVE and CHAIN

PURPOSE:

Loads a BASIC program.

REMARKS:

- The **LOAD** statement deletes the program being executed and reads a program from the disk.
- When the program size increases as a result of **LOAD** statement execution and the program becomes too large for the program area, all the variables (except the fixed variables) are cleared. Generally, the contents of variables are retained.
- When the program is a binary program (code), all the files are closed. When it is an ASCII file, no file is closed. See the explanation of the **CLOSE** statement (command).
- When the extension is **.BAS**, it may be omitted.
- When an error occurs during a read operation, a binary program is not loaded. When the program is an ASCII program, it is loaded up to the program line immediately before that in which an error is detected.
- When a non-protected binary program (a program not protected by a password) is loaded, if the computer itself has already been protected, the loaded program may also be protected. In this case, press the RESET switch to initialize the computer memory, then load the program. When the program to be loaded is an ASCII program, it is not protected.
- If **,R** is specified, the program is loaded and executed from the beginning (first line).

LOC

M,P

FORMAT: LOC file number

Abbreviation:

See Also:

PURPOSE:

Returns the current position (logical) of a file.

REMARKS:

- The **LOC** statement (command) returns the number of records read and written after a file having the specified file number has been opened. One record is 256 bytes long.
- When a file having the specified file number has not been opened, an error occurs.

LOF

M,P

FORMAT: LOF file number

Abbreviation:

See Also:

PURPOSE:

Returns the size of the specified file.

REMARKS:

- The **LOF** statement (command) returns the size of a file having the specified file number. The actual file size is displayed in units of bytes.
- When a file having the specified file number has not been opened, an error occurs.

(Note) Because the disk is used in units of 512 bytes, the total size of all disk files will not equal the size of the used disk area (number of bytes).

MERGE

FORMAT: MERGE "X:file name"

Abbreviation: MER.

See Also: LOAD and CHAIN

PURPOSE:

Loads a program from the disk without deleting the program(s) stored in computer memory.

REMARKS:

The **MERGE** command loads a program immediately after the program stored in computer memory. Namely, any number of different programs can be stored together in computer memory. When a binary program is loaded, all the files are closed.

NAME

FORMAT: NAME "X:old file name" AS "[X:] new file name"

Abbreviation: NA.

See Also:

PURPOSE:

Changes the registered file name.

REMARKS:

- The **NAME** command updates the registered file name.
- When a file having the old file name does not exist or a file having the new file name already exists, an error occurs.
- When the attribute of a file having the old file name is **P** (write inhibition), an error occurs.
- When either of the above files (files having the old and new file names) has been opened, an error occurs.
- An extension can not be omitted except when the extension consists only of spaces.

OPEN

M,P

FORMAT: OPEN "X:file name" FOR mode AS #file number

Abbreviation: OP.

See Also: CLOSE

PURPOSE:

Enables data I/O to the disk (opens the circuit).

REMARKS:

- The **OPEN** statement (command) assigns a file number to a file so that the data file can be read or written.
- The file number must be any number from **2** to **7**. Then, file I/O (**INPUT#**, **PRINT#**, etc.) takes place using the specified file number.
- The mode must be one of the following. It specifies a file I/O mode.
 - INPUT:** Reads the existing file.
 - OUTPUT:** Creates and writes the new file.
 - APPEND:** Adds the file immediately after the existing one.
- If the **OUTPUT** mode is specified for an existing file, the new file is created after old file deletion.
- When the **APPEND** or **INPUT** mode has been specified, if the specified file does not exist, an error occurs.
- When the file attribute is **P**, if the **APPEND** or **OUTPUT** mode is specified, an error occurs (see the explanation for the **SET** command).
- When an attempt is made to open an already open file using the file number, it causes an error.
- An extension can not be omitted except when the extension consists only of spaces.

(Note) If the **OPEN** command is executed carelessly without specifying **AS** and subsequent entries, an error may occur. If an error occurs, first read the explanation of the RESET switch, then reset the error.

EXAMPLE:

OPEN "X:PRO1" FOR OUTPUT AS #3

This **OPEN** command places the **PRO1** file in the write mode, then writes data to the disk via a file having file number 3.

PRINT#

M,P

FORMAT: PRINT #file number, { expression
character string }

[{ , } { expression
character string } { , } [{ expression
character string }]]

Abbreviation: P.#

See Also: OPEN and INPUT#

PURPOSE:

Writes the contents of the specified variable to the disk.

REMARKS:

- The **PRINT#** statement (command) is effective only for files for which **OUTPUT** or **APPEND** has been specified in the **OPEN** statement (command).
- The file number must be that specified in the **OPEN** statement (command).
- When an array variable (one or two dimensional) has been specified in the form of "array name (*)", the entire array is written to the disk. When the respective elements of the array are specified, they must be specified in the form of "**B(7)**", "**C\$(5,6)**", etc.
- If the entire array is specified, its elements are written in the order of **C\$(0,0)**, **C\$(0,1)**, **C\$(0,2)**, ... **C\$(1,0)**, ... **C\$(5,5)**.
- When a character or character variable other than the entire array is used, it must be connected by a comma (,) or semicolon (;) as shown in the following examples:
PRINT #2, "ABC"
PRINT #2, A\$
If **PRINT #2, "ABC", A\$** is executed, no data delimiter code is written and "ABC" and A\$ cannot be separated.
- The maximum number of files (including the program files) that can be written is 48 on one side of the disk.
- A numeric value is recorded in such a form that the sign (space when it is positive), numeric character string, and space appear in that order.

- The recording format is shown below.

- ① When a comma or semicolon does not follow the data, CR(&OD) and LF(&OA) are provided.

EXAMPLE:

PRINT #2, -1.2

-	1	.	2		CR	LF
---	---	---	---	--	----	----

PRINT #2, "ABC"

A	B	C	CR	LF
---	---	---	----	----

- ② When a comma follows the data, 20 bytes are occupied. A numeric value is right justified and a character string is left justified.

EXAMPLE:

PRINT #2, - 1.2,3

		~	-	1		2			3	.		CR	LF
← 20 bytes →													

PRINT #2, "ABC", "DEF"

A	B	C	~	D	E	F	CR	LF
← 20 bytes →								

When the character string exceeds 20 bytes, the excess part is written to the next 20-byte area. The absolute maximum size is 80 bytes.

- ③ When a semicolon follows the data, it is stored without spaces.

EXAMPLE:

PRINT #2, - 1.2;3

-	1	.	2		3	.		CR	LF
---	---	---	---	--	---	---	--	----	----

PRINT #2, "ABC";"DEF"

A	B	C	D	E	F	CR	LF
---	---	---	---	---	---	----	----

→ In this case, character strings "ABC" and "DEF" cannot be output separately.

SAVE

M,P

FORMAT: SAVE "X:file name"[, A]

Abbreviation: SA.

See Also: LOAD

PURPOSE:

Saves a BASIC program to the disk.

REMARKS:

- The **SAVE** statement (command) names a BASIC program in the computer's internal memory, then writes it to the disk.
- If **,A** is specified, the program is saved as an ASCII program. If it is omitted, the program is saved as a binary program after all the files are closed.
- If no extension is specified, **.BAS** is assumed. The extension can consist of up to three characters.
- If the existing file name is specified, the file is rewritten. In addition, if the attribute of the existing file is **P**, an error occurs.
- The maximum number of files (including the data files) is 48 for one side of the disk.
- When a program in the computer's internal memory has been password-protected, the **SAVE** statement (command) is ignored.

SET

M

FORMAT: SET "X:file name", attribute
The attribute must be **P** or a space.

Abbreviation: SE.

See Also:

PURPOSE:

Assigns or removes the file attribute(s).

REMARKS:

If **P** is specified for the attribute, the contents of the file cannot be inadvertently deleted or rewritten.

- Wild cards can be used for file name specification. But the extension cannot be omitted. For example, **.BAS** must be appended to the file name.
- To clear the attribute **P**, a space must be specified for the attribute. Then, the file can be read or written freely.
- If this command is executed for an open file, an error occurs.

SPECIFICATIONS

Model name:	CE-140F
Product name:	Pocket disk drive
Number of drives:	Single drive (single sided)/unit
Recording medium:	2.5-inch double-sided disk
Recording method:	GCR (4/5)
Number of tracks:	16 tracks/side (8 sectors/track, 512 bytes/sector)
Capacity:	64 K bytes (single side) 128K bytes (double sides) The user area size (at formatting) is 62464 Bytes (Single side).
Power source:	7.5V $\overline{\text{---}}$ (DC) Dry cell, size AA (or R6) \times 5 AC: AC adaptor (EA-160)
Power consumption:	2.5 W
Cell life:	Approx. 60 minutes for manganic cell SUM-3(C).R6P Approx. 200 minutes for alkaline cell AM-3.LR6 (These values are obtained when a 4K-byte program is written and read continuously at a temperature of 20°C.) The life of the dry cell may be shorter than the above values because of natural discharge. In addition, it may vary slightly depending on environment and use.
Temperature:	10°C to 35°C (environmental conditions for drive operation)
Humidity:	20% to 80% (without condensation)
Dimension:	118 (width) \times 145 (depth) \times 39 (height) mm
Weight:	Approx. 650 g (including cells)
Accessory:	Pocket disk (1), dry cell (5), operation manual (1)
Option:	CE-1650F (ten disks) EA-160 (adaptor)

(Note) A 2.5-inch (approx. 63.5 mm) disk indicates that the diameter of the disk is 2.5 inches.

EINLEITUNG

Wir danken Ihnen für den Kauf des SHARP Diskettenlaufwerks CE-140F. Um den sicheren und korrekten Betrieb des Gerätes zu gewährleisten, lesen Sie bitte diese Bedienungsanleitung sorgfältig durch und bewahren Sie sie immer in Nähe des Gerätes auf.

Anmerkung: Der Inhalt dieser Gebrauchsanleitung kann ohne Ankündigung geändert werden.

Bescheinigung des Herstellers/Importeurs

(nur für die Bundesrepublik Deutschland und West-Berlin anwendbar)

Hiermit wird bescheinigt, daß der/die/das
DISKETTENLAUFWERK Modell CE-140F
in Übereinstimmung mit den Bestimmungen der
Vfg. 1046/1984
funk-entstört ist.

Der Deutschen Bundespost wurde das Inverkehrbringen dieses Gerätes angezeigt und die Berechtigung zur Überprüfung der Serie auf Einhaltung der Bestimmungen eingeräumt.

SHARP ELECTRONICS (Europe) GmbH

INHALTS

	Seite
VORSICHT	41
MERKMALE DES DISKETTENLAUFWERKS	42
KOMPATIBLE TASCHENCOMPUTER	42
BEZEICHNUNG UND FUNKTIONEN	42
AUSWECHSELN DER BATTERIEN	44
ANSCHLUSS	45
STROMVERSORGUNG	45
GEBRAUCHSANLEITUNGEN	45
KONSTRUKTION UND HANDHABUNG DER DISKETTE	46
(1) Konstruktion der Diskette	46
(2) Schreibschutz	46
EINLEGEN/ENTFERNEN EINER DISKETTE	47
(1) Einlegen einer Diskette	47
(2) Entfernen einer Diskette	47
TECHNISCHE DATEN	48

VORSICHT

Dieses Gerät nicht in einem geschlossenen Auto oder an einem Ort mit direkter Sonnenstrahlung, hohen Temperaturen oder in der Nähe eines Heizkörpers aufbewahren. Sonst könnte es beschädigt werden.

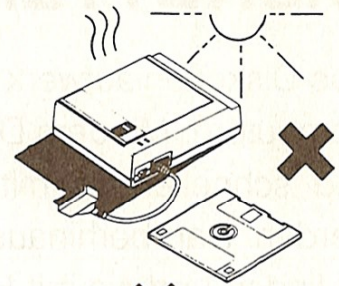

Stellen Sie das Gerät nicht in der Nähe von einem starken magnetischen Feld wie z.B. Fernsehapparat oder Magnet auf. Dadurch könnten Daten gelöscht oder andere Funktionsfehler verursacht werden.

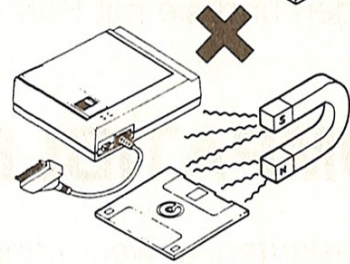

Das Gerät nicht an einem staubigen oder feuchten Ort lagern. Es könnte sonst eine Funktionsstörung verursacht werden.

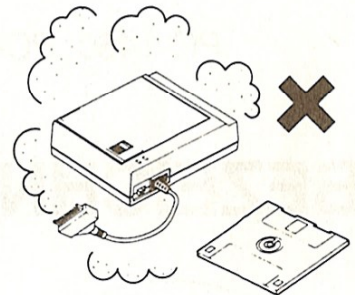

Berühren Sie nie die magnetische Oberfläche der Diskette, wenn der Verschluss geöffnet ist. Halten Sie die Diskette nicht an der Diskettennabe fest.

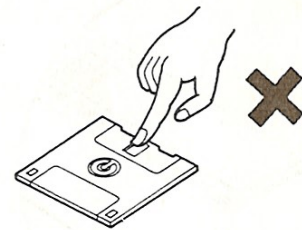

Um das Gerät zu reinigen, verwenden Sie ein weiches, trockenes Tuch, aber keine flüchtige Flüssigkeit wie z.B. ein Lösungsmittel oder Benzin.

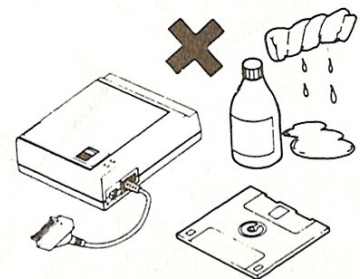

Nach ihrem Gebrauch die Diskette immer in der Plastik-hülle aufbewahren.



Die Diskette nicht in der Nähe von Nahrungsmitteln oder eines Aschenbechers aufbewahren.

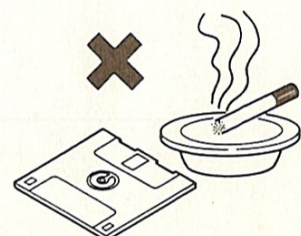

Die Diskette immer staubfrei halten. Eine verschmutzte Diskette könnte einen Funktionsfehler verursachen.

MERKMALE DES DISKETTENLAUFWERKS

Das Diskettenlaufwerk gleicht den üblichen Diskettenlaufwerken von Personal-Computern. Mit dem Diskettenlaufwerk können Programme oder Daten leichter und schneller als mit einem Kassettenrekorder geschrieben oder gelesen werden. Darüberhinaus ermöglicht es Ihnen, die gewünschten Daten schneller zu finden und sie mit Hilfe der Funktion **COPY** (Kopieren) zu sichern.

KOMPATIBLE TASCHENCOMPUTER

Das Diskettenlaufwerk kann an die folgenden Geräte angeschlossen werden:

PC-1460, PC-1425, PC-1403, PC-1360 (von Januar, 1987 an)

BEZEICHNUNG UND FUNKTIONEN

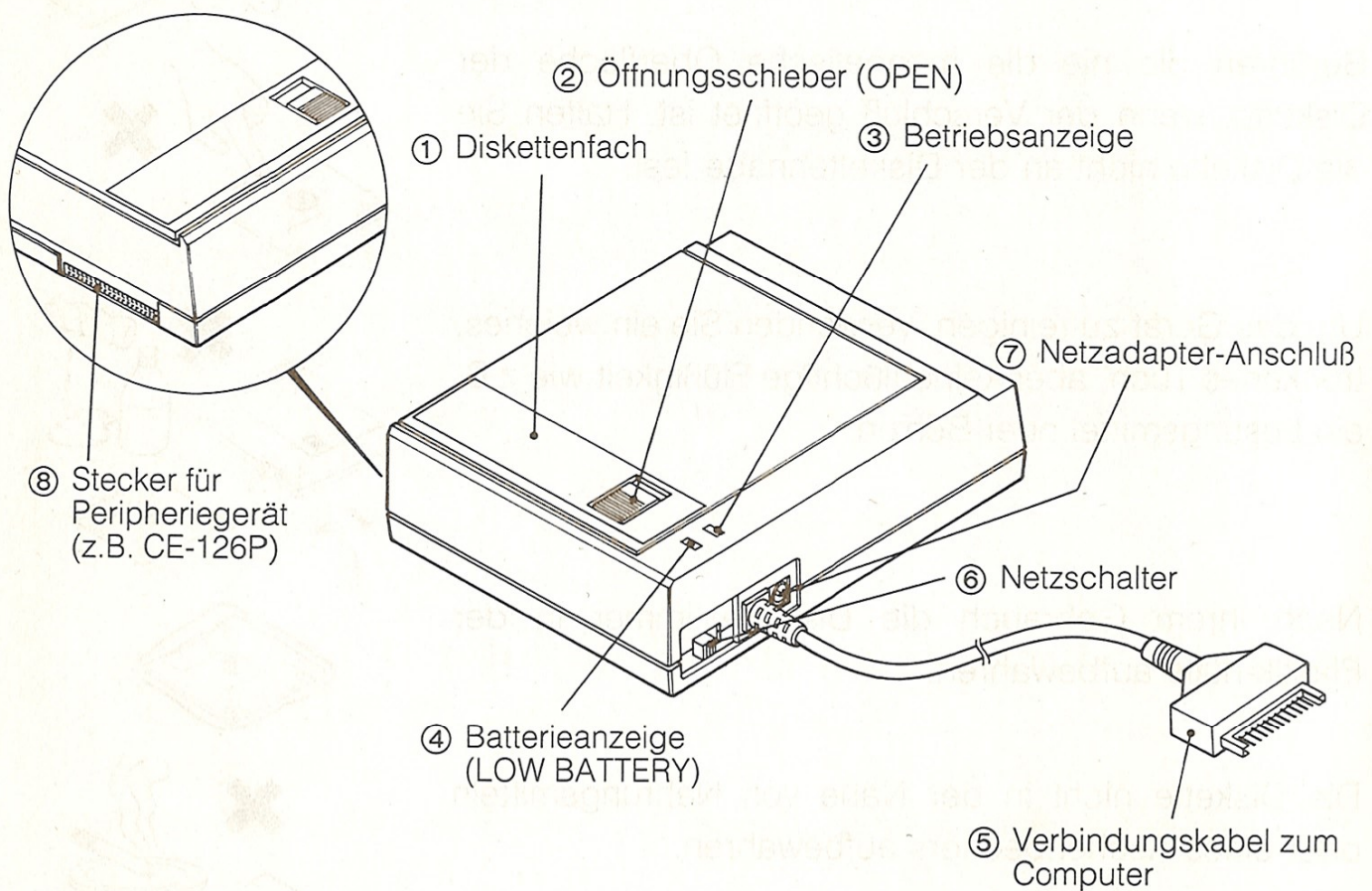

(1) Diskettenfach

Dieses Fach nimmt die Diskette auf. Schieben Sie den Öffnungsschieber in Pfeilrichtung (▲), um das Diskettenfach zu öffnen und legen Sie eine Diskette ein. (Siehe dazu Seite 47.)

(2) Öffnungsschieber (OPEN)

Bewegen Sie diesen Schieber in Pfeilrichtung (▲), um das Diskettenfach zu öffnen.

(3) Betriebsanzeige

Diese Lampe leuchtet auf, wenn das Gerät auf die Diskette oder den Computer Zugriff hat (d.h. während des Schreibens oder Lesens von Daten auf der Diskette oder der Datenübertragung zum oder vom Computer).

Anmerkung: Betätigen Sie nie den Öffnungsschieber, wenn diese Anzeige aufleuchtet.

Wird das Diskettenfach während des Diskettenzugriffs geöffnet, kann die Diskette beschädigt oder die Daten gelöscht werden. Diese Anzeige leuchtet auch auf, wenn ein Druckbefehl ausgeführt wird. Sie zeigt keinen Fehler an.

(4) Batterieanzeige (LOW BATTERY)

Diese Anzeige leuchtet auf, wenn die eingelegten Batterien fast verbraucht sind. In diesem Fall, schalten Sie den Netzschalter aus und wechseln die Batterien durch neue aus oder schließen einen Netzadapter (EA-160) an.

Achtung: Schalten Sie unbedingt den Netzschalter des Diskettenlaufwerks aus bevor Sie das Netzgerät anschließen, weil sonst die gespeicherten Daten gelöscht oder die Diskette zerstört werden könnte.

(5) Verbindungskabel zum Computer

Mit diesem Kabel wird das Gerät an den Computer angeschlossen. Für den Transport des Gerätes ist der Stecker mit der Schutzkappe zu versehen. Entfernen Sie die Kappe, bevor das Kabel angeschlossen wird.

(6) Netzschalter (POWER)

Stellen Sie diesen Schalter auf ON, um die Stromversorgung einzuschalten.

(7) Netzadapter-Anschluß

Über diese Buchse wird das Gerät mit dem Netzadapter verbunden.

(8) Stecker für Peripheriegerät

Über diesen Stecker wird das Gerät mit dem Drucker CE-126P verbunden.

AUSWECHSELN DER BATTERIEN

Diese Gerät wird über Batterien und/oder einen Netzadapter betrieben. Legen Sie die Batterien ein, bevor Sie versuchen das Taschen-Diskettenlaufwerk zu benutzen. Wenn die Batterieanzeige aufleuchtet, wechseln Sie die Batterien folgendermaßen aus:

- (1) Schalten Sie die Netzschalter des Computers, des Diskettenlaufwerks und anderer Peripheriegeräte aus.
- (2) Lösen Sie die Schrauben des Batteriefachdeckels und nehmen diesen ab.

Beim Auswechseln der Batterien darauf achten, daß alle verbrauchten Batterien gleichzeitig ausgewechselt werden.

- (3) Legen Sie die neuen Batterien ein. Versuchen Sie nicht alte und neue Batterien zusammen zu gebrauchen.
- (4) Führen Sie die Zungen des Batteriefachdeckels ein, setzen den Deckel ein und ziehen die Schrauben fest.

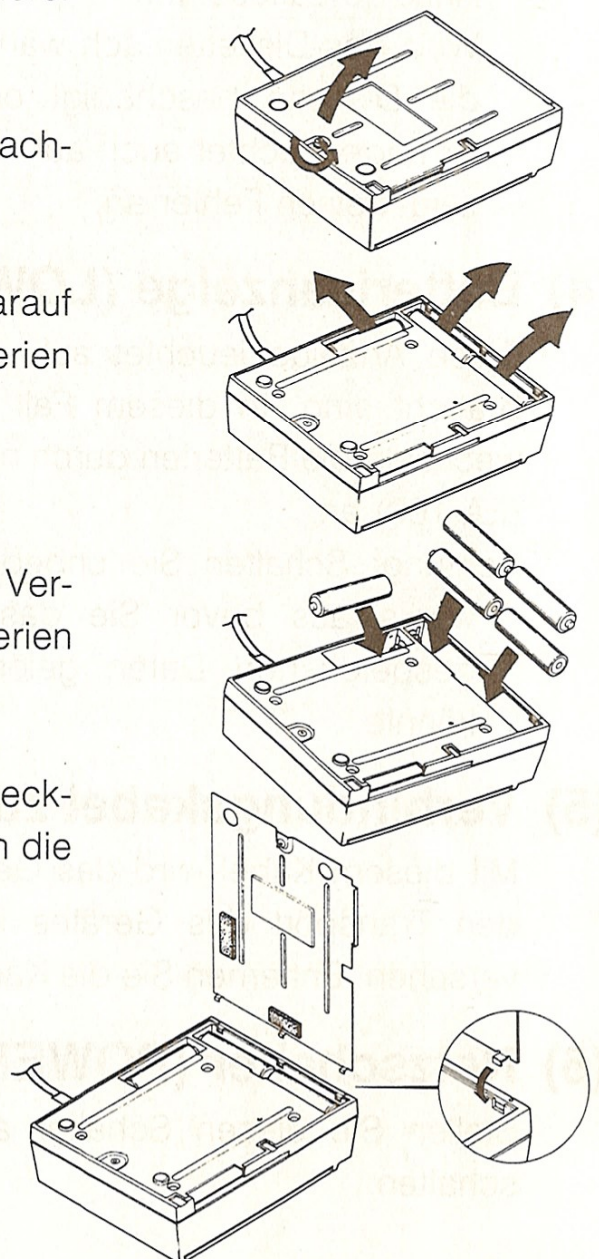

ANSCHLUSS

Schließen Sie das Diskettenlaufwerk über das Verbindungskabel an.

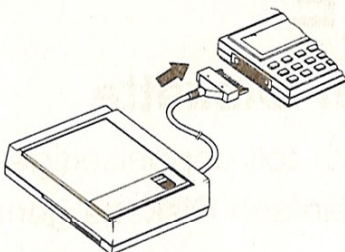

STROMVERSORGUNG

Um die Stromversorgung einzuschalten, gehen Sie folgendermaßen vor:

- ① Schalten Sie den Netzschalter des Computers ein.
- ② Schalten Sie den Netzschalter des Diskettenlaufwerks ein.

Legen Sie eine Diskette in das Diskettenfach ein, nachdem der Computer und das Diskettenlaufwerk eingeschaltet sind. Um den Computer und das Diskettenlaufwerk auszuschalten, führen Sie die oben beschriebenen Arbeitsgänge in der entgegengesetzten Reihenfolge aus. Nehmen Sie zuerst die Diskette aus dem Laufwerk und schalten dann die Netzschalter des Diskettenlaufwerks und des Computers aus. Warten Sie mindestens 5 Sekunden lang, bevor Sie den Computer und das Diskettenlaufwerk wieder einschalten.

GEBRAUCHSANLEITUNGEN

Da das Diskettenlaufwerk ein Präzisionsgerät ist, sollten bei seiner Benutzung und Lagerung die folgenden Punkte beachtet werden. Werden diese Vorsichtsmaßnahmen ignoriert, könnte das Diskettenlaufwerk beschädigt werden.

- ① Schalten Sie nie das Gerät mit eingelegter Diskette ein oder aus.
- ② Betätigen Sie nie den Öffnungsschieber während die Betriebsanzeige leuchtet. Sonst könnten die Daten gelöscht werden.
- ③ Falls die Batterieanzeige (rot) während des Betriebs des Laufwerks aufleuchtet, schalten Sie das Gerät nach dem Erlöschen der Betriebsanzeige aus und wechseln die Batterien aus oder schließen das Gerät an den Netzadapter an.
- ④ Schließen Sie das Diskettenlaufwerk richtig an und benutzen Sie es an einem sicheren, erschütterungsfreien Ort.
- ⑤ Die Netzschalter aller Systemkomponenten müssen vor dem Zusammenstecken ausgeschaltet werden.
- ⑥ Das Diskettenlaufwerk keinen starken Erschütterungen aussetzen. Stellen Sie keine schweren Gegenstände auf das Gerät.
- ⑦ Wenn das Diskettenlaufwerk für einen längeren Zeitraum nicht benutzt werden soll, entfernen Sie die Diskette und die Batterien aus dem Gerät.

KONSTRUKTION UND HANDHABUNG DER DISKETTE

(1) Konstruktion der Diskette

Dieses Gerät benutzt eine 2,5-Zoll doppelseitige Diskette mit doppelter Dichte (in dieser Betriebsanleitung einfach Diskette genannt).

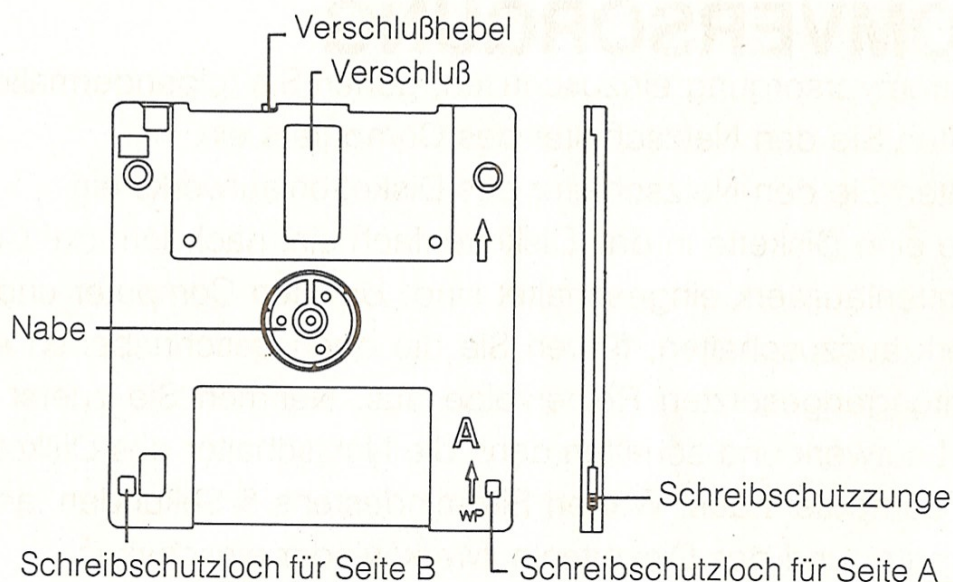

Verwenden Sie die mitgelieferte Diskette bzw. CE-1650F Disketten, die in Fachgeschäften erhältlich sind. Die Verwendung anderer Disketten könnte eine Funktionsstörung des Diskettenlaufwerks zur Folge haben.

- Disketten müssen vor ihrem Gebrauch im Diskettenlaufwerkwerk formatiert werden. Formatieren Sie immer eine neue Diskette bevor sie verwendet wird. Benutzen Sie dazu den Befehl **INIT**.

- ◆ Wenn Sie Disketten von einem Händler kaufen, der unsere Produkte führt, nennen Sie im einzelnen CE-1650F Disketten für das Gerät CE-140F.

(2) Schreibschutz

- Schieben Sie die Schreibschutzzunge in Pfeilrichtung (wie in Abb. 1 gezeigt), um zu verhindern, daß die Daten überschrieben oder gelöscht werden. Wenn Sie versuchen Daten auf einer schreibgeschützten Diskette (Schreibschutz) zu überschreiben oder zu löschen, wird ein Fehler angezeigt.

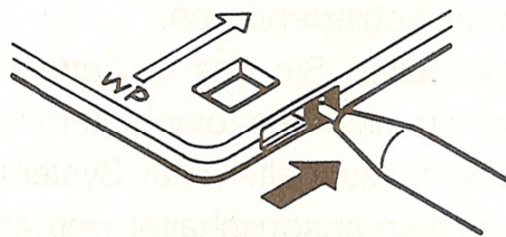

(Abb. 1)

- Um den Schreibschutz aufzuheben und damit das Überschreiben oder Löschen von Daten zu ermöglichen, schieben Sie die Schreibschutzzunge in die entgegengesetzte Richtung (wie in Abb. 2 gezeigt).

(Abb. 2)

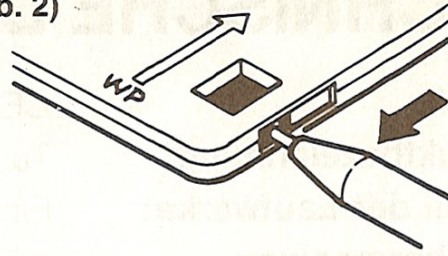

Ein Schreibschutz kann für beide Seiten (A und B) der Diskette angewendet werden.

EINLEGEN/ENTFERNEN EINER DISKETTE

- Um eine Diskette einzulegen oder zu entfernen, betätigen Sie den Öffnungsschieber, nachdem Sie sich vergewissert haben, daß die Betriebsanzeige nicht aufleuchtet.

(1) Einlegen einer Diskette

① Schieben Sie den Öffnungsschieber in Pfeilrichtung ①, um das Diskettenfach zu öffnen.

② Legen Sie die Diskette in die Diskettenfach mit der zu verwendenden Seite (A oder B) nach obenweisend ein. Drücken Sie die Diskette in Pfeilrichtung ②, bis sie eingerastet ist.

③ Drücken Sie das Diskettenfach in Pfeilrichtung ③, um es zu schließen. Wird die Diskette nicht richtig eingelegt, kann das Fach nicht geschlossen werden.

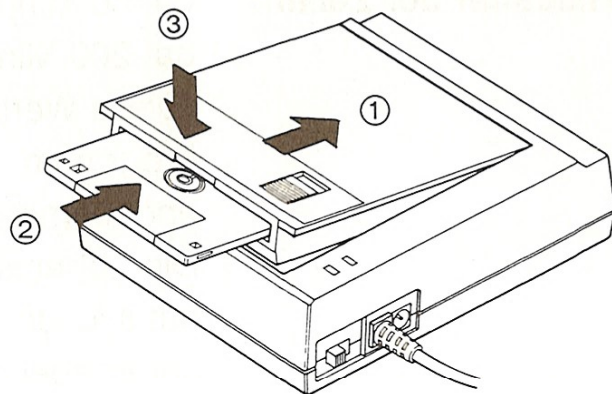

(2) Entfernen einer Diskette

Betätigen Sie den Öffnungsschieber in Pfeilrichtung ① in der Abbildung, um das Diskettenfach zu öffnen. Ziehen Sie die Diskette heraus und bewahren Sie sie in ihrer Plastikschrutzhülle auf.

TECHNISCHE DATEN

Modell:	CE-140F
Produktbezeichnung:	Taschendiskettenlaufwerk
Anzahl der Laufwerke:	Einzellaufwerk (einseitig)
Speichermedium:	2,5-Zoll doppelseitige Diskette
Aufzeichnungsmethode:	GCR (4/5)
Spurenzahl:	16 Spuren/Seite (8 Sektoren/Spur, 512 Bytes/Sektor)
Kapazität:	64K Bytes (einseitig) 128K Bytes (doppelseitig) Die Benutzerfläche (bei Formatierung) beträgt 62464 Bytes (einseitig)
Stromversorgung:	7,5V Gleichstrom (5 Trockenzellen) Wechselstrom: Netzadapter (EA-160)
Stromverbrauch:	2,5 W
Lebensdauer der Zellen:	ca. 60 Minuten für Manganzelle SUM-3(C).R6P ca. 200 Minuten für Alkalizelle AM-3.LR6 (Diese Werte werden erhalten, wenn ein 4K-Byte- Programm bei einer Temperatur von 20°C andauernd geschrieben und gelesen wird.) Die Lebensdauer der Zellen könnte wegen einer natürlichen Entladung kürzer sein als die angegebenen Werte. Sie könnte außerdem je nach den Umgebungsbedingungen und Geb- rauch etwas unterschiedlich sein.
Betriebstemperatur:	10°C bis 35°C (Umgebungsbedingungen für Laufwerkbetrieb)
Luftfeuchtigkeit:	20% bis 80% kondensationsfrei)
Abmessungen:	118 (Breits) × 145 (Tiefe) × 39 (Höhe) mm
Gewicht:	ca. 650 g (einschließlich der Zellen)
Zubehör:	Taschendiskette (1), Trockenzelle (5), Bedienungsanleitung (1)
Optionen:	CE-1650F (10 Disketten) EA-160 (Adapter)

(Anmerkung) Eine 2,5-Zoll-Diskette (ca. 63,5 mm) bedeutet, daß der Disketten-Durchmesser 2,5 Zoll beträgt.

INTRODUCTION

Merci d'avoir porté votre choix sur l'unité de micro-disque, SHARP CE-140F. Pour assurer un fonctionnement sûr et correct, veuillez lire attentivement ce manuel d'utilisation et le conserver toujours à proximité de l'appareil.

Remarque: Le contenu de ce manuel est sujet à des changements sans notice préalable.

TABLES DES MATIERES

	Page
ATTENTION	51
CARACTERISTIQUES DE L'UNITE DE MICRO-DISQUE	52
MATERIEL COMPATIBLE (ordinateurs de poche ou portatifs)	52
NOMENCLATURE ET FONCTION	52
REPLACEMENT DES PILES	54
CONNEXION	55
ALIMENTATION	55
PRECAUTIONS D'UTILISATION	55
CONSTRUCTION ET MANIPULATION DU MICRO-DISQUE	56
(1) Construction du micro-disque	56
(2) Interdiction d'écriture	56
CHARGEMENT ET DECHARGEMENT DU MICRO-DISQUE	57
(1) Chargement	57
(2) Déchargement	57
SPECIFICATIONS	58

ATTENTION

Evitez de placer l'appareil dans une voiture fermée ou un local sous ensoleillement direct, un endroit à haute température ou près d'un chauffage. Autrement, l'appareil pourrait être endommagé.

Evitez de rapprocher l'appareil d'un champ magnétique fort, tel qu'un téléviseur ou un aimant. Sinon, les données seront effacées ou détruites ou l'appareil risquerait de mal fonctionner.

Evitez d'utiliser ou de conserver l'appareil dans un endroit poussiéreux ou humide. Ceci pourrait constituer l'une des causes de panne.

Evitez de toucher le support magnétique du micro-disque, lorsque son volant est ouvert. Evitez également de tenir le micro-disque par son volant ou moyeu.

Pour le nettoyage de l'appareil, utilisez un chiffon mou sec, mais pas de liquide volatile, comme par exemple un diluant ou de la benzine.

Après son utilisation, conservez toujours le micro-disque dans une pochette en polyester.

Evitez de placer le micro-disque près de produits alimentaires ou d'un cendrier.

Maintenez le micro-disque toujours à l'abri de la poussière. Une impureté adhérent sur le micro-disque risquerait de provoquer une erreur de fonctionnement.

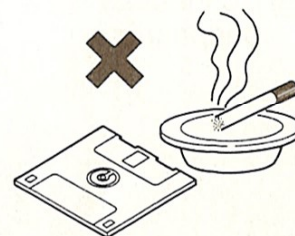
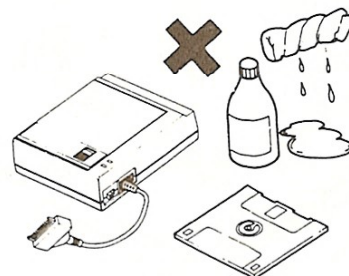
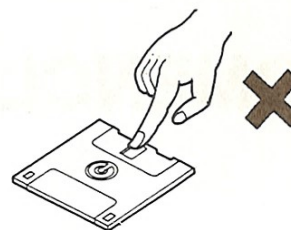
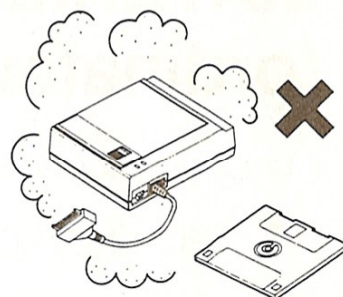
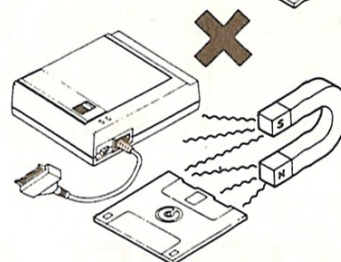
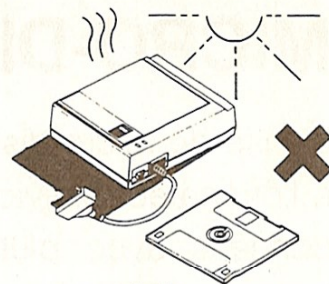

CARACTERISTIQUES DE L'UNITE DE MICRO-DISQUE

L'unité de micro-disque ressemble aux unités de disque habituelles intégrées à l'ordinateur individuel. L'unité de micro-disque permet d'écrire ou de lire les données avec plus de simplicité et de rapidité qu'avec l'enregistreur à cassette. Par ailleurs, elle permet de rechercher une donnée désirée avec beaucoup plus de facilité et de sauvegarder des données par la simple commande **COPY** (copiage).

MATERIEL COMPATIBLE (ordinateurs de poche ou portatifs)

L'unité de micro-disque peut être connectée avec le matériel suivant:

PC-1460, PC-1403, PC-1425, PC-1360 (à partir de Janvier 1987)

NOMENCLATURE ET FONCTION

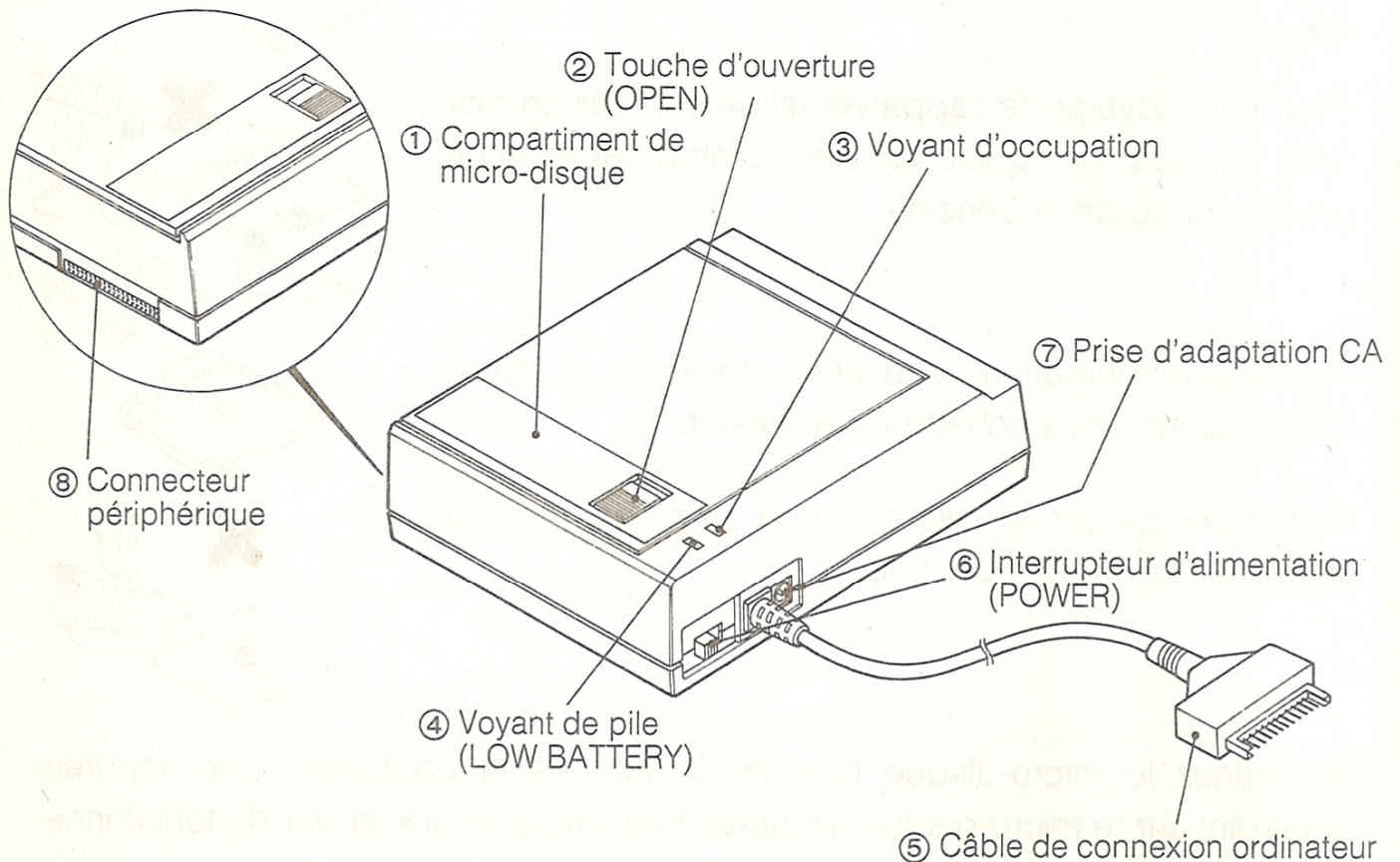

(1) Compartiment de micro-disque

Le compartiment de micro-disque reçoit le micro-disque. Pour le chargement d'un micro-disque, ouvrez le compartiment en poussant la touche d'ouverture dans le sens de la flèche (▲). (Voir la page 57.)

(2) Touche d'ouverture (OPEN)

Poussez cette touche dans le sens de la flèche (▲) pour ouvrir le compartiment de micro-disque.

(3) Voyant d'occupation

Ce voyant s'allume lorsque cet appareil est en accès au micro-disque ou à l'ordinateur (pendant l'écriture ou la lecture des données sur la disquette ou l'échange de données avec l'ordinateur).

Remarque: N'utilisez jamais la touche d'ouverture lorsque ce voyant est allumé.

L'ouverture du compartiment de micro-disque au cours de l'accès de l'appareil au micro-disque ou à l'ordinateur peut effacer des données ou constituer l'une des causes de pannes. A noter que ce voyant s'allume momentanément lors de l'exécution d'une commande associée à l'imprimante; ceci ne signifie pas la panne.

(4) Voyant de pile (LOW BATTERIE)

Ce voyant signale que la pile intégrée est presque épuisée. Lorsque ce voyant s'allume, mettez l'appareil hors tension à l'aide de l'interrupteur d'alimentation et remplacez la pile par une neuve ou branchez un adaptateur c.a. optionnel (EA-160). Si vous essayez de brancher un adaptateur c.a. avec l'interrupteur d'alimentation enclenché, les données stockées peuvent être effacées ou détruites et l'appareil risque de ne plus fonctionner.

(5) Câble de connexion ordinateur

Ce câble sert à relier l'appareil et l'ordinateur. Lors de l'expédition de cet appareil, sa borne correspondante est munie d'un chapeau de protection. Pour l'utilisation du câble de connexion, enlevez le chapeau.

(6) Interrupteur d'alimentation (POWER)

Sur la position ON, l'appareil est mis sous tension et sur, la position OFF, il est hors tension.

(7) Prise d'adaptation c.a.

Cette prise sert à relier l'appareil et l'adaptateur c.a. (EA-160) qui est en option.

(8) Connecteur périphérique

Ce connecteur sert à lier l'appareil et l'imprimante CE-126P.

REEMPLACEMENT DES PILES

Cet appareil fonctionne sur piles intégrées (ou courant de secteur par l'intermédiaire d'un adaptateur c.a.). Utilisez des piles R6.

Lorsque le voyant de pile s'allume, remplacez les piles en procédant comme suit:

- (1) Mettez tous les périphériques hors tension, y compris l'ordinateur et cet appareil.
- (2) Enlevez le couvercle du compartiment de piles.

Si les piles sont déjà en place, sortez-les.

- (3) Mettez en place cinq piles neuves. Veillez alors à ne pas confondre les piles neuves avec les anciennes.
- (4) Remettez le couvercle en place en engageant ses ergots sur les parties considérées du boîtier.

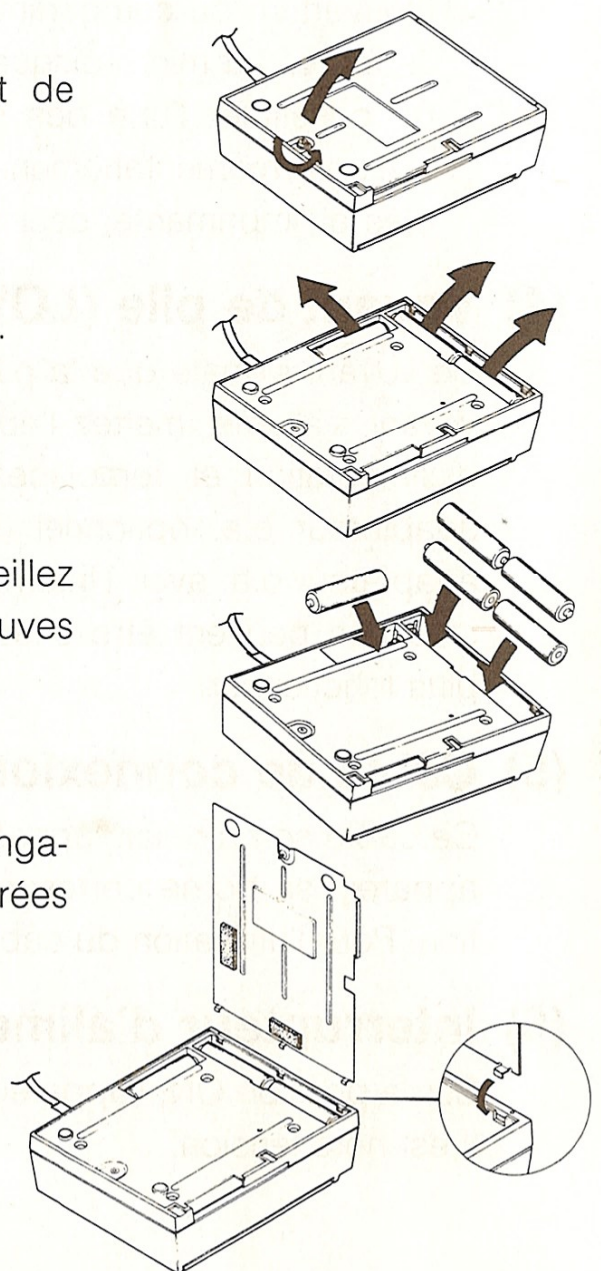

CONNEXION

Connectez l'appareil à l'ordinateur à l'aide du câble de liaison.

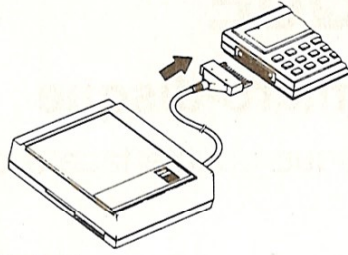

ALIMENTATION

Pour l'alimentation procédez comme suit:

- ① Enclenchez l'interrupteur d'alimentation de l'ordinateur.
- ② Enclenchez l'interrupteur d'alimentation de l'appareil.

Veillez à insérer un micro-disque dans le compartiment après avoir mis sous tension l'appareil et l'ordinateur.

Pour la mise hors tension, enlevez d'abord le micro-disque, puis coupez le courant de cet appareil et enfin coupez celui de l'ordinateur. Attendez au moins 5 secondes avant de procéder à la remise sous tension.

PRECAUTIONS D'UTILISATION

L'unité de micro-disque est un appareil de précision dont l'utilisation et la conservation nécessitent le respect des précautions suivantes pour éviter toute panne.

- ① Evitez de mettre l'appareil sous ou hors tension avec un micro-disque chargé dans son compartiment.
- ② Ne pas manipuler la touche d'ouverture, tant que le voyant d'occupation est allumé. Sinon, les données peuvent être effacées ou détruites.
- ③ Si le voyant de pile s'allume pendant l'écriture ou la lecture des données sur le micro-disque, mettez l'appareil hors tension après l'opération et remplacez les piles ou branchez l'appareil sur le courant de secteur avec un adaptateur c.a.
- ④ Utilisez cet appareil en le plaçant horizontalement. Evitez de le faire fonctionner dans un endroit où il y a des vibrations.
- ⑤ Pour le branchement ou débranchement de tous les appareils périphériques, y compris cet appareil, mettez-les hors tension.
- ⑥ Ne pas donner de choc fort à cet appareil. Evitez notamment de placer une lourde charge sur l'appareil.
- ⑦ Lorsque l'appareil n'est pas utilisé pendant une longue période, sortez le micro-disque et les piles de l'appareil.

CONSTRUCTION ET MANIPULATION DU MICRO-DISQUE

(1) Construction du micro-disque

Cet appareil utilise un micro-disque double face à densité double d'un format dit de "poche" de 2,5".

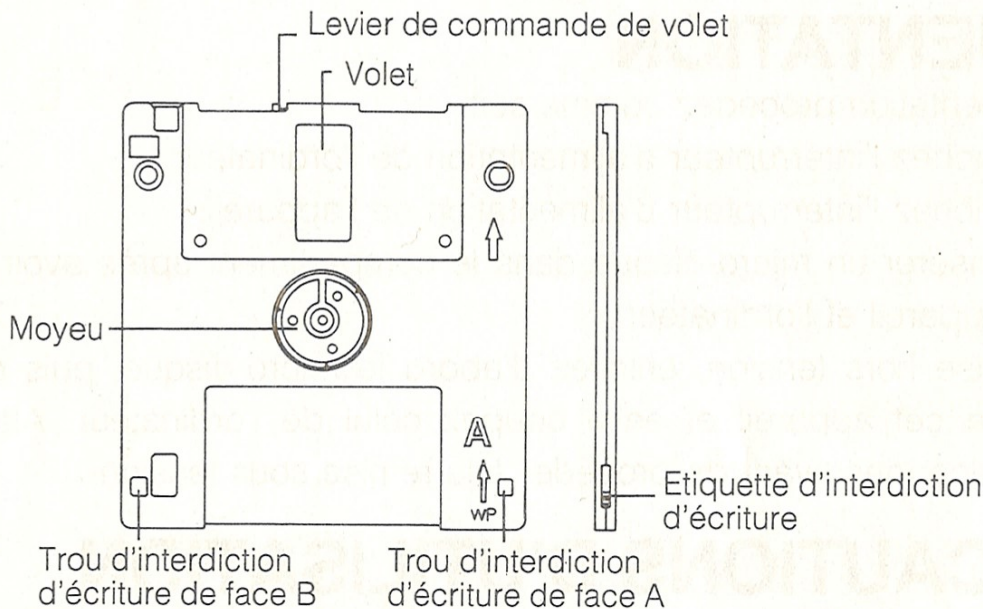

Utilisez le micro-disque prévu en accessoire ou une disquette CE-1650F optionnelle. L'utilisation d'un autre micro-disque peut constituer l'une des causes d'un mauvais fonctionnement ou de panne.

- Un micro-disque, s'il n'est pas formaté, ne peut pas être utilisé avec cet appareil. S'il s'agit d'un micro-disque vierge, assurez-vous de le formater pour cet appareil avant l'utilisation. (Pour le formatage, utilisez la commande **INIT.**)

- ◆ Pour l'achat d'un nouveau micro-disque, adressez-vous au magasin le plus proche en spécifiant "le micro-disque CE-1650F pour l'ordinateur CE-140F".

(2) Interdiction d'écriture

- Pour empêcher l'écriture ou l'effacement des données, déplacez l'étiquette d'interdiction d'écriture dans le sens de la flèche illustrée sur la figure 1. La tentative d'effacement ou d'écriture de données dans cette condition provoque une erreur.

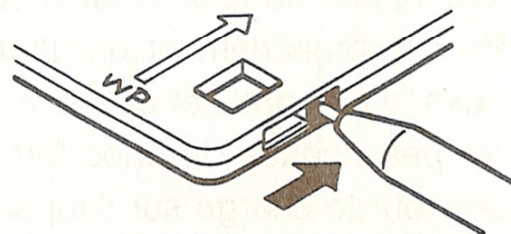

(Figure 1)

- Si vous déplacez l'étiquette dans le sens de la flèche de la figure 2, l'état d'interdiction d'écriture est supprimé en permettant l'écriture ou l'effacement de données.

(Figure 2)

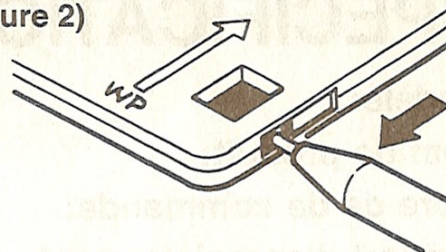

A noter que l'interdiction d'écriture est individuellement conditionnée pour les faces A et B. Veillez donc à ne pas les intervertir lors de cette opération.

CHARGEMENT ET DECHARGEMENT DU MICRO-DISQUE

- Pour le chargement ou le déchargement du micro-disque, manipulez la touche d'ouverture après avoir vérifié que le voyant d'occupation est éteint.

(1) Chargement

① Poussez la touche d'ouverture dans le sens de la flèche ① illustrée ci-contre. Le compartiment de micro-disque s'ouvre alors.

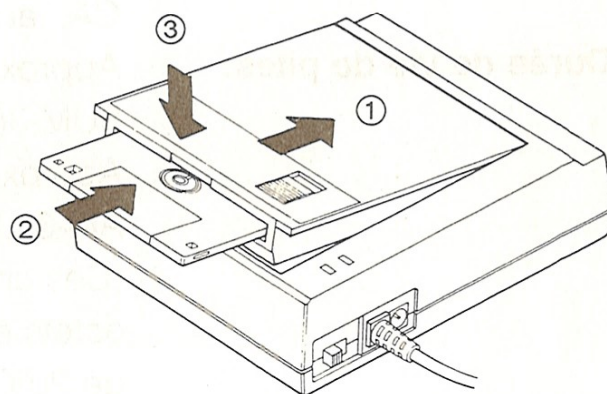

② Insérez à fond le micro-disque dans le compartiment, la face (A ou B) à utiliser orientée vers le haut (flèche ②).

③ Fermez le compartiment de micro-disque en l'abaissant légèrement (flèche ③).

Si le micro-disque n'est pas complètement chargé dans le compartiment, celui-ci ne peut pas être fermé. Dans ce cas, ne forcez pas, mais enfoncez le micro-disque à fond.

(2) Déchargement

Lorsque vous poussez la touche d'ouverture dans le sens de la flèche ① illustrée ci-dessus, le compartiment de micro-disque est ouvert; retirez alors le micro-disque.

- Conservez le micro-disque dans une pochette en polyester.

SPECIFICATIONS

Modèle:	CE-140F
Nom de produit:	Unité de micro-disque
N°bre de de commande:	Une (simple face)/unité
Support d'enregistrement:	Micro-disque à double face de 2,5 pouces
Mode d'enregistrement:	GCR (4/5)
N°bre de pistes:	16 pistes/face (8 secteurs/piste, 512 octets/secteur)
Capacité:	64 k octets (simple face) 128 k octets (double face) La zone destinée à l'utilisateur (au formatage) est de 62 464 octets (en double face).
Alimentation:	7,5V $\overline{\text{---}}$ (CC) avec 5 piles sèches du format AA (ou R6) CA: adaptateur CA (EA-160)
Durée de vie de piles:	Approx. 60 mn pour les piles au manganèse SUM-3(C).R6P Approx. 200 mn pour les piles alcalines AM-3.LR6 (Ces chiffres supposent qu'un programme de 4 k octets est écrit et lu en continu à une température de 20°C.) La durée de vie des piles sèches peut être réduite par suite d'une décharge spontanée. De plus, elle dépend légèrement de la condition ambiante d'utilisation.
Température:	10°C à 35°C (condition ambiante d'utilisation de l'unité)
Humidité:	20% à 80% (sans condensation)
Dimensions:	118 (largeur) × 145 (profondeur) × 39 (hauteur) mm
Poids:	Approx. 650 g (avec les piles intégrées)
Accessoires:	1 micro-disque, 5 piles sèches, 1 mode d'emploi
Options:	CE-1650F (dix disques) EA-160 (adaptateur)

(REMARQUE) Le disque de 2,5 pouces (approx. 63,5 mm) signifie que son diamètre est égal à 2,5 pouces.

SHARP CORPORATION

Osaka, Japan

PRINTED IN JAPAN/IMPRIME AU JAPON

7A 0.5-I(TINSL1114ECZZ)