

The LR1121 is an ultra-low power, long range LoRa® transceiver that provides support for terrestrial ISM band communications in the sub-GHz and global 2.4GHz spectrum, as well as S-Band support for satellite connectivity.

For all varieties of LPWAN use case, the LR1121 supports any combination of LoRa, (G)FSK, Long Range FHSS (LR-FHSS) modulations.

The LR1121 complies with the physical layer requirements of the LoRa Alliance® LoRaWAN® specification, while remaining configurable to meet different application requirements and proprietary protocols.

The transceiver is suitable for systems targeting compliance with radio standards including but not limited to ETSI EN 300 220, FCC CFR 47 Part 15, ARIB, and Chinese regulatory requirements.



## Disclaimer

Long Range-Frequency Hopping Spread Spectrum (LR-FHSS) is a high link-budget, high-performance technology combining the benefits of a modulation employing low energy per bit and advanced frequency hopping schemes to achieve improved coexistence, spectral efficiency and sensitivity. Semtech Corp. holds patents directed to aspects of the LR-FHSS technology.

Your use of LR-FHSS software made available by Semtech Corp. or its affiliates does not grant any rights to their patents for LR-FHSS technology. Rights under Semtech patents may be available via various mechanisms, including by purchasing Semtech SX1261, SX1262, SX1268, LR1110, LR1120, or LR1121 semiconductor devices, or their authorized counterparts from Semtech, or its affiliates, or their respective licensees.

## Ordering Information

Part Number	Delivery	Minimum Order Quantity
LR1121IMLTRT	Tape & Reel	3000 pieces

QFN32 Package, Pb-free, Halogen free, RoHS/WEEE compliant product.

## Revision History

Version	ECO	Date	Applicable to <sup>1</sup>	Changes
1.0	062817	Jul 2022	Use Case: 03 FW version: 01.00 or later	First Release
1.1	065940	Mar 2023	Use Case: 03 FW version: 01.00 or later	Include S-Band information Modified BRLORA RFIO_HF 2.4GHz typical value Section 1.2.4 rewritten Add reference to AN1200.74 in section 4.5 Modified section 1.2.1: air interface Modified Pinout pin 26 description Modified first 3 bullets of section 3.4 Added IDDTXHF3 & IDDTXHF4, & RXSLHF7 & RXSLHF10 parameters Modified section 4.1 Added section 5.6 Tape and Reel Information

1. Use Case and Version concepts are defined in the LR1121 User Manual, see the `GetVersion` command.

---

# Table of Contents

1. System Description .....	6
1.1 Simplified Block Diagram .....	6
1.2 Overview .....	7
1.2.1 Low-Power High-Sensitivity LoRa®/(G)FSK Half-Duplex RF Transceiver .....	7
1.2.2 Multi-Purpose Radio Front-End.....	7
1.2.3 Power Management.....	7
1.2.4 Clock Sources.....	7
1.2.5 Digital Subsystem .....	8
1.2.6 Cryptographic Engine.....	8
2. Pin Connection .....	9
3. Specifications .....	11
3.1 Absolute Maximum Ratings .....	11
3.2 Operating Range .....	11
3.3 ESD and Latch-up .....	12
3.4 Electrical Specifications .....	12
3.4.1 Power Consumption .....	12
3.4.2 General Specifications .....	15
3.4.3 Receiver .....	16
3.4.4 Transmitter .....	20
3.5 Reference Oscillator .....	21
3.6 Digital I/O, Flash Memory, & Interface Specifications .....	22
3.6.1 Digital I/O Specifications .....	22
3.6.2 Flash Memory Specifications.....	22
3.6.3 SPI Interface.....	22
4. Application Information.....	23
4.1 LR-FHSS Modulation .....	23
4.2 Exiting Sleep Mode .....	23
4.3 Digital Inputs/Outputs .....	24
4.3.1 DIO Configuration.....	24
4.3.2 RF Switch Control .....	24
4.3.3 Reset.....	24
4.3.4 Host Interrupts .....	25
4.4 Firmware Upgrade/ Update .....	25
4.5 Simplified Reference Schematic .....	26
4.6 Example Reference Layout .....	27
5. Package Information .....	28
5.1 Package Outline Drawing .....	28
5.2 Package Marking .....	29
5.3 Land Pattern .....	30
5.4 Reflow Profiles .....	30
5.5 Thermal Information .....	31
5.6 Tape & Reel Information .....	31

---

# List of Figures

Figure 1-1: LR1121 Simplified Block Diagram .....	6
Figure 2-1: LR1121 Pinout.....	10
Figure 4-1: Multi-band EU/US LoRaWAN Using Sub-GHz PAs .....	26
Figure 4-2: Reference Design Layout .....	27
Figure 5-1: Package Outline Drawing .....	28
Figure 5-2: Package Marking .....	29
Figure 5-3: Land Pattern .....	30
Figure 5-4: Tape & Reel Information.....	31

---

# List of Tables

Table 2-1: LR1121 Pinout.....	9
Table 3-1: Absolute Maximum Ratings.....	11
Table 3-2: Operating Range.....	11
Table 3-3: ESD and Latch-up .....	12
Table 3-4: Basic Modes Power Consumption.....	12
Table 3-5: Receive Mode Power Consumption, DC-DC mode used .....	13
Table 3-6: Transmit Mode Power Consumption .....	14
Table 3-7: General Specifications .....	15
Table 3-8: Receiver Specifications, Sub-GHz Bands .....	16
Table 3-9: Receiver Specifications, S-band and 2.4GHz ISM band.....	18
Table 3-10: Transmitter Specifications, sub-GHz Path.....	20
Table 3-11: Transmitter Specifications, S-band and 2.4GHz ISM band.....	20
Table 3-12: 32MHz Crystal Specifications.....	21
Table 3-13: 32MHz TCXO Regulator Specifications .....	21
Table 3-14: 32kHz Crystal Specifications .....	21
Table 3-15: Digital I/O and NRESET Specifications .....	22
Table 3-16: Flash Memory Specifications .....	22
Table 3-17: SPI Timing Requirements .....	22
Table 4-1: LR1121 DIO Mapping .....	24
Table 5-1: Package Thermal Information.....	31

# 1. System Description

## 1.1 Simplified Block Diagram

Figure 1-1: LR1121 Simplified Block Diagram

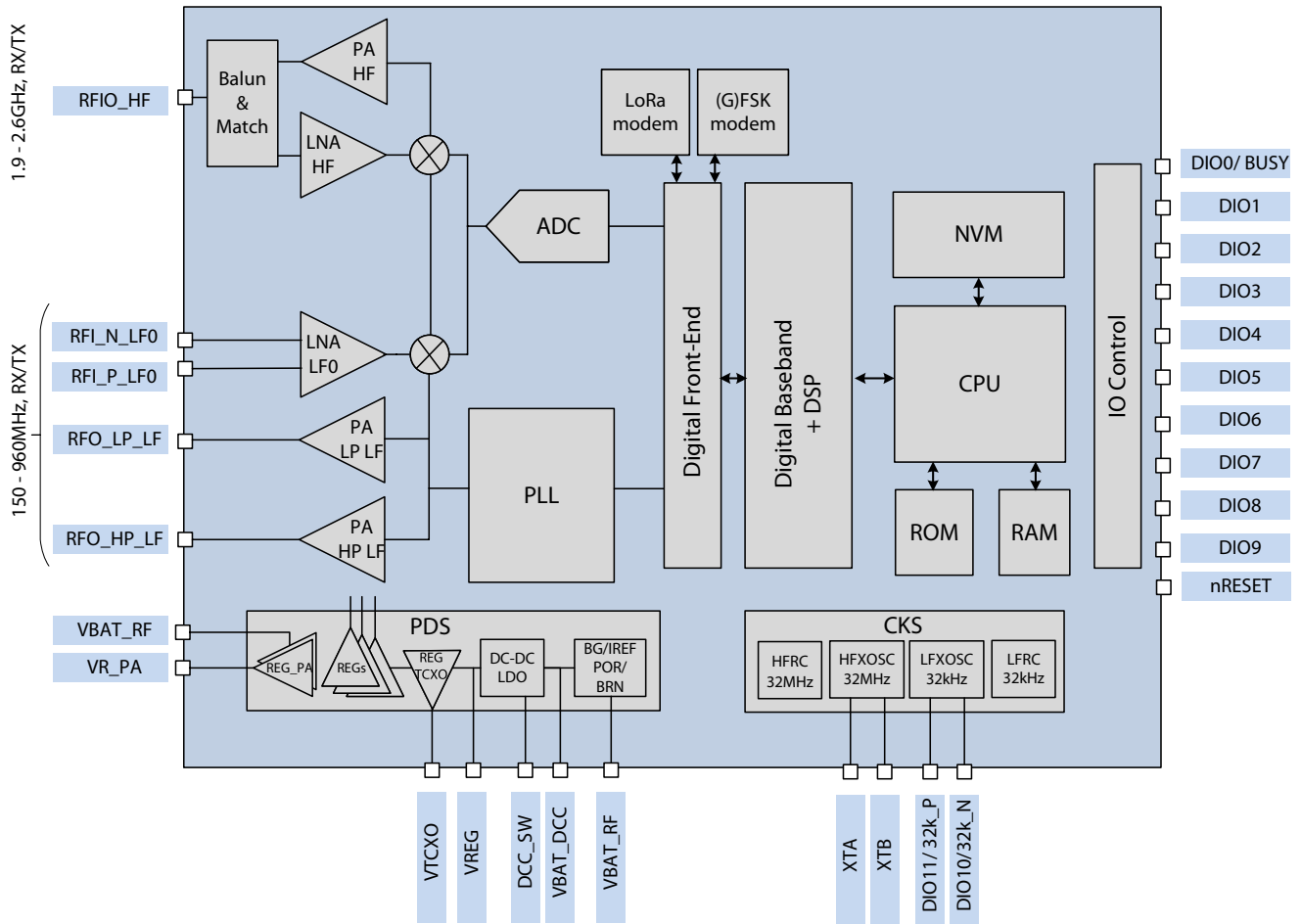

---

## 1.2 Overview

### 1.2.1 Low-Power High-Sensitivity LoRa<sup>®</sup>/(G)FSK Half-Duplex RF Transceiver

- Worldwide frequency bands support in the range 150 - 960MHz (sub-GHz), 1.9-2.1GHz S-band and 2.4GHz ISM band.
- Low Noise Figure modes for enhanced LoRa/ (G) FSK sensitivity (differential input pins RFI\_P/N\_LF0)
- High power PA path +22dBm (pin RFO\_HP\_LF) and High efficiency PA path +15dBm (pin RFO\_LP\_LF) for sub-GHz
- High frequency PA path +13dBm (pin RFIO\_HF) for 2.4GHz ISM band and S-band, matched to 50Ohm impedance, reducing the overall Bill Of Materials cost
- Integrated PA regulator supply selector to simplify dual power +15/+22dBm with a single board implementation
- Able to support world-wide multi-region BOM, the circuit adapts to satisfy regulatory limits
- Air interface fully compatible with the SX1261/2/8 family and the LoRaWAN standard, defined by the LoRa Alliance
- LR-FHSS Transmitter, with intra-packet hopping capability

### 1.2.2 Multi-Purpose Radio Front-End

- Continuous frequency synthesizer range from 150MHz - 2.5GHz
  - ◆ 1.9 to 2.5GHz handled by the RFIO\_HF RF port, already matched to 50 Ohms
  - ◆ All sub-GHz support handled by the other RF ports
- Digital baseband

### 1.2.3 Power Management

- Two forms of voltage regulation (DC-DC or linear regulator, LDO) are available depending upon the design priorities of the application. DC-DC usage is recommended for power efficient operation at the cost of an extra inductor.
- Power On Reset (POR), Brown-out detection and Low Battery indication are supported
- Battery voltage measurement

### 1.2.4 Clock Sources

- 32.768kHz Low Frequency (LF) internal RC oscillator, optionally used by the circuit Real Time Clock (RTC)
- 32.768kHz LF crystal oscillator (XOSC), used for the RTC. An external 32.768kHz reference from a host, applied to pin DIO11, is also possible.
- 32MHz HF RC (HFRC) oscillator allows configuration of the device without the need to start the main crystal oscillator
- 32MHz HF crystal oscillator (HFXOSC) for radio operations and to calibrate frequency error of internal RC oscillators
- 32MHz TCXO can be used to supply the main clock to the circuit, its power supply being integrated on-chip by REG\_TCXO, on pin VTCXO. The circuit is able to boot when a TCXO is connected instead of a 32MHz crystal, however all start-up (POR) calibrations are skipped. The host processor should program the TCXO configuration and re-launch the calibrations before further usage of the chip.
- For additional guidance on external clock sources (crystal and TCXO), refer to [Section 4.5](#).

---

## 1.2.5 Digital Subsystem

The circuit on-boards power-efficient functionalities, with sufficient hardware resources to implement a wide range of applications:

- Logic to control chip modes, radio front-end, power management and digital interfaces
- RAM partially retained during sleep mode
- Non-volatile memory (NVM)
- Slave serial peripheral interface (SPI)
- DIO0 used as "BUSY" indicator, indicating that the internal MCU cannot receive any commands from the host controller
- Hardware de-bounce and event detection (IOCD)
- Low-power real-time counter (RTC) and watch-dog timer (WDG)
- LoRa, (G)FSK, modems compatible with the SX126x and SX127x product families in sub-GHz bands
- LoRa, (G)FSK, modems compatible with the SX128x product families in the 2.4GHz ISM band
- Long Range FHSS in transmit mode, with intra-packet hopping capability

## 1.2.6 Cryptographic Engine

- Hardware support for AES-128 encryption/decryption based algorithms
- Handling device parameters such as DevEUI and JoinEUI, as defined by the LoRa Alliance
- Protects confidential information such as encryption keys against unauthorized access
- Stores NwkKey, AppKey, as defined in the LoRaWAN standard



## 2. Pin Connection

**Table 2-1: LR1121 Pinout**

Pin	Name	Type	Description
0	GND	-	Exposed Ground pad
1	VR_PA	O	Regulated power amplifier supply, for all power amplifiers
2	VBAT_RF	I	Battery supply
3	VTCXO	O	Internally generated supply for external TCXO frequency reference
4	XTA	-	32MHz crystal connection, or external TCXO frequency reference input
5	XTB	-	32MHz crystal connection, or NC in case of external TCXO usage
6	NRESET	I	Reset signal, active low
7	32k_P/ DIO11	I/O	32.768kHz crystal connection, or input for 32.768kHz reference clock/ Multi-purpose digital I/O
8	32k_N/ DIO10	I/O	32.768kHz crystal oscillator connection/ Multi-purpose digital I/O
9	DIO9	I/O	Multi-purpose digital I/O
10	DIO8	I/O	Multi-purpose digital I/O
11	DIO7	I/O	Multi-purpose digital I/O
12	VREG	O	Regulated output voltage from the internal regulator LDO/ DC-DC
13	GND	-	Ground
14	DCC_SW	-	DC-DC Switcher Output
15	VBAT	I	Battery supply
16	DNC	-	Do not connect
17	DNC	-	Do not connect
18	DNC	-	Do not connect
19	DIO6	I/O	Multi-purpose digital I/O
20	DIO5	I/O	Multi-purpose digital I/O
21	DIO4	I/O	Multi-purpose digital I/O
22	DIO3	I/O	Multi-purpose digital I/O
23	DIO2	I/O	Multi-purpose digital I/O
24	DIO1	I/O	Multi-purpose digital I/O
25	DIO0/BUSY	I/O	Multi-purpose digital I/O
26	RFIO_HF	I/O	RF input/output for any frequency over 1.9GHz
27	DNC	-	Do not connect
28	DNC	-	Do not connect
29	RFI_N_LF0	I	RF LF receiver input, sub-GHz operation
30	RFI_P_LF0	I	RF LF receiver input, sub-GHz operation
31	RFO_LP_LF	O	RF transmitter output for the low power PA, sub-GHz operation
32	RFO_HP_LF	O	RF transmitter output for the high power PA, sub-GHz operation

**Figure 2-1: LR1121 Pinout**

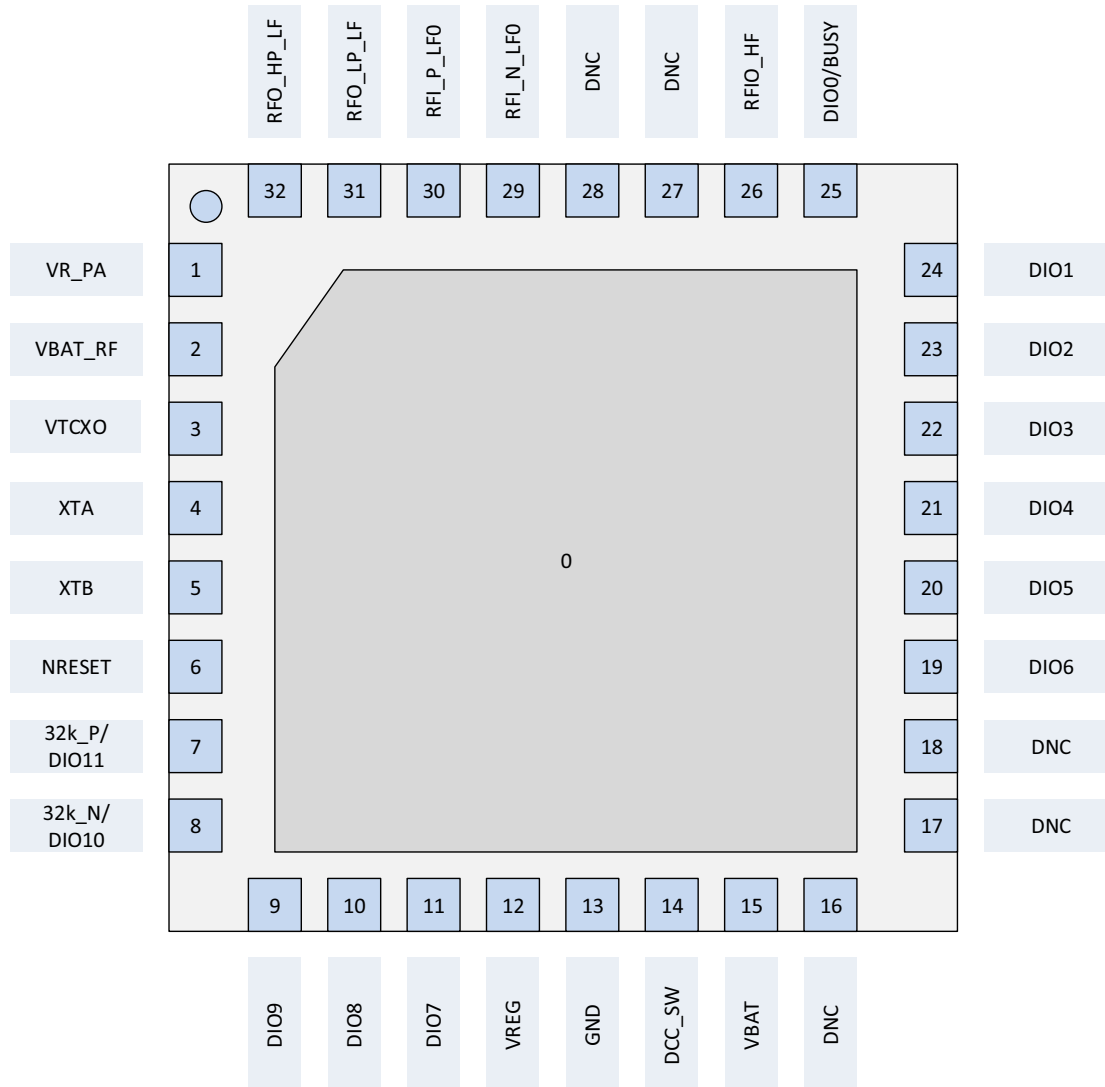

## 3. Specifications

### 3.1 Absolute Maximum Ratings

Stresses above the values listed below may cause permanent device failure. Exposure to absolute maximum ratings for extended periods may affect device reliability, reducing product life time.

**Table 3-1: Absolute Maximum Ratings**

Symbol	Description	Min	Typ	Max	Unit
VDDmr	Supply voltage	-0.5	-	3.9	V
Tmr	Temperature	-55	-	125	°C
Pmr	RF Input level	-	-	10	dBm

### 3.2 Operating Range

Operating ranges define the limits for functional operation and parametric characteristics of the device as described in this section. Functionality outside these limits is not guaranteed.

**Table 3-2: Operating Range**

Symbol	Description	Conditions	Min	Typ	Max	Unit
VDDop	Supply voltage		1.8	-	3.7	V
Top	Temperature under bias (ambient)		-40	-	85	°C
Clop	Load capacitance on digital ports		-	-	20	pF
ML	Maximum Input power	Sub-GHz path	-	-	0	dBm
VSWR	Voltage Standing Wave Ratio	Sub-GHz and RFIO_HF path	-	-	10:1	-

## 3.3 ESD and Latch-up

The LR1121 is a high performance radio frequency device presenting high ESD and latch-up robustness on all pins. The chip should be handled with all the necessary ESD precautions to avoid any permanent damage.

**Table 3-3: ESD and Latch-up**

Symbol	Description	Min	Typ	Max	Unit
ESD_HBM	Human Body Model, JEDEC standard JESD22-A114, class II	-	-	2.0	kV
ESD_CDM	ESD Charged Device Model, JEDEC standard JESD22-C101, class II	-	-	500	V
LU	Latch-up, JEDEC standard JESD78, class II level A	-	-	100	mA

## 3.4 Electrical Specifications

The tables below give the electrical specifications of the LR1121 transceiver under the following conditions, unless otherwise specified:

- VBAT\_RF = VBAT = 3.3V, Temperature = 25°C, FXOSC = 32MHz, crystal oscillator
- FRF = 915/869MHz on sub-GHz path RFI\_N/P\_LF0 and RFO\_HP/LP\_LF for FSK and LoRa
- Satellite band (S-band) in these tables describes specifications between 1.9 and 2.2GHz
- FRF = S-band and 2.45GHz for the RFIO\_HF path, same BOM used for all S-band and 2.45GHz specifications
- All RF impedances on the sub-GHz and RFIO\_HF path are matched using multi-band reference design, transmit mode output power defined in 50Ω load, RxBoosted = 1 for LoRa and FSK, differential use of the LNAs (receiver gain levels are referenced in the device's User Manual)
- FSK Bit Error Rate (BER) = 0.1%, 2-level FSK modulation without pre-filtering, BR = 4.8kb/s, FDA = 5kHz, BWF = 20kHz,
- LoRa Packet Error Rate (PER) = 1%, BWL= 125kHz, packet of 64 bytes, preamble of 8 symbols, error correction code CR=4/5, CRC on payload enabled, explicit header, sub-GHz frequency range
- Blocking Immunity, ACR, and co-channel rejection are given for a single tone interferer and referenced to sensitivity +3dB, blocking tests are performed with unmodulated interferer
- All power consumption numbers are given with XTAL mode used, the consumption of the TCXO has to be added
- All receiver bandwidths (BW) are expressed as **Double SideBand (DSB)** throughout this document

### 3.4.1 Power Consumption

The tables below give the total consumptions of all blocks in the specified modes of the circuit.

**Table 3-4: Basic Modes Power Consumption**

Symbol	Description	Conditions	Min	Typ	Max	Unit
IDDPDN	Supply current in power down mode		-	0.8	-	μA
IDDSL3	Supply current in SLEEP mode, no RTC	8kB RAM retained	-	1.6	-	μA
IDDSL1	Supply current in SLEEP mode	No RAM retained	-	1.6	-	μA
IDDSL3A	LFRC (32kHz) based RTC	8kB RAM retained	-	1.85	-	μA

**Table 3-4: Basic Modes Power Consumption**

Symbol	Description	Conditions	Min	Typ	Max	Unit
IDDSL2	Supply current in SLEEP mode	No RAM retained	-	1.5	-	μA
IDDSL4A	LFXOSC (32kHz) based RTC	8kB RAM retained	-	1.75	-	μA
IDDSBRLD	Supply current in STBY_RC	HFRG (32MHz) ON, LDO, System clock 16MHz	-	1.25	-	mA
IDDSBXLD	Supply current in STBY_XOSC	HFXOSC ON, LDO	-	1.3	-	mA
IDDSBXDC		HFXOSC ON, DC-DC	-	1.1	-	mA
IDDFSDC	Supply current in Synthesizer mode	DC-DC, system clock 32MHz	-	2.85	-	mA

**Table 3-5: Receive Mode Power Consumption, DC-DC mode used**

Symbol	Description	Conditions	Min	Typ	Max	Unit
IDDRXF1		FSK 4.8kb/s sub-GHz	-	5.4	-	mA
		with RxBoosted = 1	-	7.5	-	mA
IDDRXF2		FSK 4.8kb/s 2.4GHz/S-band	-	5.9	-	mA
		with RxBoosted = 1	-	6.6	-	mA
IDDRXL1	Supply current in Receive mode	LoRa® SF12 125kHz sub-GHz	-	5.7	-	mA
		with RxBoosted = 1	-	7.8	-	mA
IDDRXL2		LoRa® SF12 125kHz 2.4GHz/S-band	-	6	-	mA
		with RxBoosted = 1	-	6.7	-	mA
		LoRa® SF12 406kHz 2.4GHz/S-band	-	7.6	-	mA
		with RxBoosted = 1	-	8.3	-	mA
		LoRa® SF12 812kHz 2.4GHz/S-band	-	6.8	-	mA
		with RxBoosted = 1	-	7.5	-	mA

**Table 3-6: Transmit Mode Power Consumption<sup>1</sup>**

Symbol	Frequency Band	PA Match	Output Power	Min	Typ	Max	Unit
IDDTXLP1	868/915MHz	+14dBm, LP PA <sup>2</sup>	+15dBm	-	36	-	mA
IDDTXLP2			+14dBm	-	28	-	mA
IDDTXLP3			+10dBm	-	18.5	-	mA
IDDTXLP4	434/490MHz	+22dBm, HP PA <sup>3</sup>	+15dBm	-	35	-	mA
IDDTXLP5			+14dBm	-	28	-	mA
IDDTXLP6			+10dBm	-	19	-	mA
IDDTXHP1	868/915MHz	+22dBm, HP PA <sup>3</sup>	+22dBm	-	118	-	mA
IDDTXHP2			+20dBm	-	96	-	mA
IDDTXHP3			+17dBm	-	73	-	mA
IDDTXHP4			+14dBm	-	50	-	mA
IDDTXHP5	434/490MHz	+13dBm, HF PA	+22dBm	-	100	-	mA
IDDTXHP6			+20dBm	-	86	-	mA
IDDTXHP7			+17dBm	-	70	-	mA
IDDTXHP8			+14dBm	-	45	-	mA
IDDTXHF1	2.4GHz	+13dBm, HF PA	+13dBm	-	26	-	mA
IDDTXHF2			+10dBm	-	23	-	mA
IDDTXHF3	S-band	+13dBm, HF PA	+13dBm	-	28	-	mA
IDDTXHF4			+10dBm	-	24	-	mA

1. Using optimized settings described in the LR1121 User Manual

2. DC-DC mode of the LDO/DC-DC combo is used to supply the entire circuit

3. Battery used to supply the PA, and DC-DC used to supply the rest of the circuit

## 3.4.2 General Specifications

**Table 3-7: General Specifications**

Symbol	Description	Conditions	Min	Typ	Max	Unit
FRSYNTH	Synthesizer frequency range		150	-	2500	MHz
FSTEP	Synthesizer frequency step	$FXOSC / 2^{25}$	-	0.9536	-	Hz
HFOSCCP	32MHz Crystal oscillator supported off-chip capacitance	Single ended on XTA and XTB	0.2	1	3	pF
OSCTRM1	HF Crystal oscillator trimming step		-	1	-	ppm
LFCLKFR	Frequency of external LF clock applied on pin DIO11		-	32.768	-	kHz
LFCLKRF	Rise/fall time for external LF clock applied on pin DIO11		-	-	5	ns
BRFSK	Bit rate, FSK	Programmable, lowest setting	-	0.6	-	kb/s
	Minimum modulation index is 0.5	Programmable, highest setting	-	300 <sup>1</sup>	-	kb/s
FDAFSK	Frequency deviation, FSK	Programmable	-	0.6	-	kHz
		$FDA + BRF / 2 = < 250\text{kHz}$	-	200	-	kHz
BRLORA	Raw data rate, LoRa, sub-GHz	SF12, BWL = 62.5kHz, CR = 1/2	-	91	-	b/s
		SF5, BWL = 500kHz, CR = 4/5	-	62.5	-	kb/s
	Raw data rate, LoRa, RFIO_HF S-band	SF12, BWL=125kHz, CR=4/5	-	0.292	-	kb/s
		SF5, BWL=500kHz, CR=4/5	-	87.5	-	kb/s
Raw data rate, LoRa, RFIO_HF 2.4GHz	SF12, BWL=203kHz, CR=4/5	-	0.476	-	kb/s	
	SF5, BWL=812kHz, CR=4/5	-	101.5	-	kb/s	
BWL	Signal BW, LoRa	Programmable, lowest setting	-	62.5	-	kHz
		Programmable, highest setting	-	500 <sup>2</sup>	-	kHz
	Signal BW, LoRa, RFIO_HF S-band	Programmable, lowest setting	-	125	-	kHz
		Programmable, highest setting	-	500	-	kHz
	Signal BW, LoRa, RFIO_HF 2.4GHz	Programmable, lowest setting	-	203	-	kHz
		Programmable, highest setting	-	812	-	kHz
SF	Spreading factor coefficient, LoRa chips/symbol = $2^{\wedge}SF$	Programmable, lowest setting	-	5	-	-
		Programmable, highest setting	-	12	-	-
BWF	DSB channel filter BW, FSK, sub-GHz path	Programmable, lowest setting	-	4.8	-	kHz
		Programmable, highest setting	-	467	-	kHz

1. Maximum bit rate is assumed to scale with the RF frequency; example 300kb/s in the 869/915MHz frequency bands and only 50kb/s @150MHz

2. For RF frequencies below 300MHz, the LoRa signal BW is limited to maximum 250kHz, the data rate being reduced accordingly

### 3.4.3 Receiver

**Table 3-8: Receiver Specifications, Sub-GHz Bands**

Symbol	Description	Conditions	Min	Typ	Max	Unit
FRRXLF	RX input frequency	Sub-GHz frequency range, LoRa and FSK <sup>1</sup>	150	-	960	MHz
ZINRXLF	RX input impedance	Impedance across RFI_N_LF0 / RFI_P_LF0 <sup>2</sup> 433MHz 868MHz 920MHz	-	29 - j289 9.4 - j141 9.5 - j131	-	Ohm Ohm Ohm
PHNLF1	Synthesizer phase noise <sup>3,4</sup> sub-GHz band	100kHz offset	-	-102	-	dBc/Hz
PHNLF2		1MHz offset	-	-120	-	dBc/Hz
PHNLF3		10MHz offset	-	-129	-	dBc/Hz
RXS2F1	Sensitivity 2-FSK	BRF = 0.6kb/s, FDA = 0.8kHz, BWF = 4kHz	-	-123	-	dBm
RXS2F2		BRF = 1.2kb/s, FDA = 5kHz, BWF = 20kHz	-	-122	-	dBm
RXS2F3		BRF = 4.8kb/s, FDA = 5kHz, BWF = 20kHz	-	-117.5	-	dBm
RXS2F4		BRF = 38.4kb/s, FDA = 40kHz, BWF = 160kHz	-	-109	-	dBm
RXS2F5		BRF = 250kb/s, FDA = 125kHz, BWF = 500kHz	-	-103.5	-	dBm
RXS2F1HP3	Sensitivity 2-FSK, RxBoosted = 1	BRF = 0.6kb/s, FDA = 0.8kHz, BWF = 4kHz	-	-125	-	dBm
RXS2F2HP3		BRF = 1.2kb/s, FDA = 5kHz, BWF = 20kHz	-	-124	-	dBm
RXS2F3HP3		BRF = 4.8kb/s, FDA = 5kHz, BWF = 20kHz	-	-119	-	dBm
RXS2F4HP3		BRF = 38.4kb/s, FDA = 40kHz, BWF = 160kHz	-	-111	-	dBm
RXS2F5HP3		BRF = 250kb/s, FDA = 125kHz, BWF = 500kHz	-	-105	-	dBm
CCRFSK	Co-channel rejection, FSK		-	-8	-	dB
ACRFSK	Adjacent channel rejection, FSK	Offset = +/- 50kHz	-	47	-	dB
BIFSK1	Blocking immunity, FSK	BRF = 4.8 kb/s, FDA = 5kHz, BWF = 20kHz Offset = +/- 1MHz	-	67	-	dB
BIFSK2		Offset = +/- 2MHz	-	70	-	dB
BIFSK3		Offset = +/- 10MHz	-	80	-	dB
IIP3FSK	3rd order input intercept point, FSK	Unwanted tones @1MHz and 1.96MHz	-	-12	-	dBm
IMRFSK	Image attenuation, sub-GHz path	Without IQ calibration	-	40	-	dB
		With IQ calibration	-	50	-	dB
RXSL1	Sensitivity LoRa	BWL = 62.5kHz, SF = 7	-	-128	-	dBm
RXSL2		BWL = 62.5kHz, SF = 12	-	-142	-	dBm
RXSL3		BWL = 125kHz, SF = 7	-	-125	-	dBm
RXSL4		BWL = 125kHz, SF = 12	-	-139	-	dBm
RXSL5		BWL = 250kHz, SF = 7	-	-122	-	dBm
RXSL6		BWL = 250kHz, SF = 12	-	-136	-	dBm
RXSL7		BWL = 500kHz, SF = 7	-	-118	-	dBm
RXSL8		BWL = 500kHz, SF = 12	-	-132	-	dBm



**Table 3-8: Receiver Specifications, Sub-GHz Bands (Continued)**

Symbol	Description	Conditions	Min	Typ	Max	Unit
RXSL1HP7		BWL = 62.5kHz, SF = 7	-	-130	-	dBm
RXSL2HP7		BWL = 62.5kHz, SF = 12	-	-144	-	dBm
RXSL3HP7		BWL = 125kHz, SF = 7	-	-127	-	dBm
RXSL4HP7	Sensitivity LoRa,	BWL = 125kHz, SF = 12	-	-141	-	dBm
RXSL5HP7	RxBoosted = 1	BWL = 250kHz, SF = 7	-	-124	-	dBm
RXSL6HP7		BWL = 250kHz, SF = 12	-	-138	-	dBm
RXSL7HP7		BWL = 500kHz, SF = 7	-	-121	-	dBm
RXSL8HP7		BWL = 500kHz, SF = 12	-	-134	-	dBm
CCRLORA1	Co-channel rejection,	SF = 7	-	5	-	dB
CCRLORA2	LoRa	SF = 12	-	19	-	dB
ACRLORA1	Adjacent channel	Offset = +/- 1.5 x BW_L	-	60	-	dB
ACRLORA2	rejection, LoRa	BW_L = 125kHz, SF = 7	-	73	-	dB
BILORA1		SF = 12, offset = +/- 1MHz	-	88	-	dB
BILORA2		SF = 12, offset = +/- 2MHz	-	91	-	dB
BILORA3	Blocking immunity, LoRa,	SF = 12, offset = +/- 10MHz	-	103	-	dB
BILORA4	BW_L = 125kHz	SF = 7, offset = +/- 1MHz	-	74	-	dB
BILORA5		SF = 7, offset = +/- 2MHz	-	77	-	dB
BILORA6		SF = 7, offset = +/- 10MHz	-	90	-	dB
FERR	Max. tolerated frequency offset between Tx and Rx	SF5 to SF12 All bandwidths, ±25% of BW. The tighter limit applies (see below)	-	+/- 25%	-	BW_L
	Max. tolerated frequency offset between Tx and Rx	SF12	-50	-	50	ppm
		SF11	-100	-	100	ppm
		SF10	-200	-	200	ppm
FDRIFT	LoRa frequency drift tolerance	For sensitivity degradation below 3dB BW_L=125kHz, SF12, LowDataRateOptimize = 1	-	-	120	Hz/s

1. LoRa operation is on the 150 - 960MHz band
2. Single ended impedance
3. Phase Noise specifications are given for the recommended PLL bandwidth to be used for the specific modulation/ bit rate
4. Phase Noise is not constant over frequency, the topology of VCO + DIV used, for two frequencies close to each other, the phase noise could change significantly; the specification covers the worse value

**Table 3-9: Receiver Specifications, S-band and 2.4GHz ISM band**

Symbol	Description	Conditions	Min	Typ	Max	Unit
FRRXHF	RX input frequency	S-band, LoRa	1900	-	2200	MHz
		2.4GHz frequency range, LoRa and FSK	2400	-	2500	MHz
ZINRXHF	RX input impedance	Impedance across RFIO_HF, 2.4GHz	-	50 + j 0	-	Ohm
RXS2FHF2	Sensitivity 2-FSK	BRF = 1.2kb/s, FDA = 5kHz, BWF = 20kHz	-	-117	-	dBm
RXS2FHF3		BRF = 4.8kb/s, FDA = 5kHz, BWF = 20kHz	-	-112	-	dBm
RXS2FHF4		BRF = 38.4kb/s, FDA = 40kHz, BWF = 160kHz	-	-103	-	dBm
RXS2FHF5		BRF = 250kb/s, FDA = 125kHz, BWF = 500kHz	-	-97.5	-	dBm
CCRFSKHF	Co-channel rejection, FSK		-	-8	-	dB
ACRFSKHF1	Adjacent channel rejection, FSK	Offset = +/- 50kHz	-	33	-	dB
ACRFSKHF2		Offset = +/- 1MHz	-	58	-	dB
BIFSKHF1	Blocking Immunity, FSK	Offset = +/- 2MHz	-	63	-	dB
BIFSKHF2		Offset = +/- 10MHz	-	77	-	dB
IMRFSKHF	Image attenuation, FSK	Without IQ calibration	-	23	-	dB
RXSLHF1	Sensitivity LoRa Signal S-band	BWL = 125kHz, SF = 7	-	-118	-	dBm
RXSLHF2		BWL = 125kHz, SF = 12	-	-132.5	-	dBm
RXSLHF3		BWL = 250kHz, SF = 7	-	-116	-	dBm
RXSLHF4		BWL = 250kHz, SF = 12	-	-130	-	dBm
RXSLHF5		BWL = 500kHz, SF = 7	-	-112	-	dBm
RXSLHF6		BWL = 500kHz, SF = 12	-	-124.5	-	dBm
RXSLHF7	Sensitivity LoRa Signal 2.4GHz band RxBoosted = 1	BWL = 406kHz, SF = 5	-	-111	-	dBm
RXSLHF8		BWL = 406kHz, SF = 7	-	-129	-	dBm
RXSLHF10		BWL = 812kHz, SF = 5	-	-108	-	dBm
RXSLHF9		BWL = 812kHz, SF = 7	-	-112	-	dBm
CCRLORAHF1	Co-channel rejection, LoRa	BWL = 406kHz, SF = 7	-	5	-	dB
CCRLORAHF2		BWL = 406kHz, SF = 12	-	19	-	dB
CCRLORAHF3		BWL = 812kHz, SF = 7	-	5	-	dB
CCRLORAHF4		BWL = 812kHz, SF = 12	-	19	-	dB

**Table 3-9: Receiver Specifications, S-band and 2.4GHz ISM band (Continued)**

Symbol	Description	Conditions	Min	Typ	Max	Unit	
ACRLORAHF1		BWL = 406kHz, SF=7, Offset = +1.5 x BW_L	-	53	-	dB	
ACRLORAHF2		BWL = 406kHz, SF=7, Offset = -1.5 x BW_L	-	34	-	dB	
ACRLORAHF3		BWL = 406kHz, SF=12, Offset = +1.5 x BW_L	-	68	-	dB	
ACRLORAHF4	Adjacent channel rejection, LoRa	BWL = 406kHz, SF=12, Offset = -1.5 x BW_L	-	49	-	dB	
ACRLORAHF5		BWL = 812kHz, SF=7, Offset = +1.5 x BW_L	-	59	-	dB	
ACRLORAHF6		BWL = 812kHz, SF=7, Offset = -1.5 x BW_L	-	59	-	dB	
ACRLORAHF7		BWL = 812kHz, SF=12, Offset = +1.5 x BW_L	-	72	-	dB	
ACRLORAHF8		BWL = 812kHz, SF=12, Offset = -1.5 x BW_L	-	72	-	dB	
BILORAHF1			BWL = 406kHz, SF=7, Offset= +/- 1MHz	-	59	-	dB
BILORAHF2			BWL = 406kHz, SF=7, Offset= +/- 2MHz	-	64	-	dB
BILORAHF3			BWL = 406kHz, SF=7, Offset= +/- 10MHz	-	80	-	dB
BILORAHF4		BWL = 406kHz, SF=12, Offset= +/- 1MHz	-	73	-	dB	
BILORAHF5		BWL = 406kHz, SF=12, Offset= +/- 2MHz	-	79	-	dB	
BILORAHF6	Blocking Immunity, LoRa	BWL = 406kHz, SF=12 Offset= +/- 10MHz	-	94	-	dB	
BILORAHF7		BWL = 812kHz, SF=7, Offset= +/- 1MHz	-	57	-	dB	
BILORAHF8		BWL = 812kHz, SF=7, Offset= +/- 2MHz	-	61	-	dB	
BILORAHF9		BWL = 812kHz, SF=7, Offset= +/- 10MHz	-	78	-	dB	
BILORAHF10		BWL = 812kHz, SF=12, Offset= +/- 1MHz	-	70	-	dB	
BILORAHF11		BWL = 812kHz, SF=12, Offset= +/- 2MHz	-	76	-	dB	
BILORAHF12		BWL = 812kHz, SF=12 Offset= +/- 10MHz	-	91	-	dB	

### 3.4.4 Transmitter

**Table 3-10: Transmitter Specifications, sub-GHz Path**

Symbol	Description	Conditions	Min	Typ	Max	Unit
TXOPLP TXOPHP	Maximum TX power	LP PA	+12	+15	-	dBm
		HP PA	+19	+22	-	dBm
TXDRPLF1 TXDRPLF2	Drop in maximum TX power vs. VDD (1.8 to 3.7V)	LP PA operating under DC-DC or LDO	-	0.5	-	dB
		HP PA, operating under battery	-	6	-	dB
TXPRNGLF	TX power range	Programmable in steps of -1dB from maximum TX power	-	31	-	steps
TXACCLF	TX output power step accuracy		-	+/- 2	-	dB
TXRMPLF	Power amplifier ramping time	Programmable, lowest step	-	16	-	μs
		Programmable, highest step	-	304	-	μs
TXEVM	EVM for LR-FHSS	GMSK 488b/s	-	-	-20	dB

**Table 3-11: Transmitter Specifications, S-band and 2.4GHz ISM band**

Symbol	Description	Conditions	Min	Typ	Max	Unit
TXOPHF	Maximum TX power	HF PA	9	+11.5	-	dBm
TXDRPHF	Drop in maximum TX power vs. VDD (1.8 to 3.7V)	LP PA operating under DC-DC or LDO	-	0.5	-	dB
TXPRNGHF	TX power range	Programmable in steps of -1dB from maximum TX power	-	31	-	steps
TXACCHF	TX output power step accuracy		-	+/- 2	-	dB
TXRMPHF	Power amplifier ramping time	Programmable, lowest step	-	16	-	μs
		Programmable, highest step	-	304	-	μs
TXEVMHF	EVM for LR-FHSS	GMSK 488b/s	-	-	-20	dB

## 3.5 Reference Oscillator

**Table 3-12: 32MHz Crystal Specifications**

Symbol	Description	Conditions	Min	Typ	Max	Unit
FXOSCHF	Crystal oscillator frequency		-	32	-	MHz
CLOADHF	Crystal loading capacitance	Differential	9.5	10	10.5	pF
COXTALHF	Crystal shunt capacitance		0.3	0.6	2	pF
RSXTALHF	Crystal series resistance		-	30	60	$\Omega$
CMXTALHF	Crystal motional capacitance		1.3	1.89	2.5	fF
DRIVEHF	Drive level		-	-	100	$\mu$ W
FRTOLHF	Crystal frequency accuracy	Initial	-	-	+/- 10	ppm
		Over temperature (-20 to 70°C)	-	-	+/- 10	ppm
		Aging over 10 years	-	-	+/- 10	ppm

**Table 3-13: 32MHz TCXO Regulator Specifications**

Symbol	Description	Conditions	Min	Typ	Max	Unit
CVTCXO	External decoupling capacitor for REG_TCXO	X5R type recommended	70	100	130	nF
RVTCXO	Equivalent series resistance for CVTCXO		0.1	-	1	Ohm
VTCXO	Regulated voltage range for TCXO voltage supply, VDDop > VTCXO + 200mV	RegTcxoTune = 000	-	1.6	-	V
		RegTcxoTune = 001	-	1.7	-	V
		RegTcxoTune = 111	-	3.3	-	V
ILTCXO	Load current for TCXO regulator		-	1.5	4	mA
ATCXO	Amplitude voltage for external TCXO applied to XTA pin	AC coupled through 10pF DC-cut series with 220Ohm	0.4	0.6	1.2	Vpk-pk

**Table 3-14: 32kHz Crystal Specifications**

Symbol	Description	Conditions	Min	Typ	Max	Unit
FXOSCLF	Crystal oscillator frequency		32400	32768	33100	Hz
CLOADLF	Crystal loading capacitance	Differential	-	9.0	-	pF
COXTALLF	Crystal shunt capacitance		0.7	1.1	2	pF
RSXTALLF	Crystal series resistance		25	45	100	k $\Omega$
CMXTALLF	Crystal motional capacitance		1.5	4.7	8	fF
DRIVELF	Drive level		0.5			$\mu$ W
FRTOLLF	Crystal frequency accuracy	Initial	-	-	+/-20	ppm
		Over temperature (-20 to 70°C)	-	-	+/-180	ppm
		Aging over 10 years	-	-	+/-3	ppm

## 3.6 Digital I/O, Flash Memory, & Interface Specifications

### 3.6.1 Digital I/O Specifications

**Table 3-15: Digital I/O and NRESET Specifications**

Symbol	Description	Conditions	Min	Typ	Max	Unit
VIH	Input High Voltage		0.7*VBAT	-	VBAT+0.3	V
VIL	Input Low Voltage		-0.3		0.3*VBAT	V
VOH	Output High Voltage	$I_{max} = 2.5mA$	0.9*VBAT		VBAT	V
VOL	Output Low Voltage	$I_{max} = -2.5mA$	0		0.1*VBAT	V

### 3.6.2 Flash Memory Specifications

The LR1121 embeds a Flash memory for storing the internal firmware, application configuration data, and security keys.

**Table 3-16: Flash Memory Specifications**

Symbol	Description	Conditions	Min	Typ	Max	Unit
FEND	Flash Memory Endurance	$T_{op} = -40$ to $85^{\circ}C$	10,000	-	-	Cycles
FRET	Flash Memory Data Retention	$T_{op} = 85^{\circ}C$	10	-	-	Years

### 3.6.3 SPI Interface

The SPI interface gives access to the configuration register via a synchronous full-duplex protocol corresponding to CPOL = 0 and CPHA = 0 (clock polarity and phase in Motorola/NXP® Freescale™ nomenclature). Only the slave side is implemented. A transfer is always started by a falling edge of NSS. MISO is high impedance when NSS is high. The SPI runs on the external SCK signal to allow high speed operation up to 16MHz.

All timings in the following table are given for a maximum load capacitance of 10pF.

**Table 3-17: SPI Timing Requirements**

Symbol	Description	Min.	Typ.	Max.	
t1	NSS falling edge to SCK setup time	31.25	-	-	ns
t2	SCK period	61.5	-	-	ns
t3	SCK high time	31.25	-	-	ns
t4	MOSI to SCK hold time	5	-	-	ns
t5	MOSI to SCK setup time	15	-	-	ns
t6	NSS falling to MISO delay	0	-	15	ns
t7	SCK falling to MISO delay	0	-	15	ns

---

## 4. Application Information

### 4.1 LR-FHSS Modulation

The LR1121 supports LR-FHSS modulation (compliant with the LoRaWAN specification released by the LoRa Alliance), which modulates the packet content across several pseudo-random frequencies, providing the following benefits:

- In FCC regions, the LR-FHSS can eliminate the dwell-time limitation by intra-packet hopping. It thus allows to use slower data rates, which increases the communication range, and to carry a longer payload.
- In ETSI regions, the LR-FHSS can provide improved capacity and an even longer range than LoRa for lower data rate devices where the spectrum is limited such as Europe or India.
- The LR-FHSS modulation provides even better robustness in the presence of interferences than LoRa.

The LR1121 is able to generate LR-FHSS modulated packets on all sub-GHz, S-band and 2.4GHz ISM bands.

LR-FHSS implementation in the LR1121 is transmit only.

### 4.2 Exiting Sleep Mode

The LR1121 exits the lowest-power Sleep mode with:

- A falling edge on the NSS signal
- A RTC Timeout configured in the `SetSleep()` command, as an option

Implementation options are detailed in the User Manual, and both can be combined.

## 4.3 Digital Inputs/Outputs

The LR1121 features 12 digital input/output (DIO) pins, dedicated to host or sensors/peripherals communication, interruption handling and external RF switches or LNA control.

### 4.3.1 DIO Configuration

The LR1121 features a DIO switch matrix (SWM), allowing a reconfiguration of the DIOs depending on the application requirements. For a transceiver use case, the LR1121 is controlled by a host MCU, hence the DIOs are dedicated to host communication. In order to reduce the constraints on the MCU pin count, five DIOs can be used to control external RF switches or LNAs.

**Table 4-1: LR1121 DIO Mapping**

Pin	I/O Name	Function
6	NRESET	NRESET
7	32k_P/ DIO11	32k_P/ NC
8	32k_N/ DIO10	32k_N/ RFSW4
9	DIO9	IRQ
10	DIO8	RFSW3
11	DIO7	RFSW2
19	DIO6	RFSW1
20	DIO5	RFSW0
21	DIO4	SPI MISO
22	DIO3	SPI MOSI
23	DIO2	SPI SCK
24	DIO1	SPI NSS
25	DIO0/ BUSY	BUSY

### 4.3.2 RF Switch Control

The LR1121 can control up to 5 external RF switches or LNAs on the RFIO\_HF and Sub-GHz RF paths, reducing the number of host controller IOs required for the application. This allows you to select application MCUs with a reduced pin count or a smaller footprint and therefore design highly integrated solutions. The polarity of the RF switch control signals can be set in each radio mode. By default no DIO is used as RF switch control line, all RF switch outputs are kept in High-Z state.

### 4.3.3 Reset

A complete restart of the LR1121 internal firmware can be issued on request by toggling the NRESET pin. It will be automatically followed by the standard calibration procedure and any previous context will be lost. The pin should be held low for more than 100 $\mu$ s for the reset to occur.



---

### 4.3.4 Host Interrupts

The LR1121 offers 24 interrupt sources, allowing the host to react to special events in the LR1121 system without the need to poll registers, in order to design power optimized applications.

Interrupts to the host are signalled through one (or more) IRQ lines configured on the DIOs, and can be masked or cleared using dedicated commands.

The interrupt status can be read by the host through the 32-bit interrupt status register. They can be cleared by writing a 1 to the respective bit.

## 4.4 Firmware Upgrade/ Update

During the manufacturing process, the LR1121 will be provisioned and contain the embedded firmware image.

During the product assembly process, the customer will be able to upgrade the full embedded firmware image running on the LR1121 via the SPI interface. The bootloader of the LR1121 will authenticate the firmware and will allow further execution. Only firmware images provided by Semtech can run on the LR1121.

The LR1121 can also support patch updates, typically for maintenance in the field.

# 4.5 Simplified Reference Schematic

Figure 4-1: Multi-band EU/US LoRaWAN Using Sub-GHz PAs

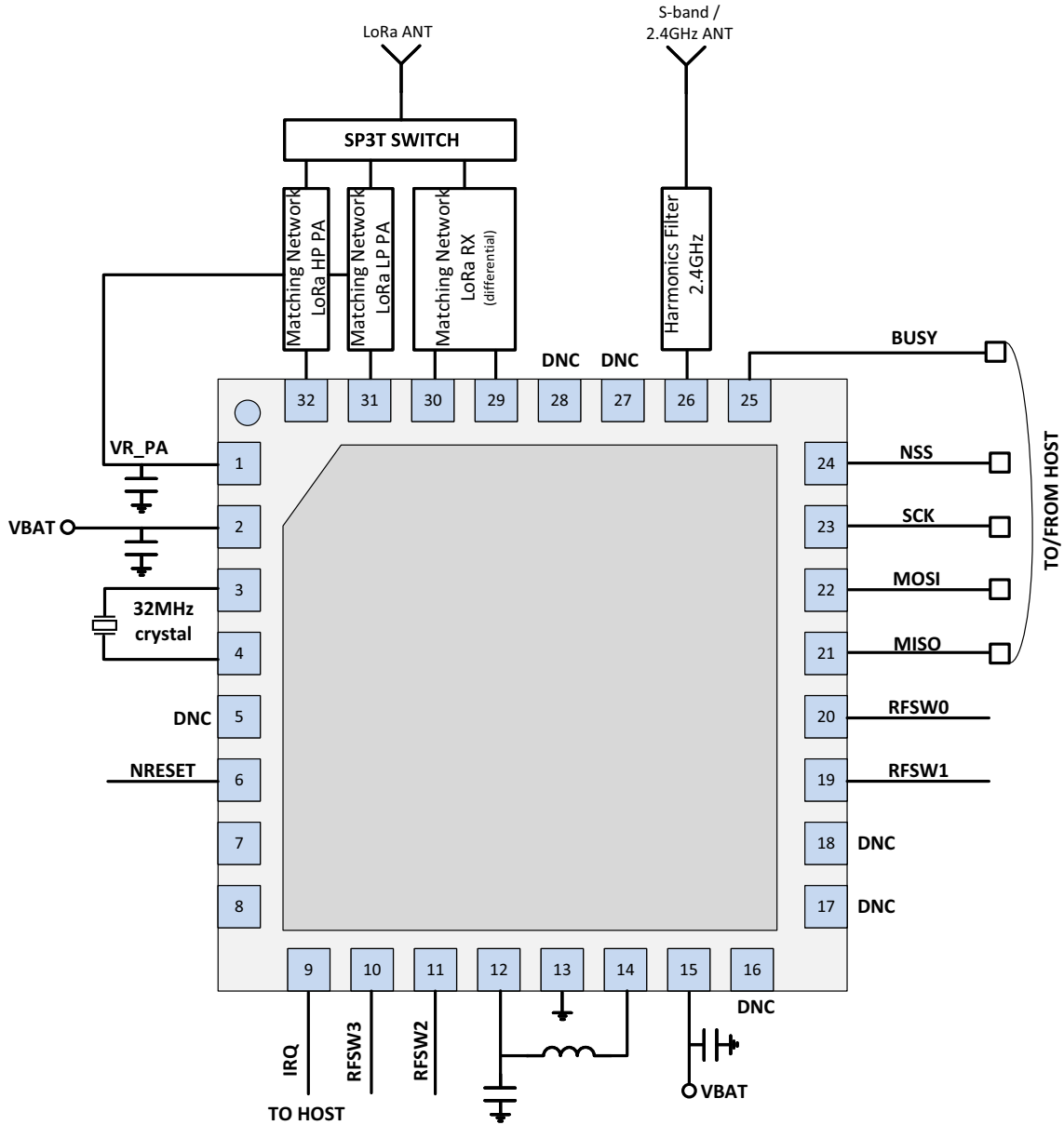

This section provides a reference schematic example using the LR1121.

- For additional guidance about 32M and 32k clock sources, refer to AN1200.74 LoRa Edge™ Clock Requirements.

---

## 4.6 Example Reference Layout

Figure 4-2: Reference Design Layout

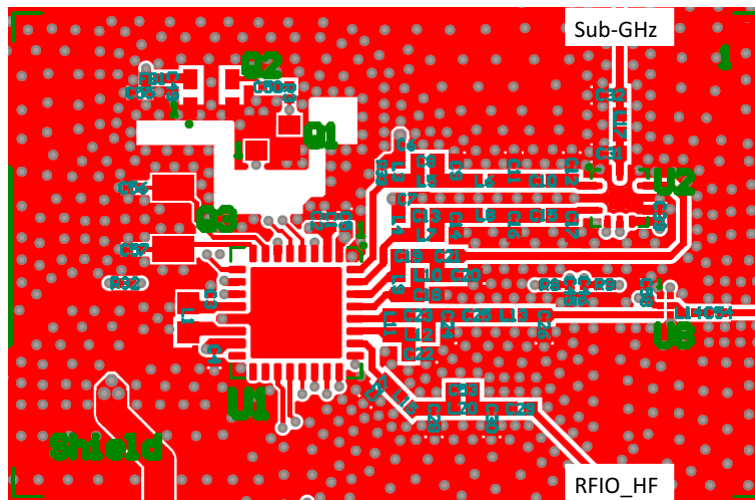

# 5. Package Information

## 5.1 Package Outline Drawing

Figure 5-1: Package Outline Drawing

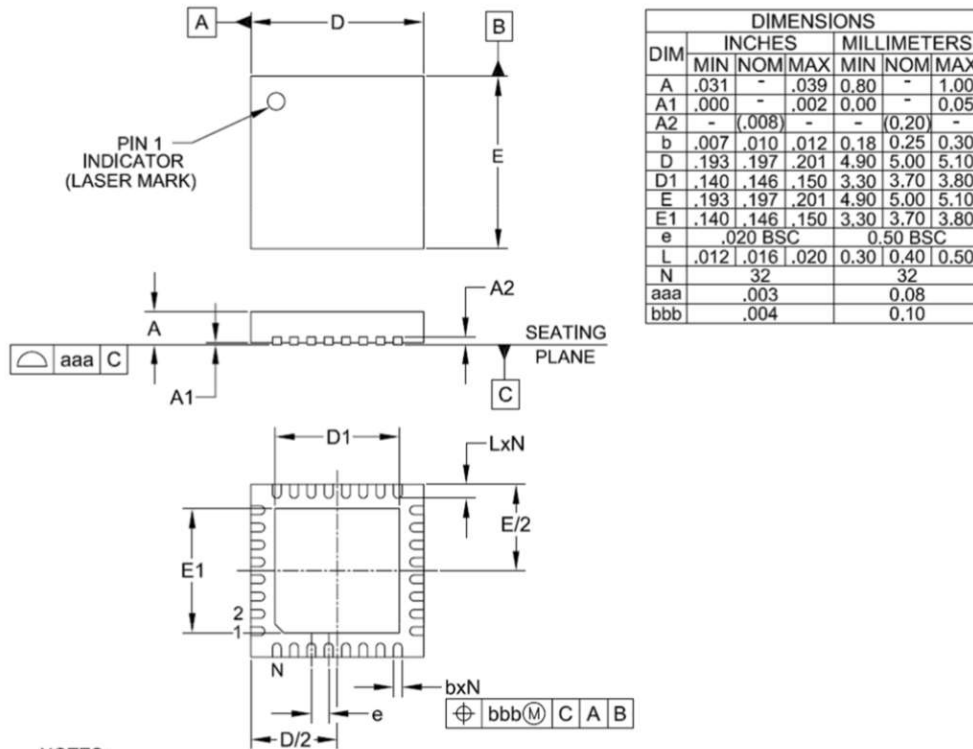

NOTES:

1. CONTROLLING DIMENSIONS ARE IN MILLIMETERS (ANGLES IN DEGREES).
2. COPLANARITY APPLIES TO THE EXPOSED PAD AS WELL AS THE TERMINALS.

## 5.2 Package Marking

Figure 5-2: Package Marking

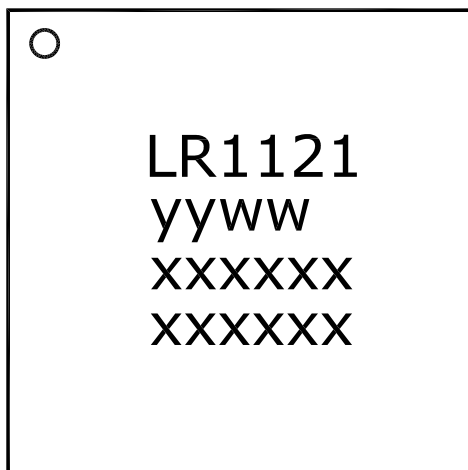

TOP MARK	
CHAR	ROWS
6/6/6/6	4

Marking for the 5 x 5 mm MLPQ 32 Lead package:

nnnnn = Part Number (Example: LR1121)

yyww = Date Code (Example: 2052)

xxxxxx = Semtech Lot No. (Example: E90101

xxxxxx 0101-1)

## 5.3 Land Pattern

Figure 5-3: Land Pattern

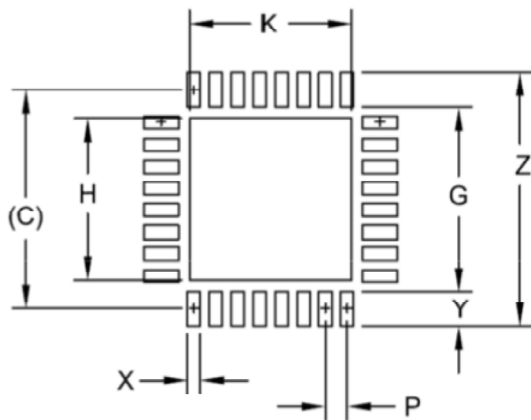

DIMENSIONS		
DIM	INCHES	MILLIMETERS
C	(.197)	(5.00)
G	.165	4.20
H	.146	3.70
K	.146	3.70
P	.020	0.50
X	.012	0.30
Y	.031	0.80
Z	.228	5.80

### NOTES:

1. THIS LAND PATTERN IS FOR REFERENCE PURPOSES ONLY. CONSULT YOUR MANUFACTURING GROUP TO ENSURE YOUR COMPANY'S MANUFACTURING GUIDELINES ARE MET.
2. THERMAL VIAS IN THE LAND PATTERN OF THE EXPOSED PAD SHALL BE CONNECTED TO A SYSTEM GROUND PLANE. FAILURE TO DO SO MAY COMPROMISE THE THERMAL AND/OR FUNCTIONAL PERFORMANCE OF THE DEVICE.
3. SQUARE PACKAGE - DIMENSIONS APPLY IN BOTH " X " AND " Y " DIRECTIONS.

## 5.4 Reflow Profiles

Reflow process instructions are available from the Semtech website, at the following address:  
[http://www.semtech.com/quality/ir\\_reflow\\_profiles.html](http://www.semtech.com/quality/ir_reflow_profiles.html)

The device uses a QFN32 5x5mm package, also named MLP package.

## 5.5 Thermal Information

**Table 5-1: Package Thermal Information**

Name	Value <sup>1</sup>	Unit
Theta j-a, Junction to Ambient	26.7	°C/W

1. As measured on a 4-layer test board with 9 thermal vias, per the Jedec standard

## 5.6 Tape & Reel Information

**Figure 5-4: Tape & Reel Information**

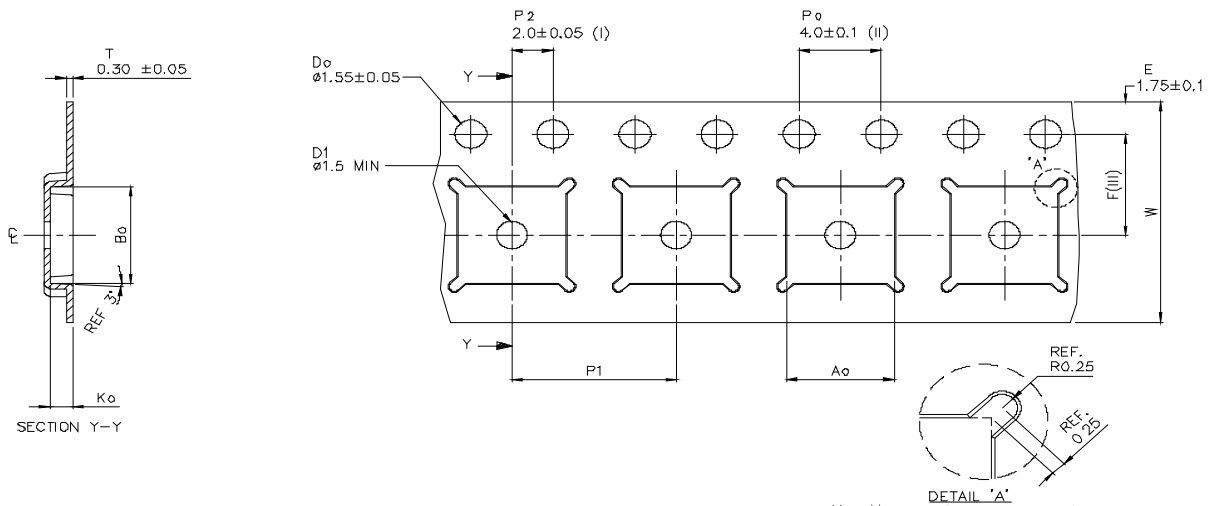

A <sub>0</sub>	5.25 +/− 0.1
B <sub>0</sub>	5.25 +/− 0.1
K <sub>0</sub>	1.10 +/− 0.1
F	5.50 +/− 0.05
P <sub>1</sub>	8.00 +/− 0.1

- DETAIL "A"
- (I) Measured from centreline of sprocket hole to centreline of pocket.
  - (II) Cumulative tolerance of 10 sprocket holes is ± 0.20.
  - (III) Measured from centreline of sprocket hole to centreline of pocket.
  - (IV) Other material available.
  - (V) Typical SR of form tape Max 10<sup>5</sup> DHM/SQ

# Glossary

## List of Acronyms and their Meaning (Sheet 1 of 3)

Acronym	Meaning
ACR	Adjacent Channel Rejection
ADC	Analog-to-Digital Converter
AP	Access Point
API	Application Programming Interface
$\beta$	Modulation Index
BER	Bit Error Rate
BR	Bit Rate
BT	Bandwidth-Time bit period product
BW	BandWidth
CAD	Channel Activity Detection
CPOL	Clock Polarity
CPHA	Clock Phase
CR	Coding Rate
CRC	Cyclical Redundancy Check
CW	Continuous Wave
DC-DC	Direct Current to Direct Current Converter
DIO	Digital Input / Output
DSB	Double Side Band
ECO	Engineering Change Order
FDA	Frequency Deviation
FEC	Forward Error Correction
FIFO	First In First Out
FSK	Frequency Shift Keying
GFSK	Gaussian Frequency Shift Keying
GMSK	Gaussian Minimum Shift Keying
GDPW	Gross Die Per Wafer
IF	Intermediate Frequencies
IRQ	Interrupt Request
ISM	Industrial, Scientific and Medical (radio spectrum)



## List of Acronyms and their Meaning (Sheet 2 of 3)

Acronym	Meaning
LDO	Low-Dropout
LDRO	Low Data Rate Optimization
LFSR	Linear-Feedback Shift Register
LNA	Low-Noise Amplifier
LO	Local Oscillator
LoRa®	Long Range Communication <i>The LoRa® Mark is a registered trademark of the Semtech Corporation</i>
LR-FHSS	Long Range Frequency Hopping Spread Spectrum
LSB	Least Significant Bit
MISO	Master Input Slave Output
MOSI	Master Output Slave Input
MSB	Most Significant Bit
MSK	Minimum-Shift Keying
NOP	No Operation (0x00)
NRZ	Non-Return-to-Zero
NSS	Slave Select active low
OCP	Over Current Protection
PA	Power Amplifier
PER	Packet Error Rate
PHY	Physical Layer
PID	Product Identification
PLL	Phase-Locked Loop
POR	Power On Reset
RC13M	13MHz Resistance-Capacitance Oscillator
RC64k	64kHz Resistance-Capacitance Oscillator
RFO	Radio Frequency Output
RFU	Reserved for Future Use
RTC	Real-Time Clock
SCK	Serial Clock
SF	Spreading Factor
SN	Sequence Number
SNR	Signal to Noise Ratio

---

## List of Acronyms and their Meaning (Sheet 3 of 3)

Acronym	Meaning
SPI	Serial Peripheral Interface
SSB	Single Side Bandwidth
STDBY	Standby
TCXO	Temperature-Compensated Crystal Oscillator
XOSC	Crystal Oscillator



---

#### IMPORTANT NOTICE

Information relating to this product and the application or design described herein is believed to be reliable, however such information is provided as a guide only and Semtech assumes no liability for any errors in this document, or for the application or design described herein. Semtech reserves the right to make changes to the product or this document at any time without notice. Buyers should obtain the latest relevant information before placing orders and should verify that such information is current and complete. Semtech warrants performance of its products to the specifications applicable at the time of sale, and all sales are made in accordance with Semtech's standard terms and conditions of sale.

SEMTECH PRODUCTS ARE NOT DESIGNED, INTENDED, AUTHORIZED OR WARRANTED TO BE SUITABLE FOR USE IN LIFE-SUPPORT APPLICATIONS, DEVICES OR SYSTEMS, OR IN NUCLEAR APPLICATIONS IN WHICH THE FAILURE COULD BE REASONABLY EXPECTED TO RESULT IN PERSONAL INJURY, LOSS OF LIFE OR SEVERE PROPERTY OR ENVIRONMENTAL DAMAGE. INCLUSION OF SEMTECH PRODUCTS IN SUCH APPLICATIONS IS UNDERSTOOD TO BE UNDERTAKEN SOLELY AT THE CUSTOMER'S OWN RISK. Should a customer purchase or use Semtech products for any such unauthorized application, the customer shall indemnify and hold Semtech and its officers, employees, subsidiaries, affiliates, and distributors harmless against all claims, costs damages and attorney fees which could arise.

The Semtech name and logo are registered trademarks of the Semtech Corporation. All other trademarks and trade names mentioned may be marks and names of Semtech or their respective companies. Semtech reserves the right to make changes to, or discontinue any products described in this document without further notice. Semtech makes no warranty, representation or guarantee, express or implied, regarding the suitability of its products for any particular purpose. All rights reserved.

© Semtech2023

---

## Contact Information

Semtech Corporation  
Wireless, Sensing & Timing Products Division  
200 Flynn Road, Camarillo, CA 93012  
Phone: (805) 498-2111, Fax: (805) 498-3804  
[www.semtech.com](http://www.semtech.com)