

ROM + RAM
File: ROM_RAM.kicad_sch

UART + IO
File: UAR_IO.kicad_sch

MC68EC020	
SVDW	
Sheet: /	
File: MC68EC020_SBC.kicad_sch	
Title: EC020-SBC	
Size: A4	Date: 2023-11-23
KiCad E.D.A. kicad 7.0.2-0	Rev: V0.12
	Id: 1/3

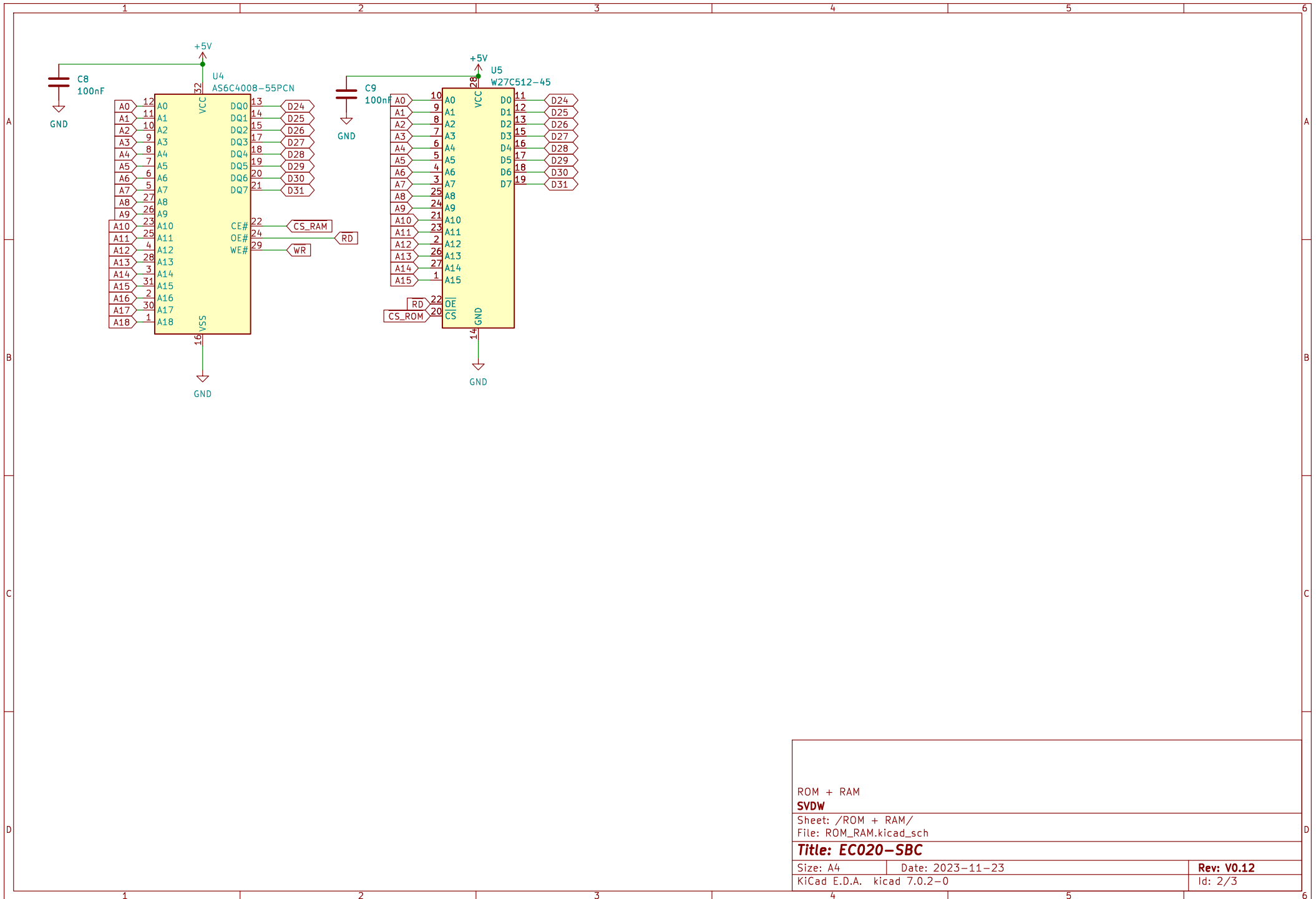

ROM + RAM

SVDW

Sheet: /ROM + RAM/
File: ROM_RAM.kicad_sch

Title: EC020-SBC

Size: A4 Date: 2023-11-23

KiCad E.D.A. kicad 7.0.2-0

Rev: V0.12

Id: 2/3

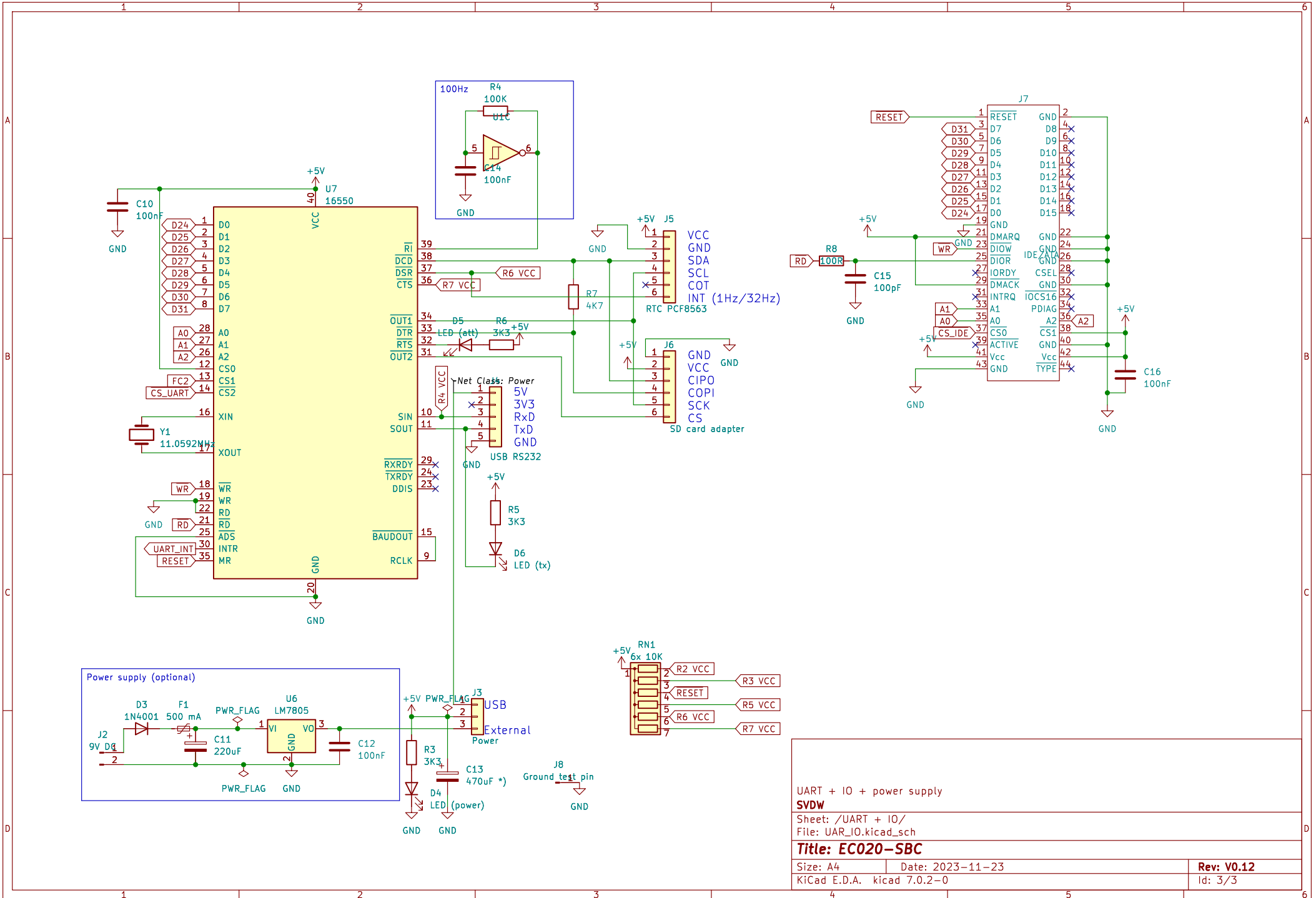

UART + IO + power supply
SVDW
 Sheet: /UART + IO/
 File: UAR_IO.kicad_sch
Title: EC020-SBC
 Size: A4 Date: 2023-11-23
 KiCad E.D.A. kicad 7.0.2-0 **Rev: V0.12**
 Id: 3/3