

**TEAC FD-235HF-A291
MICRO FLOPPY DISK DRIVE**

SPECIFICATION

Rev. A

TABLE OF CONTENTS

Title	Page
1. OUTLINE	1
2. DISK	2
3. PHYSICAL SPECIFICATION	3
4. OPERATIONAL CHARACTERISTICS	5
4.1 2MB Mode Data Capacity	5
4.2 1MB Mode Data Capacity	6
4.3 Disk Rotation Mechanism	6
4.4 Index Detection	7
4.5 Track Construction	7
4.6 Magnetic Head	7
4.7 Track Seek Mechanism	8
4.8 Window Margin and Others	8
5. ENVIRONMENTAL CONDITIONS	9
6. RELIABILITY	10
7. POWER INTERFACE	11
7.1 Required Power	11
7.2 Power Interface Connector and Cable	12
8. SIGNAL INTERFACE	14
8.1 Signal Interface Connector and Cable	14
8.2 Electrical Characteristics	16
8.2.1 FDD side receiver and driver	16
8.2.2 Host side receiver and driver	16
8.3 Input/Output Signals	18
8.3.1 DRIVE SELECT input signal	18
8.3.2 MOTOR ON input signal	18
8.3.3 DIRECTION SELECT input signal	18
8.3.4 STEP input signal	18
8.3.5 WRITE GATE input signal	18
8.3.6 WRITE DATA input signal	19
8.3.7 SIDE ONE SELECT input signal	19
8.3.8 TRACK 00 output signal	19
8.3.9 INDEX output signal	19
8.3.10 READ DATA output signal	20
8.3.11 WRITE PROTECT output signal	20
8.3.12 DISK CHANGE output signal	20
8.3.13 Input/Output signals for density mode setting (HD OUT)	20
8.3.14 NO CONNECTION (NC)	21
8.3.15 Treatment of not-used signals	21
9. CONTROL SEQUENCE	23
9.1 Power-on	23
9.2 Seek Operation	24
9.3 Read Write Operation	25
9.4 Current Consumption Profile	26
10. FRAME GROUNDING	28
11. TURN ON CONDITION OF INDICATOR AND SPINDLE MOTOR	28
11.1 Front Indicator	28

11.2 Spindle Motor	28
--------------------------	----

1. OUTLINE

This specification provides a description for the TEAC FD-235HF, dual density (2/1MB, 2-modes), 3.5-inch micro floppy disk drive (hereinafter referred to as FDD). Table 1-1 shows the outline of the FDD, and Table 1-2 shows the signal interface pin-assignment.

(Table 1-1) Specification outline

Model name	FD-235HF-A291	
Front bezel	Beige (PS)	
Eject button	Beige (PS)	
LED indicator	Green	
Safety standard	UL, CSA & TÜV	
Operation modes	2MB mode Write and read	1MB mode Write and read
3.5 inch disk used	High density (2HD)	Normal density (2DD)
Unformatted data capacity	2M bytes	1M bytes
Data transfer rate	500k bits/s	250k bits/s
Disk rotational speed	300rpm	300rpm
Track density	5.3track/mm (135tpi)	
Track to track time	3ms	
Required power	+5V single (4.5 ~ 5.5V)	
Signal output driver	Open collector TTL	
Input signal pull-up	1kΩ ±30%	
Function setting at delivery	<ol style="list-style-type: none"> 1. Interface setting <ol style="list-style-type: none"> 1.1 Pin12: DRIVE SELECT 1 input 1.2 Pin34: DISK CHANGE output 2. Other function setting <ol style="list-style-type: none"> 2.1 Automatic density setting for 2DD (1MB) disk or 2HD (2MB) disk. 2.2 LED turn on condition: DRIVE SELECT 2.3 Motor rotating condition: MOTOR ON 2.4 Ready and seek-complete gate (full-mask) for INDEX and READ DATA output pulses. 2.5 Auto-chucking at disk installation 2.6 Auto-recalibration at power on 2.7 Frame is electrically shorted to DC 0V. 	
Interface connector	34 pin right-angled header connector	
Power connector	Equipped	
Other optional function	Not equipped	

(Table 1-2) Signal interface pin-assignment

Pin Nos.	Signals	Pin Nos.	Signals	Direc
1	NC	2	NC	–
3	P. key	4	NC	–
5	NC	6	NC	–
7	0V	8	INDEX	Output
9	0V	10	NC	–
11	0V	12	DRIVE SELECT 1	Input
13	0V	14	NC	–
15	0V	16	MOTOR ON	Input
17	0V	18	DIRECTION SELECT	Input
19	0V	20	STEP	Input
21	0V	22	WRITE DATA	Input
23	0V	24	WRITE GATE	Input
25	0V	26	TRACK 00	Output
27	0V	28	WRITE PROTECT	Output
29	0V	30	READ DATA	Output
31	0V	32	SIDE ONE SELECT	Input
33	0V	34	DISK CHANGE	Output

The FDD is equipped with a discrimination switch for the high density (HD) hole of an installed disk cartridge. Refer to item 8.3.13 as to the detailed explanation for density mode setting.

2. DISK

(1) Work disk

3.5-inch micro floppy disks which are mutually agreed between the customer and TEAC.

For 2MB mode : High density disk (2HD)

1MB mode : Normal density disk (2DD)

(2) Cleaning disk

The FDD does not require any cleaning disk. However, the dry type disk which is mutually agreed between the customer and TEAC is used when requiring a cleaning disk.

3. PHYSICAL SPECIFICATION

(Table 3-1) Physical specification

Width	101.6mm (4.00 in), Nom.
Height	25.4mm (1.00 in), Nom.
Depth	145mm (5.71 in), Nom., excluding front bezel
Weight	345g (0.76lbs), Nom., 360g (0.79 lbs), Max.
External view	See fig.3-1.
Cooling	Natural air cooling
Mounting	Mountings for the following directions are acceptable. (a) Front loading, mounted vertically. (b) Front loading, mounted horizontally with spindle motor down. (c) Mounting angle in items (a) and (b) should be less than 25° with front bezel up or down. Note: As to the other mounting directions than the above will be considered separately.
Installation	With installation holes on the frame of the FDD. Refer to Fig.3-1.
Material of frame	Aluminium die-cast
Material of front bezel	PPHOX (Complying with UL94-5V)

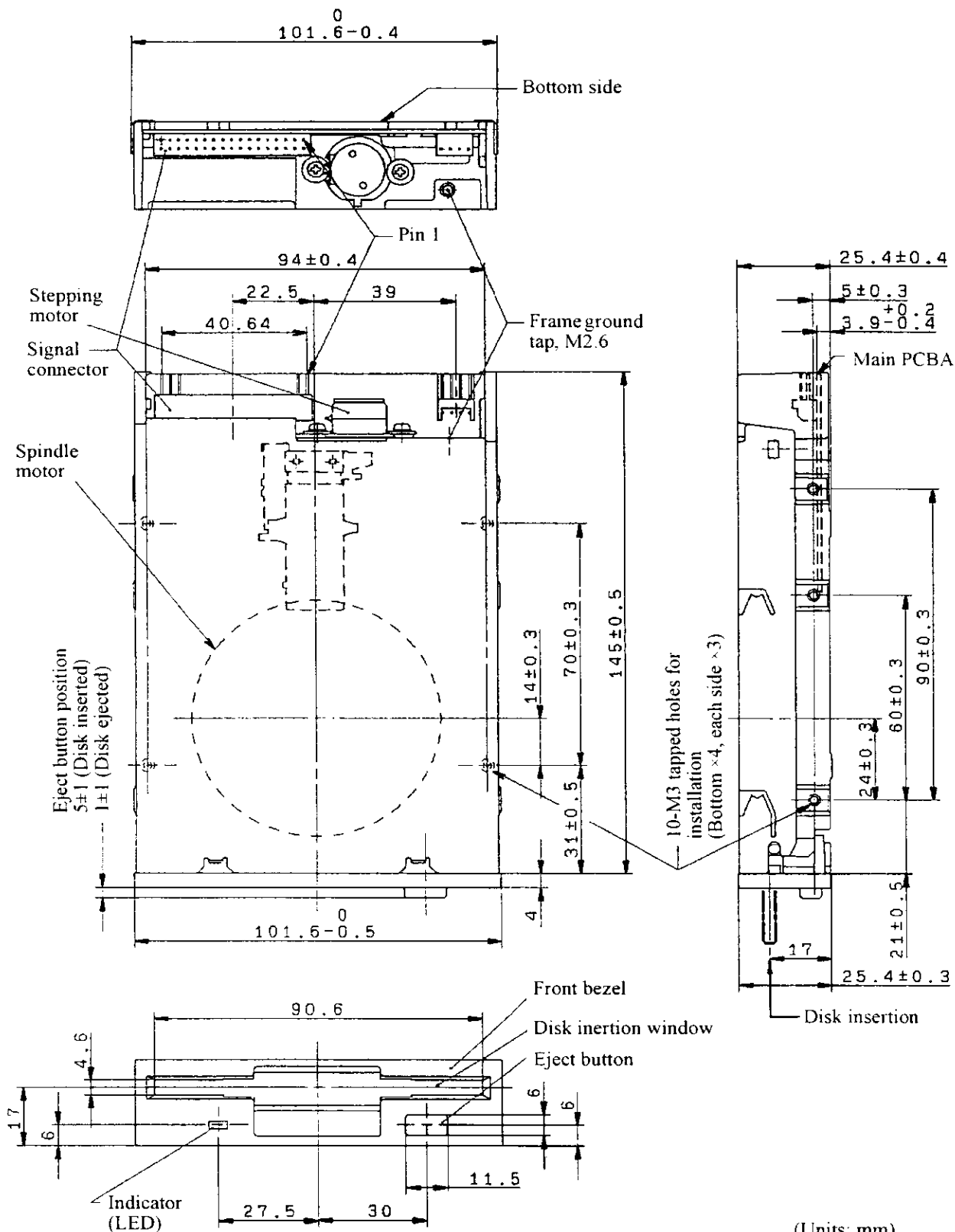

(Fig. 3-1) FDD external view

4. OPERATIONAL CHARACTERISTICS

4.1 2MB Mode Data Capacity

(Table 4.1-1) 2MB mode data capacity

Recording method			FM	MFM	
Data transfer rate (k bits/sec)			250	500	
Tracks/disk			160	160	
Innermost track bit density (bpi)			8,717	17,434	
Innermost track flux density (frpi)			17,434	17,434	
Data capacity	Unformatted		k bytes/track	6.25	12.5
			k bytes/disk	1,000	2,000
	Formatted	32 sectors/track	k bytes/sector	0.128	0.256
			k bytes/track	4.096	8.192
			k bytes/disk	655.36	1,310.72
		18 sectors/track	k bytes/sector	0.256	0.512
			k bytes/track	4.608	9.216
			k bytes/disk	737.28	1,474.56
	10 sectors/track	k bytes/sector	0.512	1.024	
		k bytes/track	5.12	10.24	
		k bytes/disk	819.2	1,638.4	

4.2 1MB Mode Data Capacity

(Table 4.2-1) 1MB mode data capacity

Recording method			FM	MFM	
Data transfer rate (k bits/sec)			125	250	
Tracks/disk			160	160	
Innermost track bit density (bpi)			4,359	8,717	
Innermost track flux density (frpi)			8,717	8,717	
Data capacity	Unformatted	k bytes/track	3.125	6.25	
		k bytes/disk	500	1,000	
	Formatted	16 sectors/track	k bytes/sector	0.128	0.256
			k bytes/trac	2.048	4.096
			k bytes/disk	327.68	655.36
		9 sectors/track	k bytes/sector	0.256	0.512
			k bytes/track	2.304	4.608
			k bytes/disk	368.64	737.28
	5 sectors/track	k bytes/sector	0.512	1.024	
		k bytes/track	2.56	5.12	
		k bytes/disk	409.6	819.2	

4.3 Disk Rotation Mechanism

(Table 4.3-1) Disk Rotation Mechanism

Spindle motor	DC brushless motor
Spindle speed	300rpm
Motor servo method	Frequency servo by ceramic oscillator
Motor/spindle connection	Motor shaft direct
Disk speed	The same as the spindle speed.
Long term speed variation (LSV)	±1.5% or less
Instantaneous speed variation (ISV)	±2% or less
Start time	480ms or less
Average latency	100ms

4.4 Index Detection

(Table 4.4-1) Index Detection

Number of index	1 per disk revolution
Detection method	Rotor detection of spindle motor by Hall element or FG output.
Detection cycle	200ms \pm 1.5%
Index burst detection timing error (with specified test disk)	\pm 400 μ s or less

4.5 Track Construction

(Table 4.5-1) Track Construction

Track density	5.3 tracks/mm (135tpi)
	Track pitch 187.5 μ m
Number of cylinders	80 cylinders
Number of tracks	160 tracks/disk
Outermost track radius (track 00)	Side 0 39.500mm (1.5551 in)
	Side 1 38.000mm (1.4961 in)
Innermost track radius (track 79)	Side 0 24.6875mm (0.9719 in)
	Side 1 23.1875mm (0.9129 in)
Positioning accuracy	\pm 15 μ m or less, with specified test disk (Track 40, 23 \pm 2°C, 45 ~ 55%RH, horizontal)

4.6 Magnetic Head

(Table 4.6-1) Magnetic Head

Magnetic head	Read/write head with erase gap, 2 sets
Effective track width after trim erase	0.115 \pm 0.008mm (0.0045 \pm 0.0003 in)
Read/write gap azimuth error	0° \pm 18', with specified test disk

4.7 Track Seek Mechanism

(Table 4.7-1) Track Seek Mechanism

Head position mechanism	Stepping motor and lead screw
Stepping motor	4-phase, 20 steps per revolution
Stepping motor drive	2 steps per track
Track 00 detection method	Photo-interrupter
Track to track time	3ms (excludes settling time, refer to item 8.3.4)
Settling time	15ms or less (excludes track to track time)
Average track seek time	94ms (includes settling time)

4.8 Window Margin and Others

(Table 4.8-1) Window Margin and Others

Window Margin (with specified test disk, MFM method , PLL separator)	
2MB mode	300ns or more
1MB mode	600ns or more
Recommendable write pre-compensation	
2MB mode	± 125 ns
1MB mode	0 ~ ± 125 ns
Head load mechanism	Not equipped (The FDD becomes head load condition whenever a disk is installed.)
File protect mechanism	Detection of write inhibit hole by switch
Disk detection mechanism	Detection of disk installation by switch
Disk inserting force	6.86N (700g) or less at the center of disk
Disk ejecting force	13.73N (1400g) or less
Acoustic noise at 50cm	50dBA or less at 3ms or 4ms seek operation
Disk type discriminating mechanism	Detection of HD hole by switch
Auto-recalibration	Automatic recalibration to track 00 is executed immediately after power-on.

5. ENVIRONMENTAL CONDITIONS

(Table 5-1) Environmental Condition

	Operating	Storage	Transportation
Ambient temperature	4 ~ 51.7°C (39 ~ 125°F)	-22~60°C (-8 ~ 140°F)	-40 ~ 65°C (-40 ~ 149°F)
Temperature gradient	20°C (36°F) or less per hour	30°C (54°F) or less per hour	30°C (54°F) or less per hour
Relative humidity	20 ~ 80% (no condensation) Max. wet bulb temperature shall be 29.4°C (85°F)	5 ~ 90% (no condensation) Max. wet bulb temperature shall be 40°C (104°F)	5 ~ 95% (no condensation) Max. wet bulb temperature shall be 45°C (113°F)
Vibration	14.7m/s ² (1.5G) or less (10 ~ 100Hz, 1 octave/m sweep rate)	—	19.6m/s ² (2G) or less (10 ~ 100Hz, 1/4 octave/m sweep rate)
	9.8m/s ² (1.0G) or less (100 ~ 200Hz, 1 octave/m sweep rate)		
	4.9m/s ² (0.5G) or less (200 ~ 600Hz, 1 octave/m sweep rate)		
Shock	Write & read: 49m/S ² (5G)(11ms, 1/2 sine wave) or less	—	686m/S ² (70G) (11ms, 1/2 sine wave) or less
	Read only: 98m/S ² (10G)(11ms, 1/2 sine wave) or less	—	
Altitude	-300m (-980feet) ~ 5,000m (16,400feet)	—	
	Notes: The above requirements are applied for the FDD without shipping box. When a long period is required for transportation such as by ship, storage environmental conditions should be applied.		

6. RELIABILITY

(Table 6-1) Reliability

MTTF		30,000 power on hours or more (for typical operation duty)
MTTR		When failure, the FDD should be replaced in unit of the drive and not repaired in unit of parts or assemblies.
Design component life		5 years
Disk life		3×10^6 passes/track or more
Disk insertion		1.5×10^4 times or more
Seek operation		1×10^7 random seeks or more
Preventive maintenance		Not required (for typical operation duty)
Error rate	Soft error	1 or less per 10^9 bits read A soft (recoverable) error means that it can be recovered correctly within three retries.
	Hard error	1 or less per 10^{12} bits read A hard (unrecoverable) error means that it cannot be recovered correctly within three retries. However, it is recommended to be followed by a recalibration to track 00 and four additional retries.
	Seek error	1 or less per 10^6 seeks A seek error means that it can seek to a target track within one retry including a recalibration to track 00.
Safety standard		Approved by UL, CSA and TÜV
Electro-static discharge test		15kV (150pF, 330Ω) No hard error and/or no component damage occur when the test is applied to the operator access area (front bezel area).

7. POWER INTERFACE

7.1 Required Power

The following specifications are applied at interface connector of the FDD.

- (1) DC +12V : Not required
- (2) DC +5V
 - (a) Voltage tolerance : $\pm 10\%$ (4.5 ~ 5.5V)
 - (b) Allowable ripple voltage : 100mVp-p or less (including spike noise)
 - (c) Current and power consumption

(Table 7.1-1) Current and power consumption

Operating mode	Average current		Average power		
	Typ.	Max.	Typ.	Max.	
Stand-by	8mA	10mA	40mW	55mW	
Read operation	0.30A	0.40A	1.50W	2.20W	
Write operation	0.30A	0.40A	1.50W	2.20W	
Seek operation	3ms	0.56A	0.66A	2.80W	3.63W
	6ms	0.60A	0.70A	3.30W	4.18W
Seek operation peak	0.9A	1.0A	4.50W	5.50W	
Spindle motor start	0.62A	0.70A	3.10W	3.85W	

Notes:

1. Values of Typ. current and power are specified at 5.0V, while the values of Max. are at 5.5V (+10%) with a disk of large running torque.
2. Stand-by mode is defined at the stop condition of spindle motor and seek operation.
3. Seek operation peak means the operation during the settling (15ms) after the seek completion.
4. Rush current flows within 150ms after the motor start.
5. Short time peak current except for power-on surge is less than 1.0A.
6. Refer to item 6. 4 as to the current consumption profile.

7.2 Power Interface Connector and Cable

(1) Power interface connector

(Table 7.2-1) Power interface connector

FDD side connector	HONDA TSUSHIN KOGYO Co. Ltd., P/N Z-419E or equivalent
Pin numbers	4 pins
Protection method for mis-connection	Mechanical protection by the shape of connector housing
Connector external view	See Fig.7.2-1.
Connector location	See Fig.3-1.
Power interface connections	See Table 7.2-2.
Cable side matched connector	AMP P/N 171822-4 (natural color) or equivalent
Cable side matched pin	AMP P/N 170204-2 (AWG#20 ~ 26, loose piece) or P/N 170262-2 (AWG#20 ~ 26, strip form) or equivalent

(2) Power interface cable: Any appropriate cables taking the maximum power consumption of the FDD will be acceptable.

(Table 7.2-2) Power interface pin-assignment

Power voltage	Pin numbers
DC +5V	1
0V	2
(0V)	3
(No connection)	4

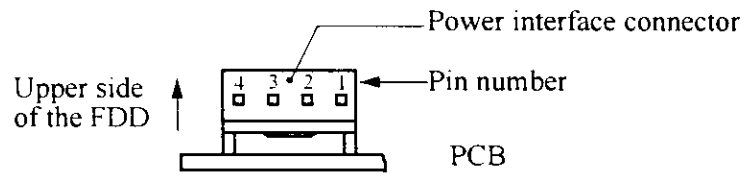

Rear view

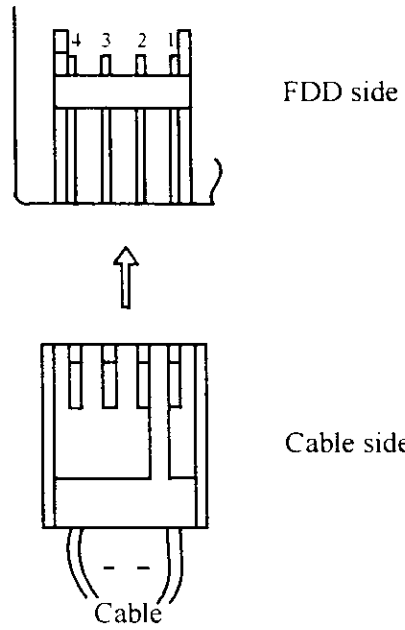

Top view

(Fig. 7.2-1) Power interface connector external view

8. SIGNAL INTERFACE

8.1 Signal Interface Connector and Cable

(1) Signal interface connector

(Table 8.1-1) Signal interface Connector

FDD side connector	FUJITSU, P/N FCN-725P034-AU/A2#32 or equivalent
Pin numbers and pin pitch	2.54mm (0.1 in) pitch, 34-pin block header (17-pin double rows, even number pins are upper side of the FDD).
Connector external view	See Fig.8.1-1.
Connector location	See Fig.3-1.
Cable side matched connector	FUJITSU, P/N FCN-747B034-AU/B (closed end) or -AU/O (daisy chain) or equivalent.

Note: It is recommended to use a polarizing type connector with a projection on the center of the housing to avoid mis-connection. Refer to Fig.8.1-1.

For such a polarizing connector, ▽ mark of the connector housing may show pin No.34.

(2) Signal interface cable Maximum cable length : 2m (6.6 feet), by terminator of 1k Ω or less (For daisy chain connection, the total cable length should be less than 2m).

The longer the cable, the smaller the resistor value should be.

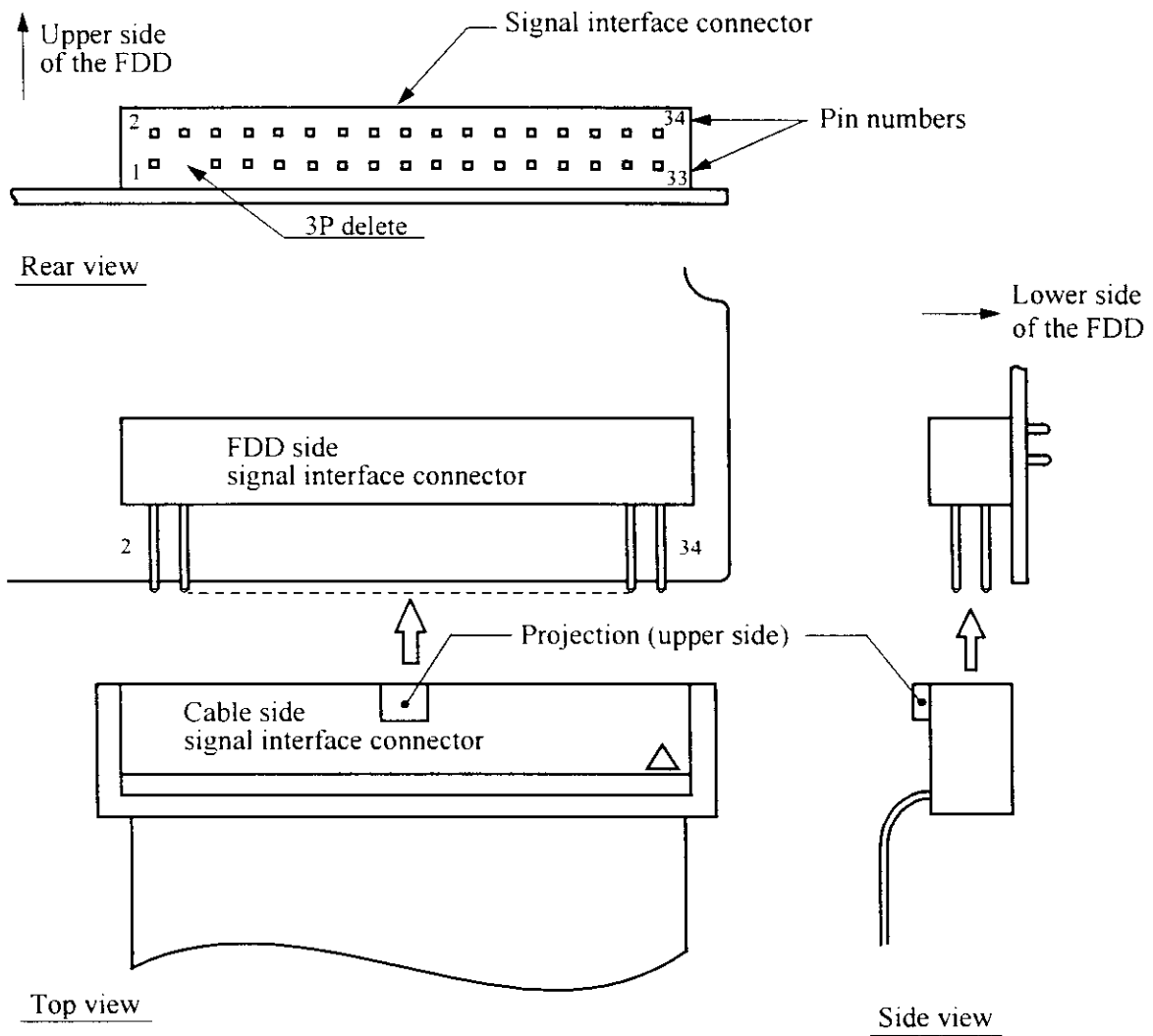

(Fig. 8.1-1) Signal interface connector external view

8.2 Electrical Characteristics

“Vcc” means +5V power voltage supplied to the FDD.

8.2.1 FDD side receiver and driver

The specification are applicable at the interface connector of the FDD.

(Table 8.2-1) FDD side receiver and driver

Interface driver/reciver		See Fig 8.2-1.	
Electrical characteristics of receiver	Input signals (TTL level)	LOW level (TRUE)	0 ~ 0.7V
		LOW level input current	5.9mA, Max. (Including terminator current)
		HIGH level (FALSE)	2.2V ~ +5V power voltage
	Terminator resistor value		1kΩ ±5% Terminator (pull-up) resistor is connected to each input.
Electrical characteristics of driver	Output signals (Open collector driver)	LOW level (TRUE)	0 ~ 0.4V
		Driver sink current capability	37mA, Max.
		HIGH level (FALSE)	Depending on host side terminator

8.2.2 Host side receiver and driver

(Table 8.2-2) Host side receiver and driver

Host side driver	TTL, CMOS, etc.
Driver required sink current	FDD input current × Number of daisy chained FDD
Host side receiver	TTL, CMOS, etc. Terminator is required for each output signal line from the FDD.
Host side terminator resistor value	Usually 1 ~ 2.2kΩ is used. (150Ω Min.)

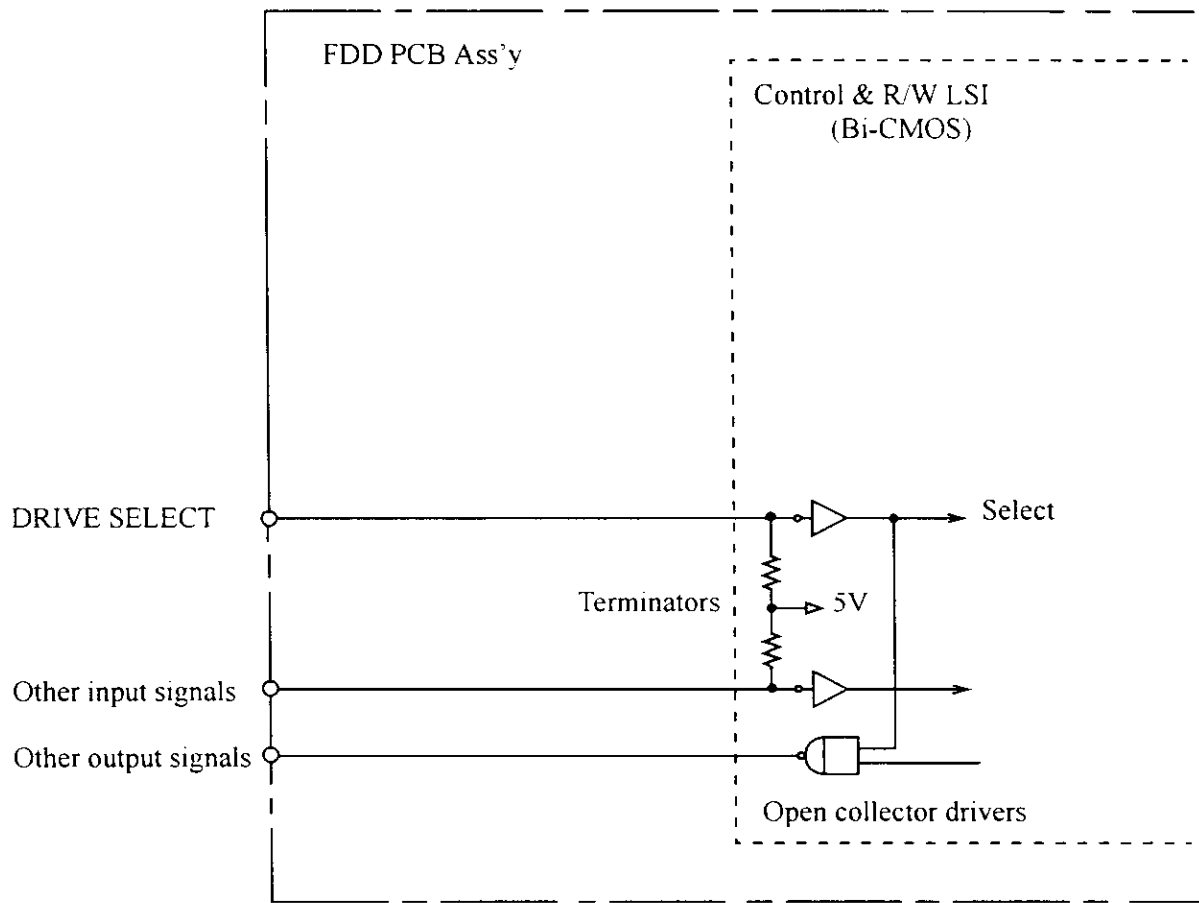

(Fig. 8.2-1) FDD signal interface circuit

8.3 Input/Output Signals

In the following, input signals are those transmitted to the FDD while output signals are those transmitted from the FDD.

LOW level of the signals is TRUE unless otherwise specified.

Refer to Table 1-2 as to the signal needed in this specification.

8.3.1 DRIVE SELECT input signal

- (1) Signal to select a specific FDD for operation in multiplex control.
- (2) All the input/output signals except for the MOTOR ON and MODE SELECT are valid after this signal is made TRUE. The time required to be valid is 0.5 μ sec, Max. including transmission delay time of the DRIVE SELECT signal through the interface cable.
- (3) Refer to item 11.1 as to the turn-on condition of the front bezel indicator.

8.3.2 MOTOR ON input signal

- (1) Level signal to rotate the spindle motor.
- (2) The spindle motor reaches to the rated rotational speed (300rpm) within 480ms after this signal is made TRUE.
- (3) Refer to item 11.2 as to the rotational condition of the spindle motor.

8.3.3 DIRECTION SELECT input signal

- (1) Level signal to define the moving direction of the head when the STEP line is pulsed.
- (2) Step-out (moving away from the center of the disk) is defined as HIGH level of this signal. Conversely, step-in (moving toward the center of the disk) is defined as LOW level of this signal.
- (3) The signal shall maintain its level for 0.8 μ s, Min. prior to the trailing edge of the STEP pulse. Refer to Fig.9.2-1.

8.3.4 STEP input signal

- (1) Negative pulse signal to move the head. The pulse width shall be 0.8 μ s or more and the head moves one track space per one pulse.
- (2) The access motion (head seek operation) is initiated at the trailing edge of the STEP pulse and completes within 18ms after starting the access including the settling time.
- (3) For the subsequent motion in the same direction, the STEP pulses should be input with the interval of 3ms or more, while the pulses should be input with the interval of 4ms or more for a direction change. Refer to Fig.9.2-1.
STEP pulses less than 3ms interval for the same direction or less than 4ms interval for a direction change may cause seek error.
- (4) STEP pulses are ignored and the access motion is not initiated when one of the following conditions is satisfied.
 - (a) The WRITE PROTECT signal is FALSE and the WRITE GATE signal is TRUE.
 - (b) The TRACK 00 signal is TRUE and the DIRECTION SELECT signal is HIGH level (step-out).
 - (c) Step-in operation (DIRECTION SELECT signal is LOW level) from track 81.

8.3.5 WRITE GATE input signal

- (1) Level signal to erase the written data and to enable the writing of new data.
- (2) The FDD is set to write mode when the following logical expression is satisfied.
$$\text{WRITE GATE} * \text{DRIVE SELECT} * \overline{\text{WRITE PROTECT}}$$
- (3) This signal shall be made TRUE after satisfying all of the following conditions.
 - (a) 18ms has been passed after the effective receipt of the final STEP pulse.

- (b) 100 μ s has been passed after the level change of the SIDE ONE SELECT signal.
- (4) The following operations should not be done at least 650 μ s after this signal is changed to FALSE.
 - (a) Make the MOTOR ON signal FALSE.
 - (b) Start the head seek operation by the STEP pulse.
 - (c) Make the DRIVE SELECT signal FALSE.
 - (d) Change the level of the SIDE ONE SELECT signal.

8.3.6 WRITE DATA input signal

- (1) Negative pulse signal to designate the contents of data to be written on a disk. The pulse width should be 0.1 μ s through 1.1 μ s and the leading edge of the pulse is used.
- (2) WRITE DATA pulses are ignored while either of the following conditions is satisfied.
 - (a) The WRITE GATE signal is FALSE.
 - (b) The WRITE PROTECT signal is TRUE.
- (3) This signal should be input according to the timing in Fig 8.3-2.
It is recommended to stop the input of the WRITE DATA pulses during the read operation in order to avoid harmful cross talk.

8.3.7 SIDE ONE SELECT input signal

- (1) Level signal to designate which side of a double sided disk is used for reading or writing.
- (2) When this signal is HIGH level, the magnetic head on the side 0 surface (lower side) of the disk is selected, while the magnetic head on the side 1 surface (upper side) is selected when this signal is LOW level.
- (3) The READ DATA pulse on a selected surface is valid more than 100 μ s after the change of this signal level.
- (4) Write operation (the WRITE GATE signal is TRUE) on a selected surface shall be started more than 100 μ s after the change of this signal level.

8.3.8 TRACK 00 output signal

- (1) Level signal to indicate that the head is on track 00.
- (2) This signal is valid more than 2.8ms, after the effective receipt of the STEP pulse.

8.3.9 INDEX output signal

- (1) Negative pulse signal to indicate the start point of a track and one index pulse per one disk revolution is output.
- (2) INDEX pulse is output when the following logical expression is satisfied.
Index detection * DRIVE SELECT * Ready state * Seek-complete

Notes: (a) Ready state:

- The FDD is powered on.
- A disk is installed.
- Auto-chucking completed.
- A motor-on command is TRUE and 505ms, approx. has been passed.
- An INDEX pulse has been detected after motor-on command.

(b) Seek-complete means the state that 15.8 ~ 17.9ms has been passed after the trailing edge of the final STEP pulse.

- (3) Fig.8.3-1 shows the timing of this signal. Leading edge of the pulse shall be used as the reference and pulse width is 1.5ms through 5ms.

8.3.10 READ DATA output signal

- (1) Negative pulse signal for the read data from a disk composing clock bits and data bits together.
- (2) Fig.8.3-3 shows the timing of this signal. Pulse width is $0.15\mu\text{s}$ through $0.8\mu\text{s}$ and the leading edge of the pulse shall be used as the reference.
- (3) READ DATA pulse is output when the following logical expression is satisfied.

Read data detection * DRIVE SELECT * Write operation * Ready state * Seek-complete

Notes: (a) Refer to item 8.3.9 as to the ready state.

(b) Write operation is the state while the WRITE GATE input signal is FALSE and erase delay time has been passed after the WRITE GATE signal changed to FALSE.

(c) Refer to item 8.3.9 as to the seek-complete.

- (4) Output pulse is valid while all of the following conditions are satisfied.

(a) 18ms has been passed after the effective receipt of the final STEP pulse.

(b) $100\mu\text{s}$ has been passed after the level change of the SIDE ONE SELECT signal.

(c) $650\mu\text{s}$ (2MB mode) or $690\mu\text{s}$ (1MB mode) has been passed after the WRITE GATE signal is changed to FALSE.

8.3.11 WRITE PROTECT output signal

- (1) Level signal to indicate that the write inhibit hole of an installed disk is open.
- (2) When this signal is TRUE, data on the disk are protected from miserasing and write operation is inhibited.

8.3.12 DISK CHANGE output signal

- (1) Level signal to indicate that a disk in the FDD is ejected.
- (2) This signal changes to TRUE when either of the following conditions is satisfied.
 - (a) Power on.
 - (b) A disk is removed.
- (3) The signal returns to FALSE when both of the following conditions are satisfied. Refer to Fig.8.3-4.
 - (a) A disk has been installed.
 - (b) A STEP command is received when the DRIVE SELECT signal is TRUE.

8.3.13 Input/Output signals for density mode setting (HD OUT)

Every FDD model, there are any basic methods for setting the density mode of the FDD as shown in the following.

Use the applicable method for the FDD in contents shown below.

- (1) Method A without using any interface signal (OPEN)
 - (a) Interface signal is not used between the FDD and host-controller.

Density mode of the FDD and host system are determined independently.
 - (b) Density mode of the FDD is automatically set by discriminating the HD hole of an installed disk. If the density mode of the FDD is not coincident with that of the host controller, data errors always occur at read operation.
- (2) Method B using HD OUT output signal
 - (a) Density mode of the FDD is automatically set by discriminating the HD hole of an installed disk.
 - (b) HIGH or LOW level of the HD OUT signal from the FDD is used to inform host controller which type of disk is installed in the FDD. And the density mode of the host is automatically determined according to this signal.
 - (c) Table 8.3.13-1 shows the meaning of the logic level.

(Table 8.3.13-1) Meaning of the logic level

Signal name	Logic level	LOW LEVEL at HIGH DENSITY
HD OUT	HIGH	2DD disk
	LOW	2HD disk

8.3.14 NO CONNECTION (NC)

The NC pins are electrically isolated from any other circuit in the FDD.

8.3.15 Treatment of not-used signals

If some of the provided input/output signals are not necessary for your application, keep the unused signal lines open or pull up by an appropriate resistor value (refer to item 8.2.2) at the host side.

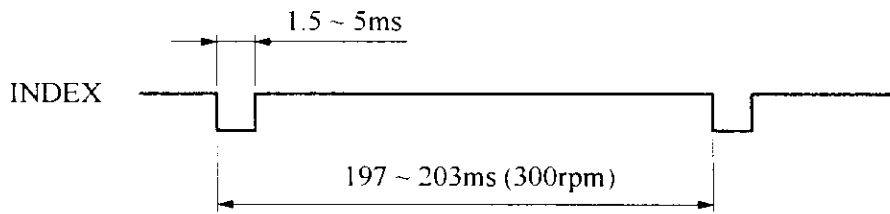

(Fig. 8.3-1) INDEX timing

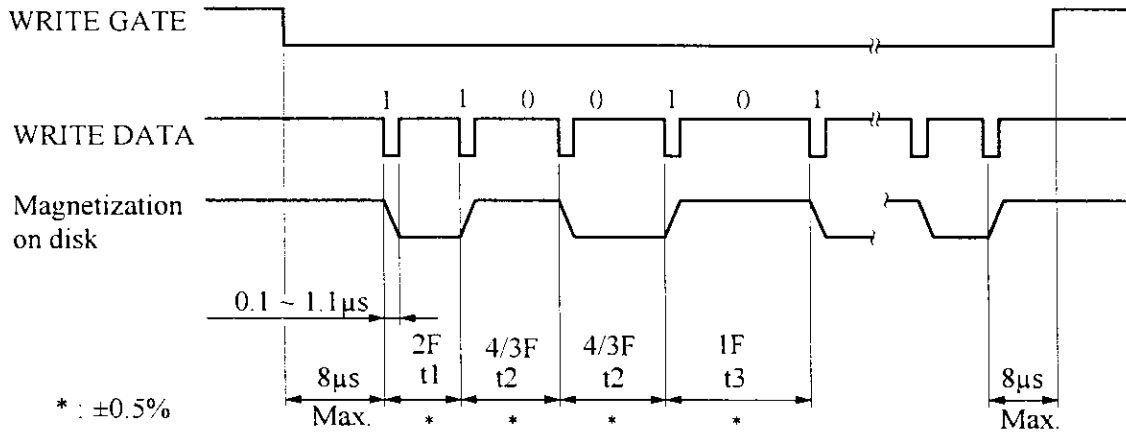

Density mode	rpm	t1	t2	t3
2MB mode	300	2µs, Nom.	3µs, Nom.	4µs, Nom.
1MB mode	300	4µs, Nom.	6µs, Nom.	8µs, Nom.

(Fig. 8.3-2) WRITE DATA timing (MFM method)

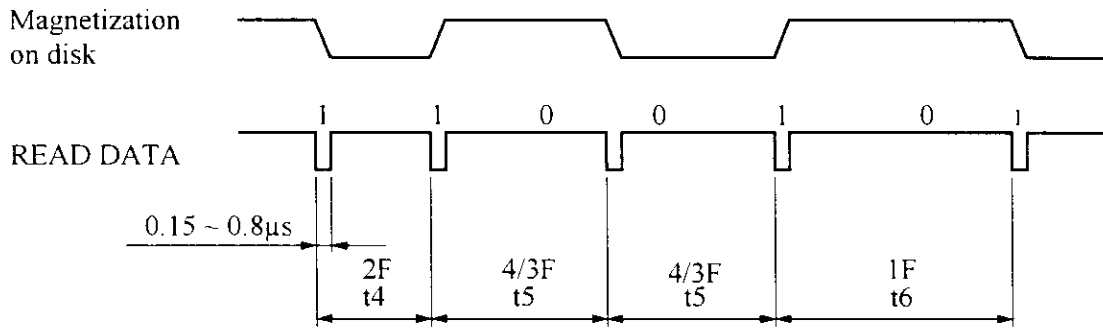

Density mode	rpm	t4	t5	t6	t7
2MB mode	300	2μs, Nom.	3μs, Nom.	4μs, Nom.	±350ns
1MB mode	300	4μs, Nom.	6μs, Nom.	8μs, Nom.	±700ns

(Fig. 8.3-3) READ DATA timing (MFM method)

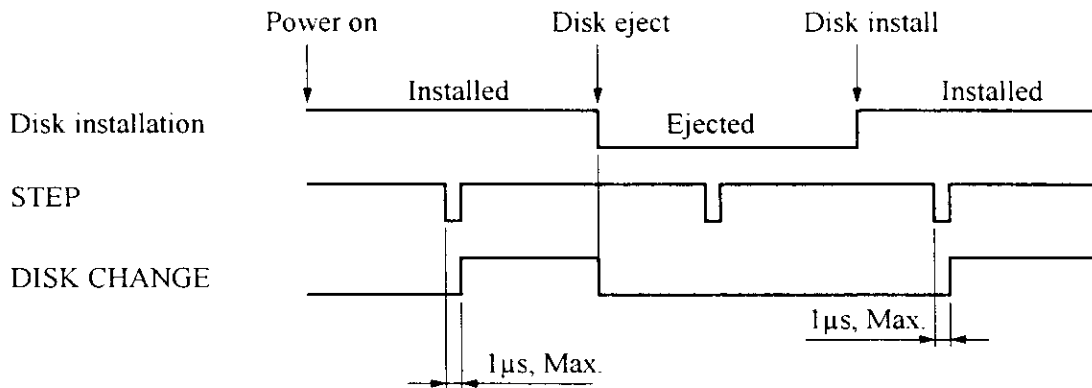

Note: To simplify the timing chart, the DRIVE SELECT signal is assumed always TRUE in the above figure.

(Fig. 8.3-4) DISK CHANGE signal timing

9. CONTROL SEQUENCE

9.1 Power-on

(1) Protection against power on and off

(a) In the transient period when the +5V power is lower than 3.5V, the FDD is protected against miswriting and miserasing whatever the state of input signals are.

(b) Except for the condition of item (a), the FDD is protected against miswriting and miserasing as long as the WRITE GATE input signal does not change to TRUE.

(2) Power reset time in FDD.

Less than 400ms, including auto-recalibration

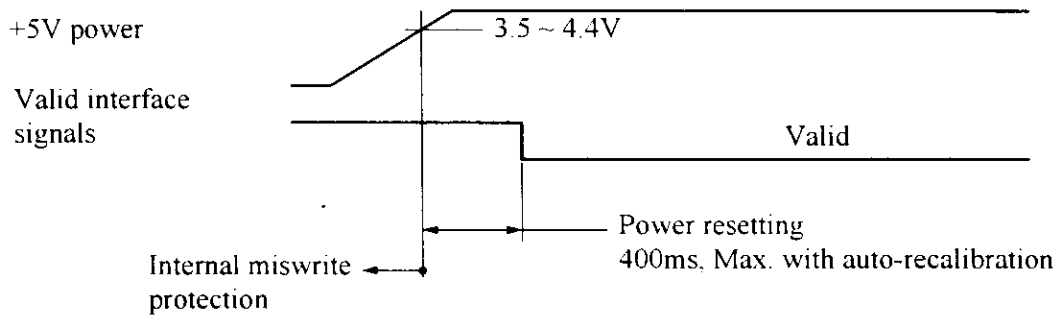

(Fig. 9.1-1) Power on sequence

9.2 Seek Operation

Seek operation can be done independently of the spindle motor rotation.

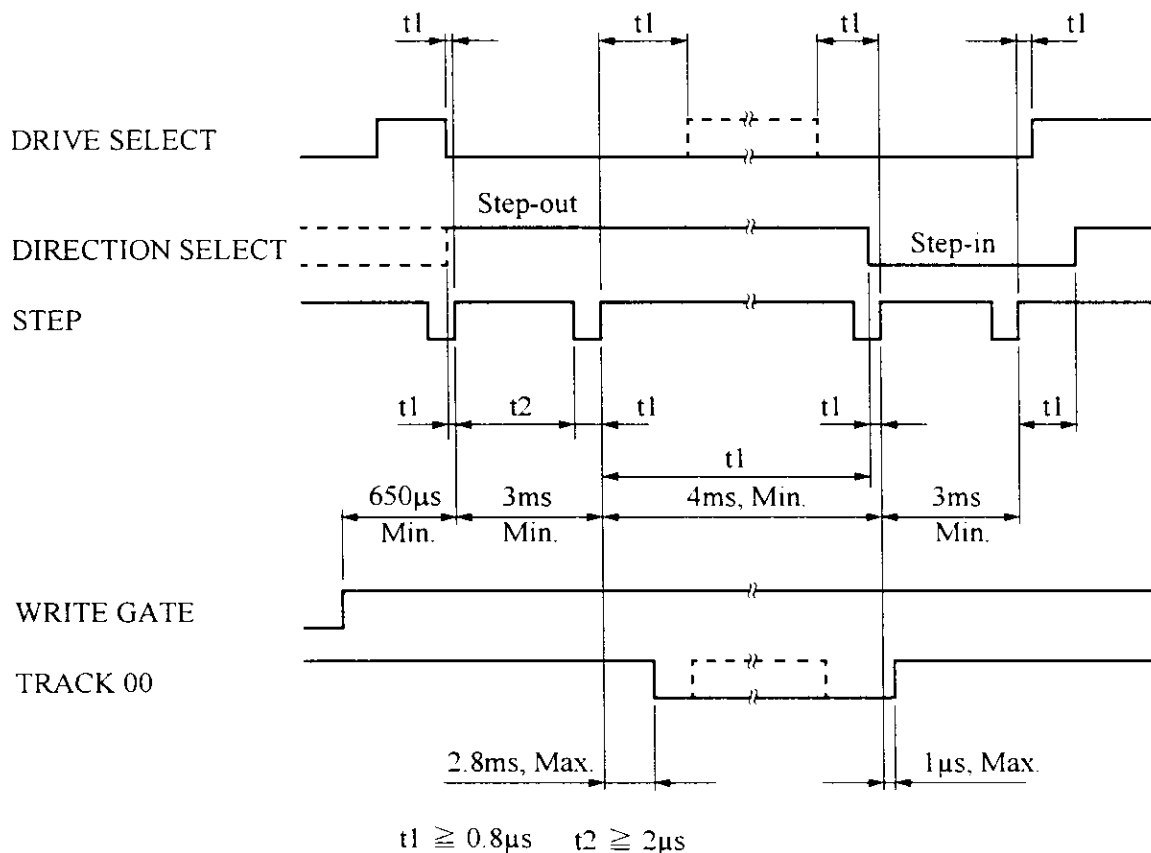

(Fig. 9.2-1) Seek operation timing

9.3 Read Write Operation

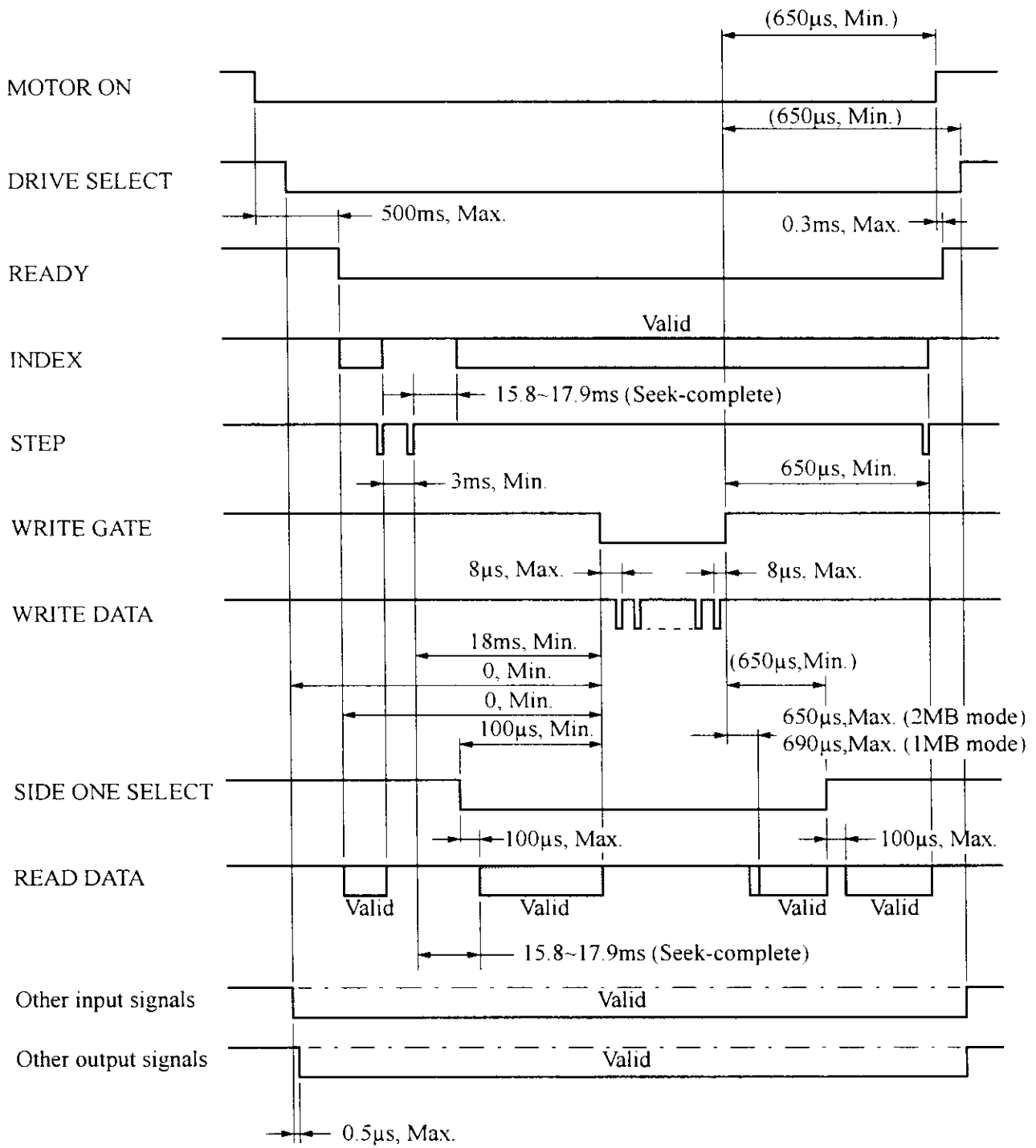

(Fig. 9.3-1) Read/Write operation timing

9.4 Current Consumption Profile

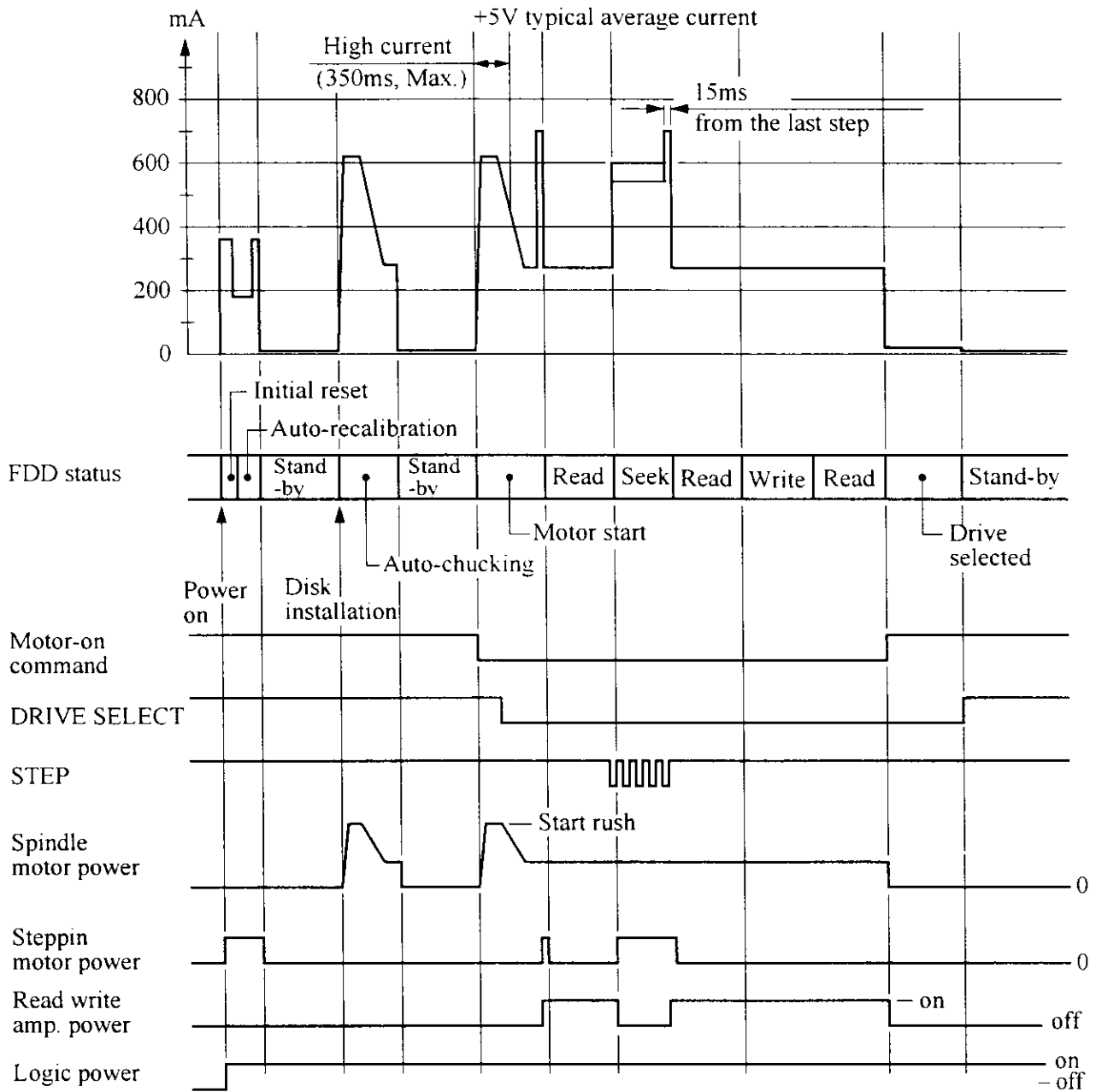

(Fig. 9.4-1) Typical average current profile

(1) Stand-by mode

When both of the following conditions are satisfied, FDD goes to the stand-by mode (low power consumption mode).

(a) The spindle motor stops.

(b) Not in the seek operation (including the settling time).

Note: In the stand-by mode, the FDD can immediately respond to a command from host controller with no restriction.

If the polling operation of the DRIVE SELECT line is done in the stand-by mode, current flows intermittently and +5V current slightly increases.

(2) Simultaneous operation of motor start and seek

If a seek operation is done during the start-up of the spindle motor, or if the motor starts during the seek operation, +5V current at motor start increases by 0.55A, Max. from the value in Table 7.1-1.

Stepping motor is energized at high power from the first STEP to 15msec after the last STEP.

(3) +5V current increases for 15ms after a lapse of 500ms by energizing of the motor.

10. FRAME GROUNDING

The FDD frame is electrically connected to DC 0V by the mounting screw of the main PCBA. (See Fig 10-1).

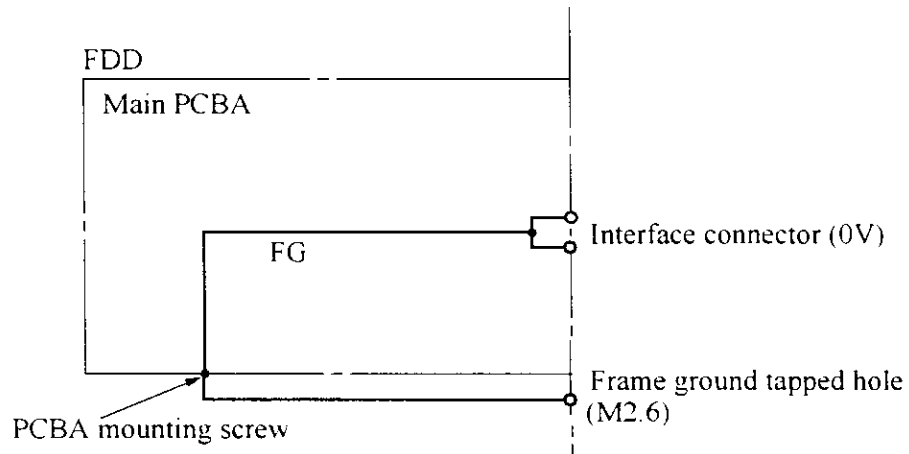

(Fig. 10-1) Frame ground tapped hole

11. TURN ON CONDITION OF INDICATOR AND SPINDLE MOTOR

11.1 Front Indicator

The indicator (LED) turns on while the DRIVE SELECT signal is TRUE. However, the indicator keeps off until 3.1ms has passed after the DRIVE SELECTION to avoid the polling operation of the DRIVE SELECT signal.

11.2 Spindle Motor

- (1) The spindle motor rotates while the MOTOR ON signal is TRUE. While no disk is installed, the spindle motor does not rotate at any condition.
- (2) Auto-chucking operation is executed at each disk installation by rotating the spindle motor for 490ms, approx. (500ms, Max.). All the interface signals are valid according to the explanation in item 8.3 while the auto-chucking operation is in progress.