

Brief Description

The ZSPM4523 is a DC/DC synchronous switching super capacitor charger with fully integrated power switches, internal compensation, and full fault protection. It uses a temperature-independent photo-voltaic maximum power point tracking (MPPT) calculator to optimize power output from the source during Full-Charge Mode. Its 1MHz switching frequency allows using small filter components, which results in smaller board space and reduced bill-of-material costs.

In Full-Charge Mode, the duty cycle is controlled by the MPPT function. Once the termination voltage is reached, the regulator operates in Constant Voltage Mode. When the regulator is disabled (the EN pin is low), the device draws 10µA (typical) quiescent current from V_{OUT}.

The ZSPM4523 integrates a wide range of protection circuitry, including input supply under-voltage lockout, output over-voltage protection, current limiting, and thermal shutdown.

The ZSPM4523 includes supervisory reporting via the NFLT (Inverted Fault) open-drain output to interface other components in the system. Device programming is achieved by the I²C™* interface through the SCL and SDA pins.

Benefits

- Up to 1.5A continuous output current
- High efficiency – up to 92% at typical load

Features

- Temperature-independent MPPT regulation
- V_{OUT} reverse-current blocking
- Programmable temperature-compensated termination voltage: 2.48 to 2.74 V ± 1%
- User programmable maximum charge current: 50mA to 1500mA
- Input supply under-voltage lockout
- Full protection for V_{OUT} over-voltage
- I²C™ program interface with EEPROM registers
- Charge status indication

Related IDT Smart Power Products

- ZSPM4521 High-Efficiency Charger for Li-Ion Batteries with MPPT Regulator
- ZSPM4551 High-Efficiency Charger for Li-Ion Batteries
- ZSPM4121 Ultra-low Power Under-Voltage Switch
- ZSPM4141 Ultra-Low-Power Linear Regulator

Available Support

- Evaluation Kit
- Support Documentation

Physical Characteristics

- Wide input voltage range: 3.2V to 7.2V
- Junction operating temperature -40°C to 125°C
- Packaged in a 16-pin PQFN (4mm x 4mm)

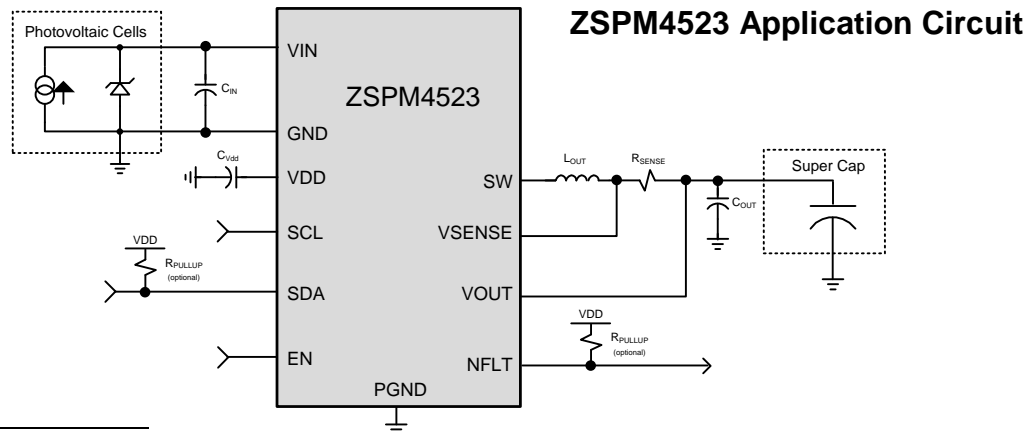

* I²C™ is a trademark of NXP.

ZSPM4523 Block Diagram

- Typical Applications**
- Portable solar chargers
 - Off-grid systems
 - Wireless sensor networks

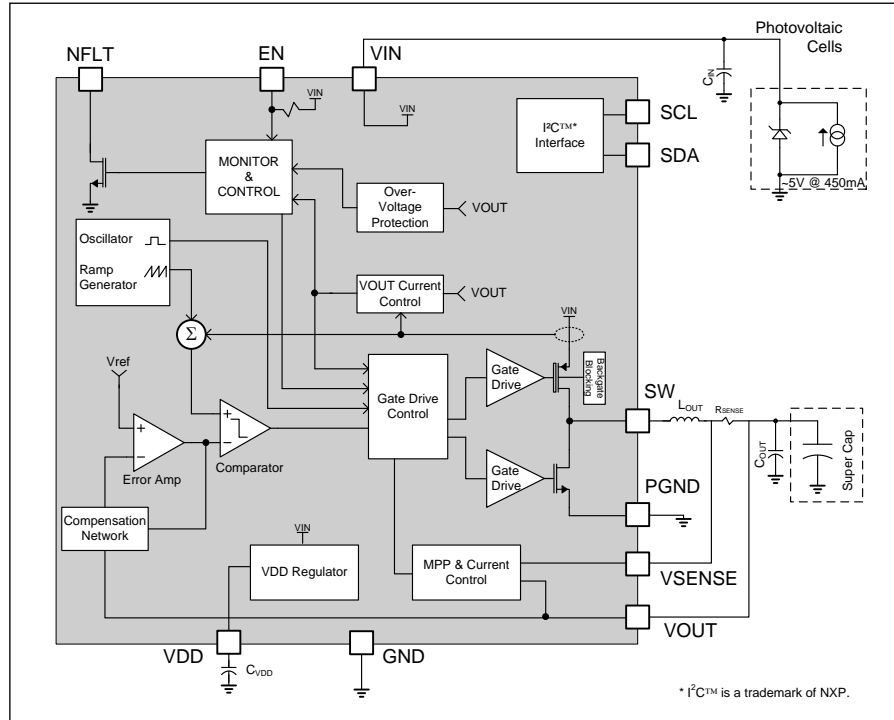

Ordering Information

Ordering Code	Description	Package
ZSPM4523AA1W	ZSPM4523 High-Efficiency Regulator for Super Cap Systems	16-pin PQFN / 7" Reel (1000 parts)
ZSPM4523AA1R	ZSPM4523 High-Efficiency Regulator for Super Cap Systems	16-pin PQFN / 13" Reel (3300 parts)
ZSPM4523KIT	ZSPM4523 Evaluation Kit	



Corporate Headquarters
 6024 Silver Creek Valley Road
 San Jose, CA 95138
www.IDT.com

Sales
 1-800-345-7015 or 408-284-8200
 Fax: 408-284-2775
www.IDT.com/go/sales

Tech Support
www.IDT.com/go/support

DISCLAIMER Integrated Device Technology, Inc. (IDT) reserves the right to modify the products and/or specifications described herein at any time, without notice, at IDT's sole discretion. Performance specifications and operating parameters of the described products are determined in an independent state and are not guaranteed to perform the same way when installed in customer products. The information contained herein is provided without representation or warranty of any kind, whether express or implied, including, but not limited to, the suitability of IDT's products for any particular purpose, an implied warranty of merchantability, or non-infringement of the intellectual property rights of others. This document is presented only as a guide and does not convey any license under intellectual property rights of IDT or any third parties.

IDT's products are not intended for use in applications involving extreme environmental conditions or in life support systems or similar devices where the failure or malfunction of an IDT product can be reasonably expected to significantly affect the health or safety of users. Anyone using an IDT product in such a manner does so at their own risk, absent an express, written agreement by IDT.

Integrated Device Technology, IDT and the IDT logo are trademarks or registered trademarks of IDT and its subsidiaries in the United States and other countries. Other trademarks used herein are the property of IDT or their respective third party owners. For datasheet type definitions and a glossary of common terms, visit www.idt.com/go/glossary. All contents of this document are copyright of Integrated Device Technology, Inc. All rights reserved.

Contents

1	ZSPM4523 Characteristics.....	5
1.1.	Absolute Maximum Ratings.....	5
1.2.	Thermal Characteristics.....	5
1.3.	Recommended Operating Conditions	6
1.4.	Electrical Characteristics	6
1.5.	I ² C™ Interface Timing Requirements.....	9
2	Functional Description.....	10
2.1.	Internal Protection Features	11
2.1.1.	VIN Under-Voltage Lockout	11
2.1.2.	Internal Current Limit	11
2.1.3.	Thermal Shutdown	11
2.1.4.	VOU Over-Voltage Protection.....	11
3	Serial Interface	12
3.1.	I ² C™ Subaddress Definition	12
3.2.	I ² C™ Bus Operation	12
3.3.	Status and Configuration Registers.....	14
4	Application Circuits.....	17
4.1.	Typical Application Circuits.....	17
4.2.	Selection of External Components	17
4.2.1.	C _{OUT} Output Capacitor	17
4.2.2.	L _{OUT} Output Inductor	17
4.2.3.	C _{IN} Bypass Capacitor for Input from Photovoltaic Source	17
4.2.4.	C _{VDD} Bypass Capacitor for VDD Internal Reference Voltage Output	17
4.2.5.	R _{SENSE} Output Sensing Resistor	18
4.2.6.	Pull-up Resistors	18
5	Pin Configuration and Package.....	18
5.1.	ZSPM4523 Package Dimensions.....	18
5.2.	Pin Assignments.....	19
5.3.	Pin Description.....	19
5.4.	Package Markings	20
6	Layout Recommendations.....	21
6.1.	Multi-Layer PCB Layout.....	21
6.2.	Single-Layer PCB Layout	22
7	Ordering Information	23
8	Related Documents.....	23
9	Document Revision History.....	24

List of Figures

Figure 2.1	ZSPM4523 Block Diagram	10
Figure 3.1	Subaddress in I ² C™ Transmission.....	12
Figure 3.2	I ² C™ STOP/START Protocol	13
Figure 3.3	I ² C™ Data Transmission Timing	13
Figure 4.1	Application Circuit	17
Figure 5.1	PQFN-16 Package Dimensions.....	18
Figure 5.2	ZSPM4523 Pin Assignments for 16-Pin 4mm x4mm PQFN	19
Figure 6.1	Package and PCB Land Configuration for Multi-Layer PCB	21
Figure 6.2	JEDEC Standard FR4 Multi-Layer Board – Cross-Sectional View.....	21
Figure 6.3	Conducting Heat Away from the Die using an Exposed Pad Package	22
Figure 6.4	Application Using a Single-Layer PCB	23

List of Tables

Table 1.1	Absolute Maximum Ratings	5
Table 1.2	Thermal Characteristics.....	5
Table 1.3	Recommended Operating Conditions	6
Table 1.4	Electrical Characteristics	6
Table 1.5	I ² C™ Interface Timing Characteristics.....	9
Table 3.1	Register Description (Device Address = 48 _{HEX}).....	14
Table 3.2	STATUS Register—Address 00 _{HEX}	14
Table 3.3	Configuration Register CONFIG1—Address 02 _{HEX}	15
Table 3.4	Configuration Register CONFIG3—Address 04 _{HEX}	15
Table 3.5	Enable Configuration Register CONFIG_ENABLE—Address 11 _{HEX}	16
Table 3.6	EEPROM Control Register EEPROM_CTRL—Address 12 _{HEX}	16
Table 5.1	ZSPM4523 Pin Description.....	19

1 ZSPM4523 Characteristics

Important: Stresses beyond those listed under “Absolute Maximum Ratings” (section 1.1) might cause permanent damage to the device. These are stress ratings only, and functional operation of the device at these or any other conditions beyond those indicated under “Thermal Characteristics” (section 1.2) and “Recommended Operating Conditions” (section 1.3) is not implied. Exposure to absolute–maximum–rated conditions for extended periods might affect device reliability.

1.1. Absolute Maximum Ratings

Over operating free–air temperature range unless otherwise noted.

Table 1.1 Absolute Maximum Ratings

Parameter	Value ¹⁾	Unit
VIN, EN, NFLT, SCL, SDA, VOUT, VSENSE	-0.3 to 8	V
SW	-1 to 8.8	V
VDD	-0.3 to 3.6	V
Operating Junction Temperature Range, T _J	-40 to 125	°C
Storage Temperature Range, T _{STOR}	-65 to 150	°C
Electrostatic Discharge – Human Body Model ²⁾	+/-2k	V
Electrostatic Discharge – Machine Model ²⁾	+/-200	V
Lead Temperature (soldering, 10 seconds)	260	°C
1) All voltage values are with respect to network ground terminal. 2) ESD testing is performed according to the respective JESD22 JEDEC standard.		

1.2. Thermal Characteristics

Table 1.2 Thermal Characteristics

Parameter	Symbol	Value	Unit
Thermal Resistance Junction to Air ¹⁾	θ_{JA}	50	°C/W
1) Assumes 4x4mm QFN-16 in 1 in ² area of 2 oz. copper and 25°C ambient temperature.			

1.3. Recommended Operating Conditions

Table 1.3 Recommended Operating Conditions

Parameter	Symbol	Min	Typ	Max	Unit
Photovoltaic Input Operating Voltage	V_{IN}	3.2	5.3	7.2	V
Sense Resistor	R_{SENSE}		50		m Ω
Output Filter Inductor Typical Value ¹⁾	L_{OUT}		4.7		μ H
Output Filter Capacitor Typical Value ²⁾	C_{OUT}		4.7		μ F
Output Filter Capacitor ESR	$C_{OUT-ESR}$			100	m Ω
Input Supply Bypass Capacitor Typical Value ³⁾	C_{IN}	3.3	10		μ F
VDD Supply Bypass Capacitor Value ²⁾	C_{VDD}	70	100	130	nF
Operating Free Air Temperature	T_A	-40		85	$^{\circ}$ C
Operating Junction Temperature	T_J	-40		125	$^{\circ}$ C

1) For best performance, use an inductor with a saturation current rating higher than the maximum V_{OUT} load requirement plus the inductor current ripple.
 2) For best performance, use a low ESR ceramic capacitor.
 3) For best performance, use a low ESR ceramic capacitor. If C_{IN} is not a low ESR ceramic capacitor, add a 0.1 μ F ceramic capacitor in parallel to C_{IN} .

1.4. Electrical Characteristics

Electrical Characteristics, $T_J = -40^{\circ}\text{C}$ to 125°C , $V_{IN} = 5.3\text{V}$ (unless otherwise noted).

Table 1.4 Electrical Characteristics

Parameter	Symbol	Condition	Min	Typ	Max	Unit
VIN Supply Voltage						
Photovoltaic Voltage Input	V_{IN}		3.2	5.3	7.2	V
Quiescent Current Normal Mode	$I_{CC-NORM}$	$I_{LOAD} = 0\text{A}$, $EN \geq 2.2\text{V}$ (HIGH)		3		mA
Quiescent Current Disabled Mode	$I_{CC-DISABLE}$	$EN = 0\text{V}$		10	50	μ A
VOUT Leakage						
Leakage Current From Output	$I_{OUT-LEAK}$	$EN = 0\text{V}$, $V_{OUT} = 2.7\text{V}$			10	μ A
Reverse Current	$I_{OUT-BACK}$	$V_{OUT} > V_{IN}$, $V_{OUT} = 2.7\text{V}$			10	μ A

Parameter	Symbol	Condition	Min	Typ	Max	Unit
VIN Under-Voltage Lockout						
Input Supply Under Voltage Threshold	V_{IN-UV}	V_{IN} increasing		3.15		V
Input Supply Under Voltage Threshold Hysteresis	V_{IN-UV_HYST}		100	200		mV
OSC						
Oscillator Frequency	f_{OSC}		0.9	1	1.1	MHz
NFLT Open Drain Output						
High-Level Output Leakage	$I_{OH-NFLT}$	$V_{NFLT} = 5.3V$		0.1		μA
Low-Level Output Voltage	$V_{OL-NFLT}$	$I_{NFLT} = -1mA$			0.4	V
EN/SCL/SDA Input Voltage Thresholds						
High Level Input Voltage	V_{IH}		2.2			V
Low Level Input Voltage	V_{IL}				0.8	V
Input Hysteresis – EN, SCL, SCA Pins	V_{HYST}			200		mV
Input Leakage – EN Pin	I_{IN-EN}	$V_{EN}=VIN$		0.1		μA
		$V_{EN}=0V$		-2.0		μA
Input Leakage – SCL Pin	I_{IN-SCL}	$V_{SCL}=VIN$		55		μA
		$V_{SCL}=0V$		-0.1		μA
Input Leakage – SDA Pin	I_{IN-SDA}	$V_{SDA}=VIN$		0.1		μA
		$V_{SDA}=0V$		-0.1		μA
Low-Level Output Voltage	V_{OL-SDA}	$I_{SDA} = -1mA$			0.4	V
Thermal Shutdown						
Thermal Shutdown Junction Temperature	T_{SD}		150	170		$^{\circ}C$
TSD Hysteresis	$T_{SD-HYST}$			10		$^{\circ}C$

Parameter	Symbol	Condition	Min	Typ	Max	Unit
Charging Regulator with $L_{OUT}=4.7\mu\text{H}$ and $C_{OUT}=4.7\mu\text{F}$						
Output Current Limit in Full Charge Mode	I_{OUT-FC}	I_{OUT} is user programmable; see Table 3.4.	$I_{OUT} - 5\%$	I_{OUT}	$I_{OUT} + 5\%$	A
Termination Voltage	V_{OUT}	V_{OUT} is user-programmable; see Table 3.3.	$V_{OUT} - 1\%$	V_{OUT}	$V_{OUT} + 1\%$	V
Full Charge Timer	t_{FC}		200		1400	min
High-Side (HS) Switch On Resistance	R_{DSON}	$I_{SW} = -1\text{A}, T_J=25^\circ\text{C}$		250		$\text{m}\Omega$
Low-Side (LS) Switch On Resistance		$I_{SW} = 1\text{A}, T_J=25^\circ\text{C}$		150		$\text{m}\Omega$
Output Current	I_{OUT}				1.5	A
Over-Current Detect	I_{OCD}	HS switch current		2.5		A
V_{OUT} Over-Voltage Threshold	V_{OUT-OV}		101% V_{OUT}	102% V_{OUT}	103% V_{OUT}	
V_{OUT} Over-Voltage Hysteresis	$V_{OUT-OV-HYS}$		0.2% V_{OUT}	0.4% V_{OUT}	0.6% V_{OUT}	
Maximum Duty Cycle	$DUTY_{MAX}$			98		%

1.5. I²C™ Interface Timing Requirements

Electrical characteristics $T_J = -40^{\circ}\text{C}$ to 125°C , $V_{IN} = 5.3\text{V}$. See Figure 3.3 for an illustration of the timing specifications given in Table 1.5.

Table 1.5 I²C™ Interface Timing Characteristics

Parameter	Symbol	Standard Mode		Fast Mode ¹⁾		Unit
		Min	Max	Min	Max	
I ² C™ Clock Frequency	f_{scl}	0	100	0	400	kHz
I ² C™ Clock High Time	t_{sch}	4		0.6		μs
I ² C™ Clock Low Time	t_{scl}	4.7		1.3		μs
I ² C™ Tolerable Spike Time ²⁾	t_{sp}	0	50	0	50	ns
I ² C™ Serial Data Setup Time	t_{sds}	250		100		ns
I ² C™ Serial Data Hold Time	t_{sdh}	0		0		μs
I ² C™ Input Rise Time ²⁾	t_{icr}		1000		300	ns
I ² C™ Input Fall Time ²⁾	t_{icf}		300		300	ns
I ² C™ Output Fall Time; 10pF to 400pF Bus ²⁾	t_{ocf}		300		300	ns
I ² C™ Bus Free Time Between Stop and Start	t_{buf}	4.7		1.3		μs
I ² C™ Start or Repeated Start Condition Setup Time	t_{sts}	4.7		0.6		μs
I ² C™ Start or Repeated Start Condition Hold Time	t_{sth}	4		0.6		μs
I ² C™ Stop Condition Setup Time ²⁾	t_{sps}	4		0.6		μs

1) The I²C™ interface will operate in either standard or fast mode.
 2) Parameter not tested in production.

2 Functional Description

The ZSPM4523 is a fully-integrated super capacitor charger IC based on a highly-efficient switching topology. It includes a maximum power point tracking (MPPT) function to optimize its input voltage to extract the maximum possible power from a photovoltaic cell. It includes configurability for termination voltage and charge current. A 1MHz internal switching frequency facilitates low-cost LC filter combinations.

When enabled, the ZSPM4523 will provide the maximum power available from a photovoltaic cell (Full-Charge Mode) until the output voltage reaches its termination point. At that point, it will begin to regulate voltage (Constant Voltage Mode). It will do so until a fault is detected, it is disabled, or the output voltage drops below the termination point.

Figure 2.1 ZSPM4523 Block Diagram

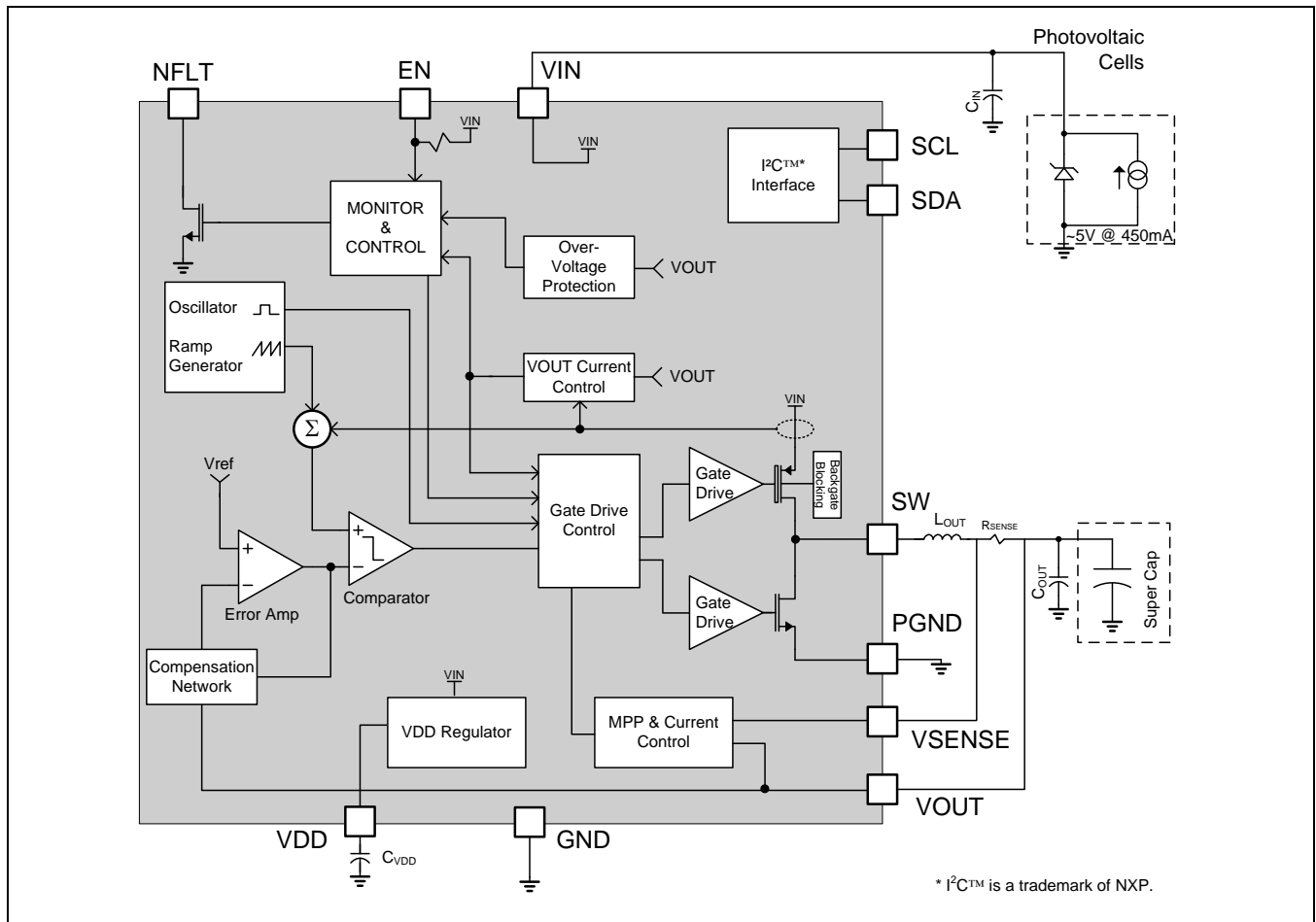

2.1. Internal Protection Features

2.1.1. VIN Under-Voltage Lockout

The device is held in the off state until the EN pin voltage is HIGH ($\geq 2.2\text{V}$) and VIN rises to 3.15V (typical). There is a 200mV (typical) hysteresis on this input, which requires the input to fall below 2.95V (typical) before the device will disable.

2.1.2. Internal Current Limit

The current through the L_{OUT} inductor is sensed on a cycle-by-cycle basis, and if the current limit (I_{OCD} , see section 1.4) is reached, it will abbreviate the cycle. Current limit is always active when the regulator is enabled.

2.1.3. Thermal Shutdown

If the junction temperature of the ZSPM4523 exceeds 170°C (typical), the SW output will tri-state to protect the device from damage. The NFLT and all other protection circuitry will stay active to inform the system of the failure mode. Once the device cools to 160°C (typical), the device will attempt to start up again. If the device reaches 170°C, the shutdown/restart sequence will repeat.

2.1.4. VOUT Over-Voltage Protection

The ZSPM4523 has an output protection circuit designed to shut down the charging profile if the output voltage is greater than the termination voltage. The termination voltage can be selected by user programming, so the protection threshold is set to 2% above the termination voltage. Shutting down the charging profile puts the ZSPM4523 in a fault condition.

3 Serial Interface

The ZSPM4523 features an I²C™ slave interface that offers advanced control and diagnostic features. It supports standard and fast mode data rates and auto-sequencing, and it is compliant to I²C™ standard version 3.0.

I²C™ operation offers configuration control for termination voltages, charge currents, and charge timeouts. This configurability allows optimum charging conditions. I²C™ operation also offers fault and warning indicators. Whenever a fault is detected, the associated status bit in the STATUS register is set and the NFLT pin is pulled low. If a warning is detected, the associated status bit in the STATUS register is set, but the NFLT pin is not pulled low. (See Table 3.2.) Reading of the STATUS register resets the fault and warning status bits, and the NFLT pin is released after all fault status bits have been reset.

3.1. I²C™ Subaddress Definition

Figure 3.1 Subaddress in I²C™ Transmission

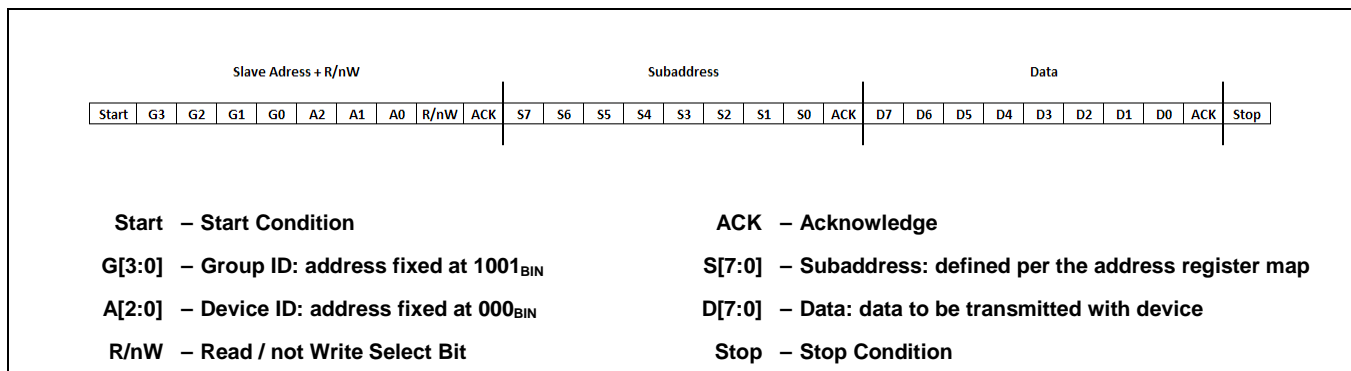

3.2. I²C™ Bus Operation

The ZSPM4523's I²C™ bus is a two-wire serial interface; the two lines are serial clock (SCL) and serial data (SDA) (see Figure 3.2). SDA must be connected to a positive supply (e.g., the VDD pin) through an external pull-up resistor. The devices communicating on this bus can drive the SDA line low or release it to high impedance. To ensure proper operation, setup, and hold times must be met. The device that initiates the I²C™ transaction becomes the master of the bus.

Communication is initiated by the master sending a START condition, which is a high-to-low transition on SDA while the SCL line is high. After the START condition, the device address byte is sent, most significant bit (MSB) first, including the data direction bit (read = 1; write = 0). After receiving the valid address byte, the device responds with an acknowledge (ACK). An ACK is a low on SDA during the high of the ACK-related clock pulse. On the I²C™ bus, during each clock pulse only one data bit is transferred. The data on the SDA line must remain stable during the high pulse of the clock period, as changes in the data line at this time are interpreted as START or STOP control commands. A low-to-high transition on SDA while the SCL input is high indicates a STOP condition and is sent by the master (see Figure 3.2).

Any number of data bytes can be transferred from the transmitter to receiver between the START and the STOP conditions. Each byte of eight bits is followed by one ACK bit from the receiver. The SDA line must be released by the transmitter before the receiver can send an ACK bit. The receiver that acknowledges must pull down the SDA line during the ACK clock pulse, so that the SDA line is stable low during the high pulse of the ACK-related clock period. When a slave receiver is addressed, it must generate an ACK after each byte is received. Similarly, the master must generate an ACK after each byte that it receives from the slave transmitter. An end of data is signaled by the master receiver to the slave transmitter by not generating an acknowledge after the last byte has been clocked out of the slave. This is done by the master receiver by holding the SDA line high. The transmitter must then release the data line to enable the master to generate a STOP condition.

See section 1.5 for the timing for the periods labeled in Figure 3.3.

Figure 3.2 I²C™ STOP/START Protocol

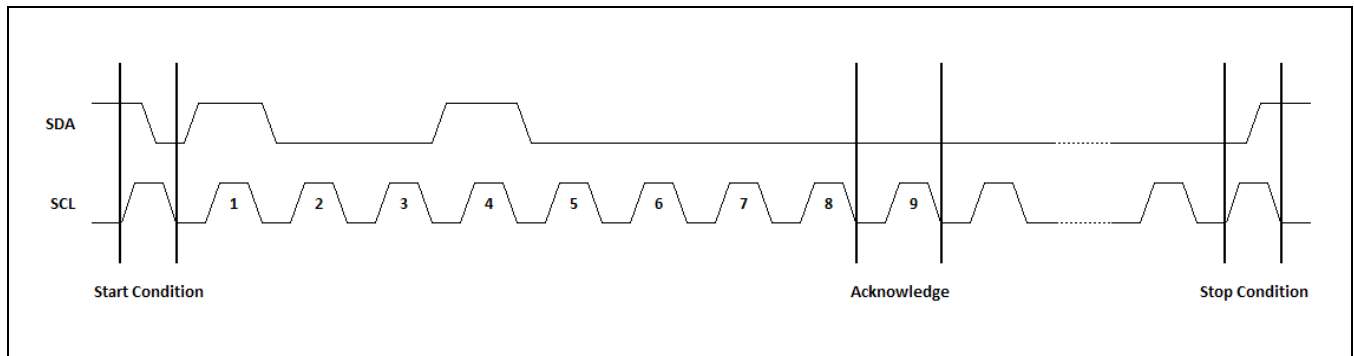
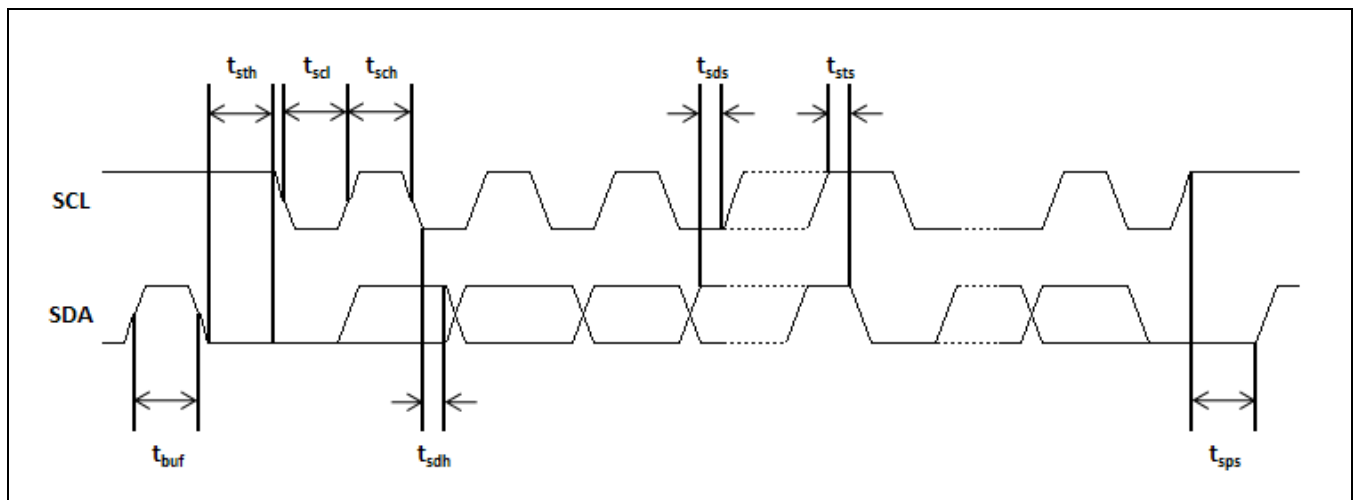

Figure 3.3 I²C™ Data Transmission Timing



3.3. Status and Configuration Registers

Table 3.1 Register Description (Device Address = 48_{HEX})

Register	Address (HEX)	Name	Default (HEX)	Description
0	00	STATUS	00	Status bit register.
1	N/A	N/A	N/A	Register not implemented.
2	02	CONFIG1 ¹⁾	EEPROM	Configuration register.
3	N/A	N/A	N/A	Register not implemented.
4	04	CONFIG3 ¹⁾	EEPROM	Configuration register.
5-16	N/A	N/A	N/A	Registers not implemented.
17	11	CONFIG_ENABLE	00	Enable configuration register access.
18	12	EEPROM_CTRL ¹⁾	00	EEPROM control register.

¹⁾ CONFIGx and EEPROM_CTRL registers are only accessible when CONFIG_ENABLE register is written with the EN_CFG bit set to 1 (see Table 3.5).

Table 3.2 STATUS Register—Address 00_{HEX}

Note: All of the STATUS register bits are READ-only.

Data Bit	D7	D6	D5	D4	D3	D2	D1	D0
Field Name	VOUT_OV	Not Used	Not Used	Not Used	TSD	Not Used	VIN_UV	Not Used
Field Name	Bit Definition					Indication ¹⁾		
VOUT_OV	VOUT Over-Voltage					Fault		
TSD	Thermal Shutdown					Warning		
VIN_UV	VIN Under-Voltage					Warning		

¹⁾ Faults cause the NFLT pin to be pulled low. Warnings do not cause the NFLT pin to be pulled low. All status bits are cleared after register read access. NFLT pin will go high impedance (open drain output) after the status register has been read and all status bits have been reset.

Table 3.3 Configuration Register CONFIG1—Address 02_{HEX}

Note: All of the CONFIG1 register bits are READ/WRITE.

Data Bit	D7	D6	D5	D4	D3	D2	D1	D0
Field Name	Not Used		V_TERM [2:0]			Not Used		
Field Name		Bit Definition						
V_TERM [2:0]		Voltage Termination (V_{OUT}) Configuration: 000 – 2.48V 001 – 2.54V 010 – 2.60V 011 – 2.66V 100 – 2.68V 101 – 2.72V 110 – 2.74V 111 – (Factory use only)						

Table 3.4 Configuration Register CONFIG3—Address 04_{HEX}

Note: All of the CONFIG3 register bits are READ/WRITE.

Data Bit	D7	D6	D5	D4	D3	D2	D1	D0
Field Name	MAX_CHRG_CURR [3:0]				Not Used			
Field Name		Bit Definition						
MAX_CHRG_CURR [3:0]		Maximum Charge Current (I_{OUT}) Configuration: 0000 – 50mA 0001 – 100mA 0010 – 200mA 0011 – 300mA 0100 – 400mA 0101 – 500mA 0110 – 600mA 0111 – 700mA 1000 – 800mA 1001 – 900mA 1010 – 1000mA 1011 – 1100mA 1100 – 1200mA 1101 – 1300mA 1110 – 1400mA 1111 – 1500mA						

Table 3.5 Enable Configuration Register CONFIG_ENABLE—Address 11_{HEX}

Note: The reset value for all of the CONFIG_ENABLE register bits is 0.

Data Bit	D7	D6	D5	D4	D3	D2	D1	D0
Field Name	Not Used	Not Used	Not Used	Not Used	Not Used	Not Used	Not Used	EN_CFG
READ/WRITE	R	R	R	R	R	R	R	R/W
Field Name		Bit Definition						
EN_CFG		Enable Access Control Bit for Configuration Registers 02 and 04: 0 – Disable access 1 – Enable access						

Table 3.6 EEPROM Control Register EEPROM_CTRL—Address 12_{HEX}

Note: The reset value for all of the EEPROM_CTRL register bits is 0.

Data Bit	D7	D6	D5	D4	D3	D2	D1	D0
Field Name	Not Used	Not Used	Not Used	Not Used	Not Used	Not Used	Not Used	EE_PROG
READ/WRITE	R	R	R	R	R	R	R	R/W
Field Name		Bit Definition						
EE_PROG ¹⁾		EEPROM Program Control Bit for Configuration Registers 02 and 04: 0 – Disable EEPROM programming 1 – Enable EEPROM programming with data from configuration registers 2 and 4						
1) EE_PROG Note: Inputs VIN and EN must be present for 200ms.								

4 Application Circuits

4.1. Typical Application Circuits

Figure 4.1 Application Circuit

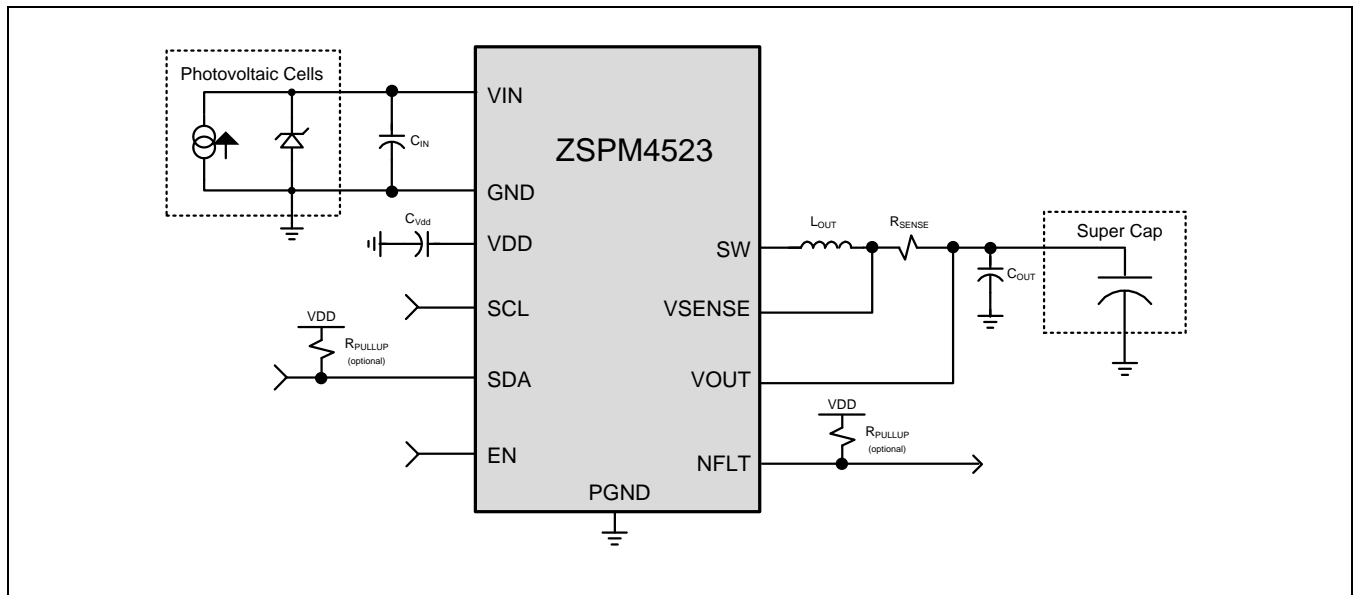

4.2. Selection of External Components

Note that the internal compensation is optimized for a $4.7\mu\text{F}$ output capacitor (C_{OUT}) and a $4.7\mu\text{H}$ output inductor (L_{OUT}). Table 1.3 provides recommended ranges for most of the following components.

4.2.1. C_{OUT} Output Capacitor

To keep the output ripple low, a low ESR (less than $35\text{m}\Omega$) ceramic capacitor is recommended for the $4.7\mu\text{F}$ output filter capacitor. The ESR should not exceed $100\text{m}\Omega$.

4.2.2. L_{OUT} Output Inductor

For best performance, an inductor with a saturation current rating higher than the maximum V_{OUT} load requirement plus the inductor current ripple should be used for the $4.7\mu\text{H}$ output filter inductor.

4.2.3. C_{IN} Bypass Capacitor for Input from Photovoltaic Source

For best performance, a low ESR ceramic capacitor should be used for the $10\mu\text{F}$ input supply bypass capacitor. If it is not a low ESR ceramic capacitor, a $0.1\mu\text{F}$ ceramic capacitor should be added in parallel to C_{IN} .

4.2.4. C_{VDD} Bypass Capacitor for VDD Internal Reference Voltage Output

For best performance, a low ESR ceramic capacitor should be used for the 100nF bypass capacitor from the VDD pin to ground.

4.2.5. R_{SENSE} Output Sensing Resistor

The typical value for the output sensing resistor is 50m Ω .

4.2.6. Pull-up Resistors

For proper function of the I²C™ interface, the SDA pin must be connected to a positive supply (e.g., the VDD pin) through an external pull-up resistor.

For proper function of the fault-warning signal on the NFLT pin, it must be connected to a positive supply (VDD) through an external pull-up resistor.

5 Pin Configuration and Package

5.1. ZSPM4523 Package Dimensions

Figure 5.1 PQFN-16 Package Dimensions

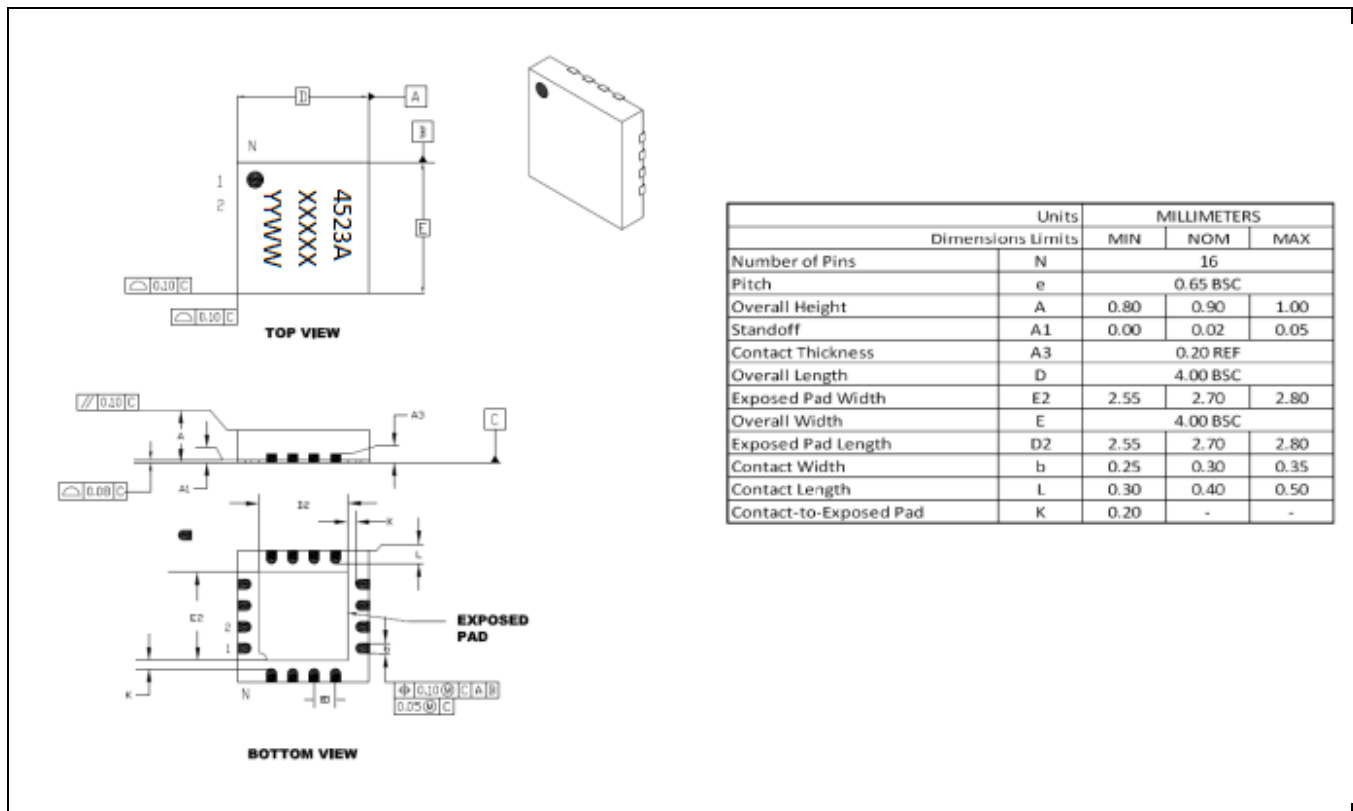

5.2. Pin Assignments

Figure 5.2 ZSPM4523 Pin Assignments for 16-Pin 4mm x4mm PQFN

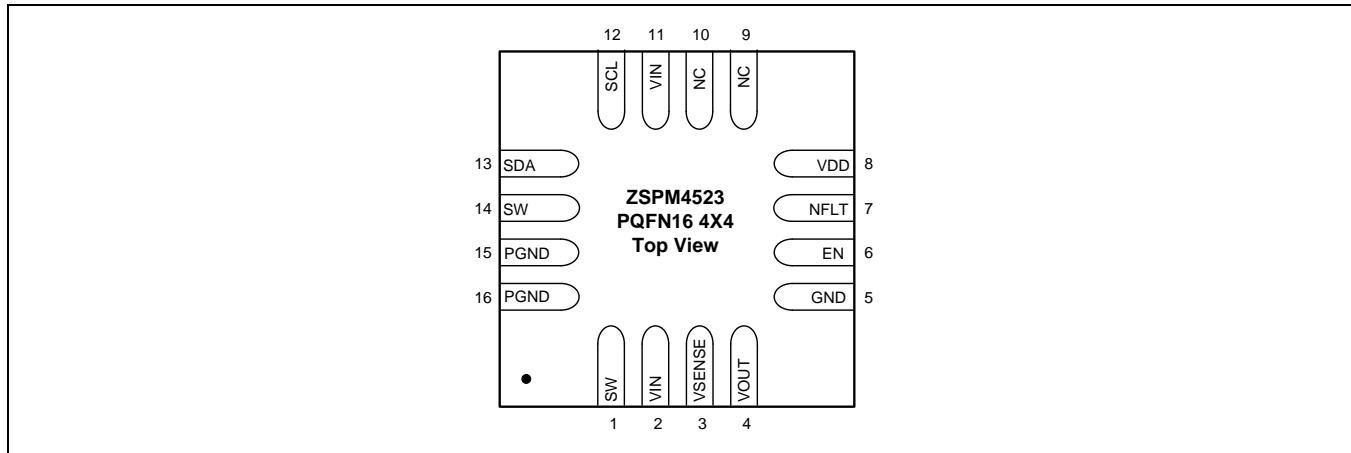

5.3. Pin Description

Table 5.1 ZSPM4523 Pin Description

Pin #	Name	Function	Description
1	SW	Switching Voltage Node	Connected to 4.7 μ H (typical) inductor L _{OUT} . Also connect to additional SW pin 14.
2	VIN	Photovoltaic Input Voltage	Input voltage for the photovoltaic cell. Also connect to C _{IN} . Also connect to additional VIN pin 11.
3	VSENSE	Current Sense Positive Input	Positive input for the MPPT current loop. Connect to the R _{SENSE} resistor to VOUT and the L _{OUT} inductor to SW.
4	VOUT	Super Cap Voltage	Regulator feedback input. Connect to the R _{SENSE} resistor to VSENSE and the C _{OUT} capacitor to ground across the load.
5	GND	GND	Primary ground for the majority of the device except the low-side power FET.
6	EN	Enable Input	When EN is high (≥ 2.2 V), the device is enabled. Ground the pin to disable the device. Includes internal pull-up.
7	NFLT	Inverted Fault	Open-drain output.
8	VDD	Internal 3.3V Supply Output	Connect to a 100nF capacitor to GND.
9	NC	Unused	Ground this pin for applications.
10	NC	Unused	Ground this pin for applications.
11	VIN	Photovoltaic Input Voltage	Additional VIN pin for input voltage from the photovoltaic cell; connect to VIN pin 2.
12	SCL	Clock Input	I ² C™ clock input.

Pin #	Name	Function	Description
13	SDA	Data Input/Output	I ² C™ data (open-drain output).
14	SW	Switching Voltage Node	Additional SW pin; connect to SW pin 1.
15	PGND	Power GND	GND supply for internal low-side FET/integrated diode. Also connect to additional PGND pin 16.
16	PGND	Power GND	GND supply for internal low-side FET/integrated diode. Also connect to additional PGND pin 15.

5.4. Package Markings

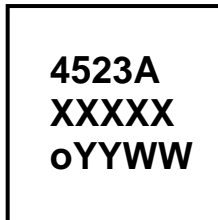

XXXXX:	Lot Number (last five digits)
O:	Pin 1 mark
YY:	Year
WW:	Work Week

6 Layout Recommendations

To maximize the efficiency of this package for application on a single layer or multi-layer PCB, certain guidelines must be followed when laying out this part on the PCB.

6.1. Multi-Layer PCB Layout

The following are guidelines for mounting the exposed pad ZSPM4523 on a multi-Layer PCB with ground a plane. In a multi-layer board application, the thermal vias are the primary method of heat transfer from the package thermal pad to the internal ground plane. The efficiency of this method depends on several factors, including die area, number of thermal vias, and thickness of copper, etc.

Figure 6.1 Package and PCB Land Configuration for Multi-Layer PCB

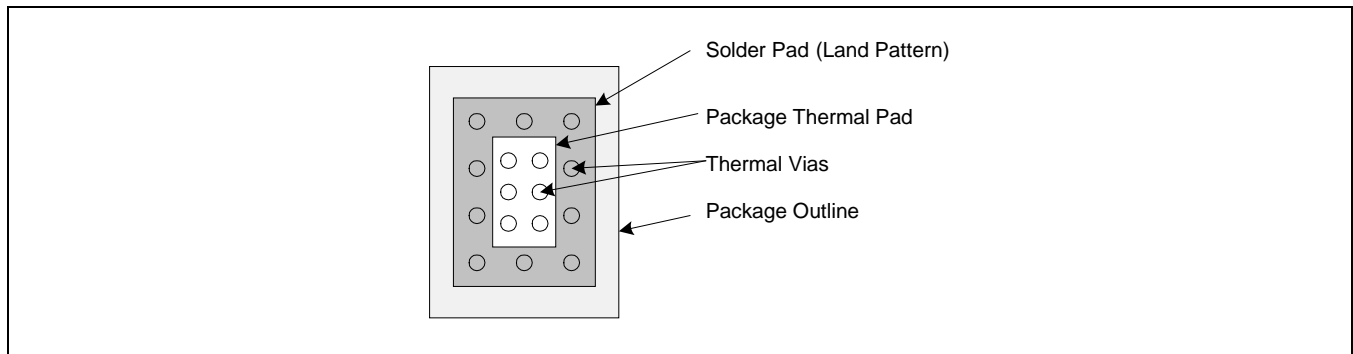

Figure 6.2 JEDEC Standard FR4 Multi-Layer Board – Cross-Sectional View

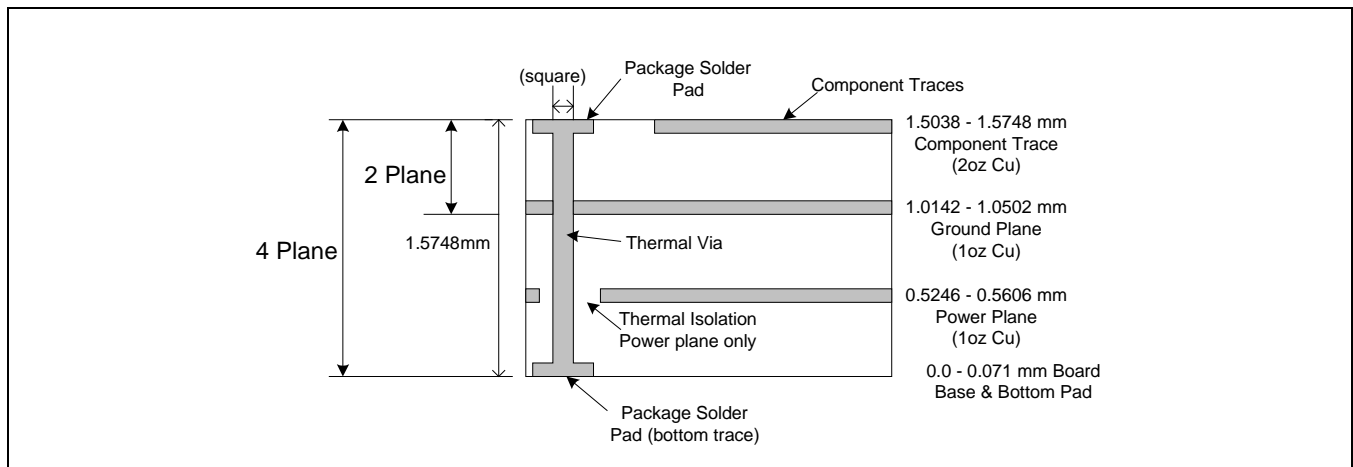
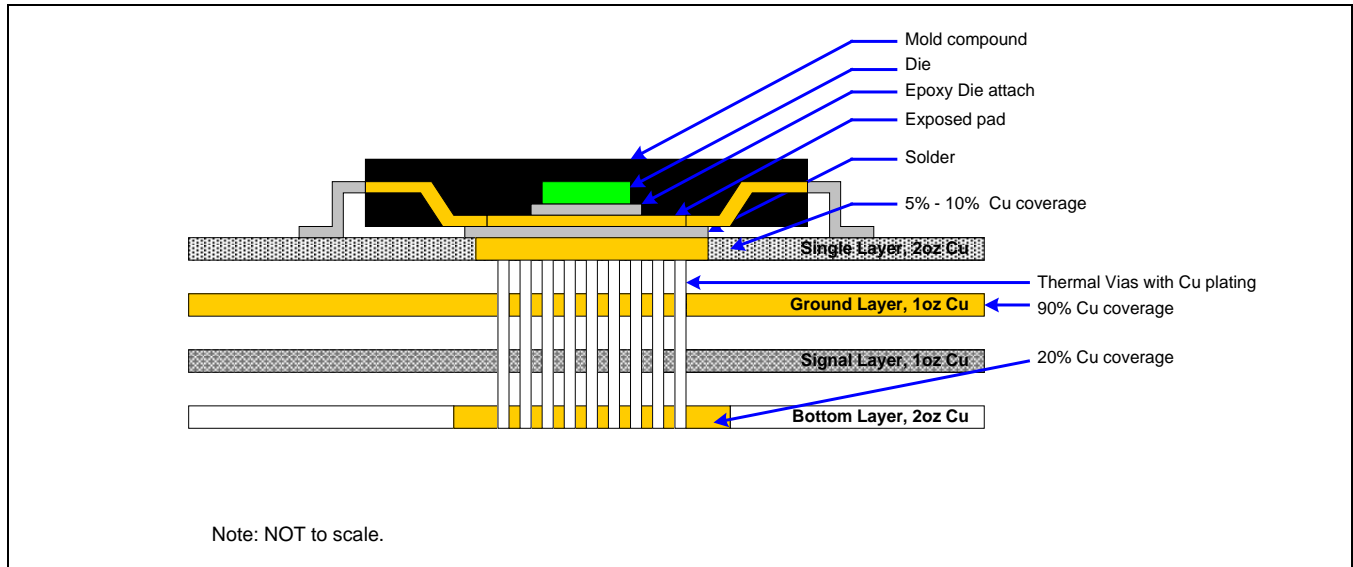

Figure 6.3 is a representation of how the heat can be conducted away from the die using an exposed pad package. Each application will have different requirements and limitations, and therefore the user should use sufficient copper to dissipate the power in the system. The output current rating for the linear regulators might need to be de-rated for higher ambient temperatures. The de-rated value will depend on calculated worst case power dissipation and the thermal management implementation in the application.

Figure 6.3 Conducting Heat Away from the Die using an Exposed Pad Package



6.2. Single-Layer PCB Layout

Layout recommendations for a single-layer PCB: Utilize as much copper area for power management as possible. In a single-layer board application, the thermal pad is attached to a heat spreader (copper areas) by using a low thermal impedance attachment method (solder paste or thermal conductive epoxy).

In both of the methods mentioned above, it is advisable to use as much copper trace as possible to dissipate the heat.

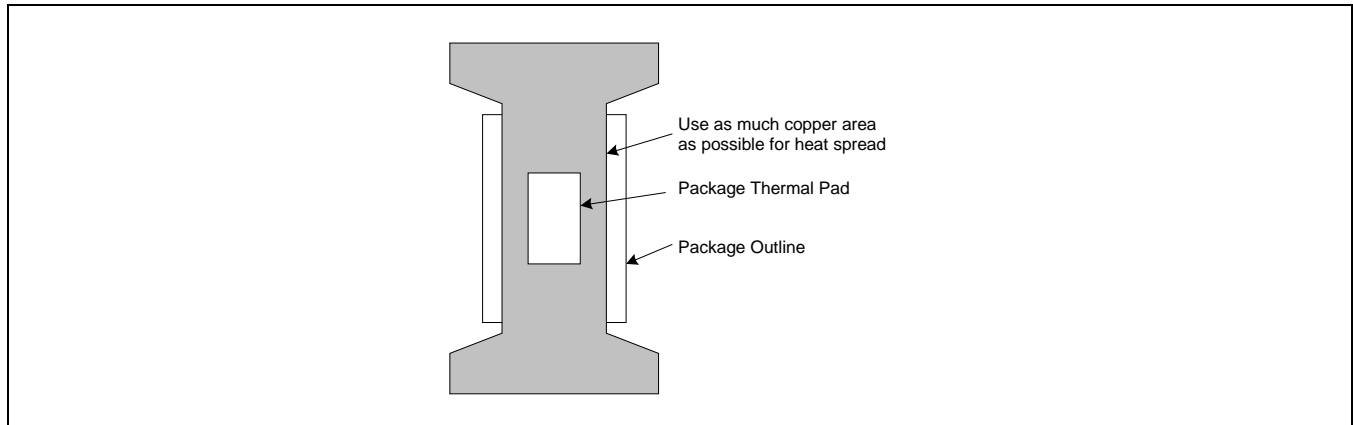
Figure 6.4 Application Using a Single-Layer PCB

Important: If the attachment method is NOT implemented correctly, the functionality of the product is NOT guaranteed. Power dissipation capability will be adversely affected if the device is incorrectly mounted onto the circuit board.

7 Ordering Information

Ordering Code	Description	Package
ZSPM4523AA1W	ZSPM4523 High-Efficiency Regulator for Super Capacitor Systems	16-pin PQFN / 7" Reel (1000 parts)
ZSPM4523AA1R	ZSPM4523 High-Efficiency Regulator for Super Capacitor Systems	16-pin PQFN / 13" Reel (3300 parts)
ZSPM4523KIT	ZSPM4523 Evaluation Kit	

8 Related Documents

Document
<i>ZSPM4523 Feature Sheet</i>
<i>ZSPM4523 Evaluation Kit Description</i>
<i>ZSPM4523 Application Note – Solar Powered Battery Management and Charging Solutions</i>

Visit IDT's website www.IDT.com or contact your nearest sales office for the latest version of these documents.

9 Document Revision History

Revision	Date	Description
1.00	February 14, 2013	First release
1.01	October 5, 2014	Update for contacts and imagery for cover and headers.
	January 29, 2016	Changed to IDT branding.



Corporate Headquarters
 6024 Silver Creek Valley Road
 San Jose, CA 95138
www.IDT.com

Sales
 1-800-345-7015 or 408-284-8200
 Fax: 408-284-2775
www.IDT.com/go/sales

Tech Support
www.IDT.com/go/support

DISCLAIMER Integrated Device Technology, Inc. (IDT) reserves the right to modify the products and/or specifications described herein at any time, without notice, at IDT's sole discretion. Performance specifications and operating parameters of the described products are determined in an independent state and are not guaranteed to perform the same way when installed in customer products. The information contained herein is provided without representation or warranty of any kind, whether express or implied, including, but not limited to, the suitability of IDT's products for any particular purpose, an implied warranty of merchantability, or non-infringement of the intellectual property rights of others. This document is presented only as a guide and does not convey any license under intellectual property rights of IDT or any third parties.

IDT's products are not intended for use in applications involving extreme environmental conditions or in life support systems or similar devices where the failure or malfunction of an IDT product can be reasonably expected to significantly affect the health or safety of users. Anyone using an IDT product in such a manner does so at their own risk, absent an express, written agreement by IDT.

Integrated Device Technology, IDT and the IDT logo are trademarks or registered trademarks of IDT and its subsidiaries in the United States and other countries. Other trademarks used herein are the property of IDT or their respective third party owners. For datasheet type definitions and a glossary of common terms, visit www.idt.com/go/glossary. All contents of this document are copyright of Integrated Device Technology, Inc. All rights reserved.