

Datasheet

FS9922-DMM4

Integrated Circuits of 6,000 Counts
Auto-ranging Digital Multimeter with Bar Graph

FORTUNE,
Properties
For Reference Only

Fortune Semiconductor Corporation**富晶電子股份有限公司**23F., No.29-5, Sec. 2, Zhongzheng E. Rd.,
Danshui Town, Taipei County 251, Taiwan

Tel. : 886-2-28094742

Fax : 886-2-28094874

www.ic-fortune.com

This manual contains new product information. **Fortune Semiconductor Corporation** reserves the rights to modify the product specification without further notice. No liability is assumed by **Fortune Semiconductor Corporation** as a result of the use of this product. No rights under any patent accompany the sale of the product.

Contents

1.	GENERAL DESCRIPTION	5
2.	FEATURES	5
3.	MEASURING MODE	6
4.	APPLICATIONS FIELD	6
5.	BLOCK DIAGRAM	6
6.	PIN ASSIGNMENT	7
7.	PIN DESCRIPTION	7
8.	TECHNICAL SPECIFICATION	9
8.1	Max. Rated Value	9
8.2	Electrical Parameters	10
9.	MEASURING MODES SELECT	11
9.1	Coding Table	11
9.2	ADP Input/User-Defined Symbols and Confirmation of Decimal Locations	12
10.	KEYS DEFINITION	13
10.1	RANGE Key	13
10.2	RELA/RS232 Key	13
10.3	HOLD/LIGHT Key	13
10.4	SELECT Key	14
10.5	HZ/DUTY Key	14
10.6	MAX/MIN DATA HOLD Key	14
11.	OTHER FUNCTIONS	14
12.	APPLICATION	15
12.1	FS9922_DMM4 Circuitry	15
12.2	FS9922-DMM4 Circuitry Components List	16
12.3	Power Supply System	16
12.4	Power Supply Circuit	17
12.5	Base Power Source	18
12.6	Trigger Reset Circuit	19
12.7	Oscillation Circuit	19
12.8	Buzzer Driver Circuit	20
12.9	Mode Switch and Function Control Circuit	20
12.10	AC Rectification Circuit	21
12.11	Voltage Measurement	23

12.12	AC/DC mV Voltage Measurement.....	24
12.13	Current Measurement.....	25
12.14	Clamp Meter Circuit.....	25
12.15	Resistance Measurement.....	26
12.16	Diode Test.....	27
12.17	Continuity Test.....	27
12.18	Transistor hFE Test.....	28
12.19	Capacitance Measurement.....	28
12.20	Frequency Measurement.....	29
12.21	High Frequency Measurement.....	29
12.22	RPM Measurement.....	29
12.23	Temperature Measurement.....	30
13.	RS232 TRANSMISSION SPECIFICATION.....	30
14.	LCD.....	33
14.1	Plane Structure of LCD.....	33
14.2	Table of True Valid Value of LCD.....	33
14.3	Description of Symbols of LCD.....	34
15.	PACKAGE OUTLINE & PAD ASSIGNMENT.....	34
15.1	Package Outline.....	34
15.2	Pad Assignment.....	35
15.3	Pad Coordination.....	36
16.	ORDERING INFORMATION.....	36
17.	REVISION HISTORY.....	37

1. General Description

FS9922-DMM4 is a high performance, low power consumption and 3 6/7 digits (6000 Counts) dual Analog to Digital Converter with a built-in microprocessor. It includes a 8 bits microprocessor, low noise and the OPAMP of high stability, AC rectifier OPAMP, voltage doubling and regulated voltage, highly regulated bandgap, auto measurement switch and function control circuit, buzzer driver circuit, clock oscillation circuit, backlight display control circuit, LCD driver circuit and so on.

Built-in dual Analog to Digital Converter, one is a high accuracy ADC for main measurement; the other is a high speed ADC whose measurement result shows by a 61 segment analog section bar that can respond fast, the analog indication owns the property of immediate response and can provide the fast measurement and monitoring of instant signals.

With the microprocessor, FS9922-DMM4 can do the logic function control via the I/O ports. By selecting the codes of MEA1~MEA5 pins can realize various functions during measurement.

By triggering the keys of the settings of SELECT, RANGE, REL/RS232, HZ/DUTY, HOLD/LIGHT, MAX/MIN keys, you can realize the functions of function switch, measurement mode select, relative value measurement, frequency/duty cycle measurement, reading hold, MAX/MIN value hold, backlight display, RS232 output and so on.

With the auto power off function, when there is no action on the mode switch or keys of the meter within 15 minutes, the system will enter into the sleep mode automatically to save the power. This function can also be cancelled during use.

FS9922-DMM4 has LCD driver circuits, which is designed for driving LCD.

FS9922-DMM4 is made by the large integrated circuit technology, and therefore greatly rises up the reliability of the product. It makes the design simple, the volume small, low power consumption by using 3V power source, and convenient to use the power supply of battery, especially suitable for the application on the palm mode meter.

FS9922-DMM4 is a microprocessor-embedded and multifunctional measuring dual ADC; fewer external components added can form a high accuracy, multifunctional and low cost measuring meter.

2. Features

- Max. Display: 6000 Counts (Frequency 9999), Bar graph 61 segments.
- Converter Rate: 3 times/sec; Bar graph: 30 times/sec.
- Measuring Mode: Auto/Manual measurement.
- Pole Indication: Auto.
- Operation Voltage: 2.4V~3.6V.
- Operation Current: $\leq 2\text{mA}$
- Low Power Indication: about 2.4V.
- Buzzer Frequency: about 2.7kHz.
- AC Rectifying: Embedded OPAMP.
- Current Resistance: μA is 50Ω ; mA is 0.5Ω ; A is 0.005Ω .
- Function Keys: SELECT, RANGE, REL/RS232, HZ/DUTY, HOLD/LIGHT, MAX/MIN.
- Data Output: RS232 (2400bps).
- Auto Power-off: 15min. (can be cancelled)
- Unit Symbol and Backlight Display.

3. Measuring Mode

- DCV: 60.00mV, 600.0mV, 6.000V, 60.00V, 600.0V, 6000V.
- ACV: 60.00mV, 600.0mV, 6.000V, 60.00V, 600.0V, 6000V.
- DCA: 600.0μA/6000μA, 60.00mA/600.0mA, 6.000A/60.00A, 600.0A, 6000A.
- ACA: 600.0μA/6000μA, 60.00mA/600.0mA, 6.000A/60.00A, 600.0A, 6000A.
- OHM: 600.0Ω, 6.000kΩ, 60.00kΩ, 600.0kΩ, 6.000MΩ, 60.00MΩ.
- Capacitance: 40.00nF, 400.0nF, 4.000μF, 40.00μF, 400.0μF, 4000μF(30sec.).
- Frequency: 9.999Hz, 99.99Hz, 999.9Hz, 9.999kHz, 99.99kHz, 999.9kHz, 9.999MHz.
- RPM: 9.999kRPM, 99.99kRPM.
- Duty Cycle: 0.1%~99.9%.
- Temperature: -273.0°C ~+400.0°C (-459.4°F , +752.0°F) / -273°C ~+ 4000°C (-459°F , +7232°F).
- Diode Test: 0V~2.0V.
- Continuity Test: Test on 600.0Ωmode; sound when lower than 30Ω.
- Transistor hFE: 0~1000(hFE).

4. Applications Field

- Auto Measurement Palm Mode Digital Multifunctional Meter.
- Auto Measurement Card Digital Multifunctional Meter.
- Auto-Measurement Pen Digital Multifunctional Meter.
- Auto-Measurement Clamp Meter.
- Number Panel Meter.

5. Block Diagram

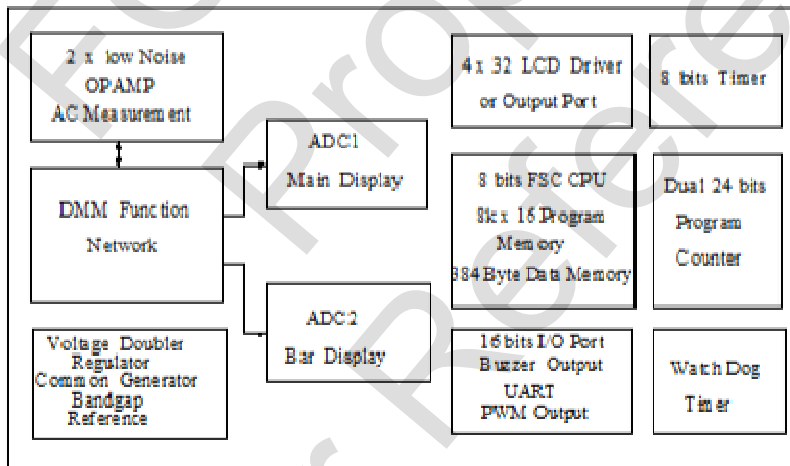

Diagram 1 FS9922-DMM4 Block Diagram

6. Pin Assignment



Diagram 2: Pin Assignment

7. Pin Description

No.	Name	In/Out	Description	No.	Name	In/Out	Description
1	OP2N	I	OPAMP 1 Negative Input	68	VDDA	I/O	Regulated Power Output
2	OP2P	I	OPAMP 1 Positive Input	69	VGG	I/O	Charge Pump Voltage Output
3	REFO	O	Band gap Referenced Output	70	CA	I/O	Charge Pump Capacitor Positive Connection
4	REF1	I	ADC Referenced Voltage Input	71	CB	I/O	Charge Pump Capacitor Negative Connection
5	FTC2	I/O	ADC2 Pre-Filter Capacitor Connection	72	VDD	I	Positive Power Supply
6	FTB2	I/O	ADC2 Pre-Filter Capacitor Connection	73	Buzzer	I/O	Buzzer Driver Output
7	FTC1	I/O	ADC1 Pre-Filter Capacitor Connection	74	LBOU T	I/O	Backlight Driver Output
8	FTB1	I/O	ADC1 Pre-Filter Capacitor Connection	75	MAX/MIN	I/O	Max/Min Data Hold
9	ADP2	I	Low Power Test Input (shall be connected to VDD when power supply is by 3V.)	76	HZ/DUTY	I/O	Frequency/Duty Cycle Select
10	ADP	I	Extra ADC Positive Input	77	REL/RS232	I/O	Relative Value Measurement / RS232 Control
11	AD1P	I	ADC Positive input of AC voltage measurement	78	HOLD/LIGHT	I/O	Reading Hold / Backlight Output Control
12	AD1N	I	ADC Negative input of AC measurement	79	RANGE	I/O	Auto/Manual Mode Switch Select

13	SGND	I	ADC Negative input of analog ground	80	SELECT	I/O	Measurement Function Select
14	SA	I	ADC Input of Current measurement /mV High impedance input /Input of Temperature & hFE Measurement	81~83	NC	O	No use
15	DT	I	Diode measurement Voltage Divide Resistance connection point	84	RST	I	CPU Reset
16	SMV	I	ADC Positive Input of Resistance Measurement /Diode measurement Voltage Divide point	85	PWDT	I	No use
17	CRES1	I	Connection point of filter capacitor in resistance measurement	86	XOUT1	O	Oscillator Connection
18	RL	I	Negative input of referenced voltage in resistance measurement	87	XIN1	I	Oscillator Connection point
19	RCAP1	O	Capacitor Measurement Connection Point	88	MEA4	I/O	Measurement Function Select
20	RCAP2	O	Capacitor Measurement Connection Point	89	MEA3	I/O	Measurement Function Select
21	ONEK	I	1.001kΩResistance connection point	90	MEA2	I/O	Measurement Function Select
22	TENK	I	10.01kΩ Resistance connection point	91	MEA1	I/O	Measurement Function Select
23	HUNK	I	101.01kΩResistance connection point	92	TXD	I/O	RS232 Output
24	ONEM	I	1.111MΩResistance connection point Voltage	93	MEA5	I/O	Measurement Function Select
25	TENM	I	10.000MΩResistance connection point	94	TXEN	I/O	Operation→L, Sleep→H
26~28	NC		No Connection	95	INT	I/O	External Interrupt Input
29	VB	I	Analog Circuit Bias Current Input	96	VSS	I	Negative Power Supply
30	AGND	I/O	Analog Signal Ground	97	NC		No Connection
31~62	SEG32 ~ SEG1	O	LCD Segment 32~1	98	OP1N	I	Buffer OPAMP Reverse Input
63~66	COM4 ~ COM1	O	LCD Common Driver Output 4 1	100	OP2O	O	Rectifying OPAMP Output
67	RLCD	I/O	LCD Bias Voltage Input				
Note : I—Input ; O—Output ; I/O—Input / Output.							

8. Technical Specification

Max. Rated Value

Parameter	Symbol	Rated Value	Unit
Power Supply Voltage	VDD~VSS	3.6	V
I/O Voltage Level	Vid	-0.3 ~ VDD +0.3	V
Ambient Temperature	Ta	0 ~ + 70	°C
Storage Temperature	Tstg	-40 ~ + 125	°C
Welding Temperature	Temp	280	°C
Welding Time	Time	5	s

Electrical Parameters

Symbol	Parameter	Test Condition	Min.	Typical	Max.	Unit
VDD	Recommended Operation Power Voltage		2.4		3.6	V
IDD	Operation Current	In DCV Mode		1.5	3	mA
IPO	Sleep Current	In Auto Power-off Status			10	μA
VIH	Digital High Voltage Level		VDD-0.5			V
VIL	Digital Low Voltage Level				0.5	V
AGND	Analog Ground Voltage		VDDA/2 -3%	VDDA/2	VDDA/2 +3%	V
VDDA	Analog Power Supply		3.4	3.9	4.4	V
VBAND	Built in Bandgap Voltage	Voltage Relative to AGND	1.1	1.25	1.4	V
	Coefficient of curve of Bandgap Voltage along with power voltage	VDD=2.4~3.6V			2	mV/V
REFI	Recommended referenced Voltage	Voltage Relative to AGND		0.63		V
VBATT	Low Voltage Detector	Use DC 3V	2.25	2.4	2.55	V
FLCD	LCD Frequency			32		Hz
VLCD	LCD PK-PK Driver Voltage		2.8	3	3.2	V
FBEEP	Buzzer Frequency			2.7		kHz
FRS232	RS232 Baud Rate			2400		bps
IRSOUT	RS232 Transmission High Voltage Level Current	VOH=2V	2			mA
	"0" Input Reading	DC ADP×1 Input=0V	-1	0	1	digits
	Linearity (Max. Deviation From Best Straight Line Fit)	DC ADP×1 Full Scale±400mV	-1	0	1	Bit
	AC Measurement Bandwidth Error	AC ADP×1 Input 400mVrms 20Hz~1kHz			0.2	%
RCC	Continuity Check Value		10		60	Ω
	ADC Measurement O.L Display Count			6040		counts
	Auto range Up Count			6040		counts
	Auto range Down Count			560		counts
VFREA	Frequency Count Voltage (Hz/Duty Control)	VIL (relative to AGND)	-60			mV
		VIH (relative to AGND)			60	mV
FMAXA	Max. Frequency Input (Hz/Duty Control)	Vpp=±100mV Square Wave Input	500			kHz
*1	Duty Cycle Measurement Deviation (Hz/Duty Control)	Vpp=±100mV Square Wave Input			1	μs
VFRED	Frequency Count Input Voltage (MEAS=10100)	VIL (relative to AGND)	-600			mV
		VIH (relative to AGND)			600	mV
FMAX	(MEAS=10100) Input Frequency of Frequency Count	Vpp=±600mV Square Wave Input	5			MHz
*1	(MEAS=10100)Duty Cycle Measurement Deviation	Vpp=±600mV Square Wave Input			100	ns
	Accuracy of Capacitance Measurement in Relative Value Measurement Status (by 600.0nF Mode standard adjustment)	60.00 nF Mode			2%+10	digits
		600.0 nF Mode			0.5%+3	digits
		6.000 μF Mode			1%+2	digits
		60.00 μF Mode			1.5%+2	digits

*1 During Duty Cycle measurement, when a square wave is input, the difference comes mainly from the analyzable impulse width difference of the competitor. If the input is a 100kHz square wave, which can be divided into 1000 counts, each count is 10 ns. Therefore, the max. difference is (100ns/10 ns)=10Counts, 50.0%±1.0% can be measured from 50.0% of output signal. The signal larger than 99% or less than 1% might not be able to be measured.

9. Measuring Modes Select

Coding Table

(MEA1~MEA5: no connection is "1"; connect to INT is "0")

MEA5	MEA4	MEA3	MEA2	MEA1	Mode	SELECT	REL	HOLD	Hz Duty	RANGE	MAX MIN
1	0	1	1	0	AC V (6.000V~6000V)		•	•	•	•	•
1	1	0	1	0	DC V (600.0mV~6000V)		•	•		•	•
1	1	1	0	0	DC/AC mV (60.00mV/600.0mV)	DC/AC	•	•	•	•	•
1	0	0	0	1	DC / AC V(600.0mV~6000V)	DC/AC	•	•	•	•	•
1	0	0	1	0	Ohm / (Hi) Ohm	Ω/(Hi)Ω	•	•		•	•
1	0	1	0	0	Hz/Duty			•	•		
1	1	0	0	0	Diode/Beeper	D/B					
1	0	0	1	1	Cap.		•	•			
1	0	1	0	1	Ohm/ Diode/Beeper/cap.	Ω/D/B/C	•	•		•	•
1	1	0	0	1	RPM / Hi Hz	RPM / Hz		•			
1	0	1	1	1	°C/°F (-273.0°C~+400.0°C/-273°C~+ 4000°C)	°C/°F	•	•		•	•
1	0	0	0	0	HFE						
1	1	0	1	1	DC/AC μA(600.0μA /6000μA)	DC/AC	•	•	•	•	•
1	1	1	0	1	DC/AC mA (60.00mA/600.0mA)	DC/AC	•	•	•	•	•
1	1	1	1	0	DC/AC A (6.000A/60.00A)	DC/AC	•	•	•	•	•
0	0	1	1	0	AC V (6.000V~6000V)		•	•	•	•	•
0	1	0	1	0	DC V (600.0mV~6000V)		•	•		•	•
0	1	1	0	0	Ohm/Beeper	Ω/B	•	•		•	•
0	0	0	0	1	AC/DCmV (60.00mV/600.0mV)	AC/DC	•	•	•	•	•
0	0	0	1	0	AC/DC V (600.0mV~6000V)	AC/DC	•	•	•	•	•
0	0	1	0	0	AC/DC A(6.000A)	AC/DC	•	•	•		•
0	1	0	0	0	AC/DC A(60.00A)	AC/DC	•	•	•		•
0	0	0	1	1	AC/DC A(600.0A)	AC/DC	•	•	•		•
0	0	1	0	1	AC/DC A(6000A)	AC/DC	•	•	•		•
0	1	0	0	1	ADP (6000)		•	•			•
0	0	1	1	1	ADP (600.0)		•	•			•
0	1	0	1	1	ADP (60.00)		•	•			•
0	1	1	0	1	ADP (6.000)		•	•			•
0	1	1	1	0	°F/°C (-273.0°C~+400.0°C/-273°C~+ 4000°C)	°F/°C	•	•		•	•
1	1	1	1	1	°C/°F	°C/°F	•	•			•
0	0	0	0	0	AC/DC A (6.000A/60.00A)	AC/DC	•	•	•	•	•
0	1	1	1	1	Ohm/Beeper/Diode	Ω/B/D	•	•		•	•

Note: "•" means the function key in the column is in operation

ADP Input/User-Defined Symbols and Confirmation of Decimal Locations

(MEA1~MEA5: no connection is "1"; connect to INT is "0")

ME A5	ME A4	ME A3	ME A2	ME A1	Input Voltage Range	Input channel	Decimal Location	Symbol Location	Symbol
0	1	1	0	1	±600mV	SA	6.000	COM4, SEG22	Defined by users
0	1	0	1	1			60.00	COM4, SEG23	
0	0	1	1	1			600.0	COM4, SEG24	
0	1	0	0	1			6000	COM4, SEG25	

Note: Character locations of "Hi" of High Frequency and High Resistance Measurement are in COM4, SEG31.

10. Keys Definition

RANGE Key

Range key is the Auto/Manual measurement key that acts with trigger. Auto measurement is pre-set as power-on, and switches to Manual measurement when the key is pressed one time. In Manual measurement mode, mode will move upward upon each press to the highest mode, then return to the lowest mode as a loop. If press the key over 2 seconds, the system will switch back to Auto measurement status.

REL Δ /RS232 Key

A. REL Δ Measurement

- 1) REL Δ /RS232 key is the relative value measurement/RS232 communication transmission key that acts with trigger. Press this key will enter into the relative value measurement mode. The system will save the display value in the memory as the reference value. When doing the measurement later, the display value will be the difference value that the entry value deducts the reference value.
- 2) REL Δ (current reading) = entry value – reference value
- 3) The relative value measurement can be carried out under the certain measurement mode, i.e., the function is available only under the Manual Measurement Mode.
- 4) Press REL Δ key will enter into the Manual Measurement Mode automatically.
- 5) In REL Δ measurement status, press the key again, the REL Δ function will be relocked.
- 6) Press the key in HOLD status, HOLD function will be cancelled. The system will save the display value in the memory as the reference value. When doing the measurement later, the display value is the difference that the entry value deducts the reference value.
- 7) Press RANGE, SELECT Key or use Mode Switch will cancel REL Δ measurement mode, and go back to the normal mode (REL Δ will disappear in the LCD).
- 8) OL triggering: Under REL Δ mode, OL shows when input value larger than the allowed value of the measurement mode. Press the key again, the relative measurement function will be cancelled. Disable to enter REL Δ mode when OL shows.
- 9) No analog section bar function under REL Δ mode.

B. RS232 Communication Transmission

- 1) Press REL Δ /RS232 key longer than 2 sec. will enter into RS232 and external set communication status ("RS232" shows in LCD).
- 2) After starting RS232 function, press REL Δ key again longer than 2 sec. RS232 function will be cancelled.
- 3) The auto power off function is cancelled in RS232 status, and the signal of "APO" in LCD disappears.

HOLD/LIGHT Key

HOLD/LIGHT is the reading hold/backlight control key.

A. Reading HOLD

- 1) Press the key, the display value will be locked and kept unchanged, "HOLD" shows in LCD. Press the key again, the locked status will be unlocked, and enter into the normal measurement status.
- 2) HOLD function will be unlocked and go back to the normal status when RANGE, SELECT, REL Key or Mode Switch is pressed or used.

B. BACK LIGHT CONTROL

- 1) The backlight control signal will be started when the HOLD key is pressed longer than 2 seconds; then, press the key again longer than 2 seconds, the backlight control signal will be shut off. If the HOLD Key is not pressed longer than 2 seconds after the backlight source is started, the light source will be shut off automatically in 10 seconds.

SELECT Key

- 1) SELECT Key is a function selection key that acts with trigger. Press the key can choose the needed measurement mode: To choose DC or AC in DC/AC status, to choose °C or °F in temperature measurement mode, to choose Diode or Buzzer in Diode/Buzzer status, to choose Ohm, Cap, Diode or Buzzer in Ohm/Cap/Diode/ Buzzer status.
- 2) Press the key then turn on the power, the Auto Power-off function will be cancelled, the signal "APO" disappears in LCD, and enter into Sleep Status (Power-Off). Press the key then power on will have the Auto Power-Off function.

HZ/DUTY Key

Hz/Duty is the key to select Frequency/Duty Cycle and it acts with trigger. In Frequency Measurement Mode, press the key can select Hz or Duty Measurement Mode; in AC/DC Voltage or AC/DC Current Measurement Mode, press the key can select Voltage/Hz/Duty or Current/Hz/Duty Measurement Mode.

MAX/MIN DATA HOLD Key

- 1) Press the MAX/MIN Key will enter into the MAX Mode, the measured max. value will be held; press the key again will enter into the MIN Mode, the measured min. value will be held; press the key again will repeat the a. m. circuit.
- 2) It will enter into the Manual Measurement Mode after enter into the MAX or Min Mode, RELΔ, HOLD, RANGE, SELECT Key function are not available under this mode.
- 3) The measured MAX or MIN value will be saved automatically when enter into MAX or MIN measurement mode.
- 4) No analog section bar function when enter into MAX or MIN mode, and the Auto Power Off function will be cancelled.
- 5) Press the MAX/MIN Key longer than 2 sec. will exit from the MAX or MIN measurement mode.

11. Other Functions

The indication of function signals, units will show in LCD when each of the functions is used.

The time for Auto Power-Off is set to be 15 minutes:

- 1) If the mode switch or keys of the meter is no action within 15 minutes, the system will power off automatically (sleep mode). In Auto Power-off status, press the function key or enable the function switch, the meter will "Auto Power-On" (Operation Mode).
- 2) The signal "APO" of Auto Power-off will show at the same time after the normal power on. The buzzer will remind 5 times sequentially one minute before it is shut off. It will enter into sleep (Power-off) status after a long sound before it is shut off. Enable the Mode Switch or press any key can restart it under the Auto Power-off mode.

Alarm Condition

- 1) Press the function key, the buzzer will sound "Be..." in short.
- 2) One minute before Auto Power-off the buzzer will sound "BeBeBeBeBe" five times to warn. Before it is shut off, the buzzer will sound a long "Beee" then shut off.
- 3) The buzzer will sound "BeBe..." continuously to warn when the measured DC voltage is higher than 1000V,
- 4) AC voltage is higher than 750V, or the measured DC/ACmV mode is higher than 600.0mV.
- 5) The buzzer will sound long when the short circuit resistance is less than the rated value during a short circuit test.

When the voltage is lower than the rated value (it is 2.4V under DC 3V power supply), the low voltage signal will show on LCD. When the power supply is by DC 9V or other voltage value, it can be external distributed to choose the proper voltage value to show the LV. symbol.

INT Input Terminal: When the meter enters into Auto Power-off status (Sleep Mode), IC will be waked up and enter into operation status if there is a signal input at INT Input Terminal.

High Frequency component and RPM component shall be added external during High Frequency and RPM Measurement. High Frequency component is to reform the frequency of 10MHz~1000MHz and sent to the frequency measurement port via 128 frequency division; RPM component is a device to transform the RPM into electrical impulse, the transmitted impulse can be directly sent to the frequency measurement port.

12. Application

FS9922_DMM4 Circuitry

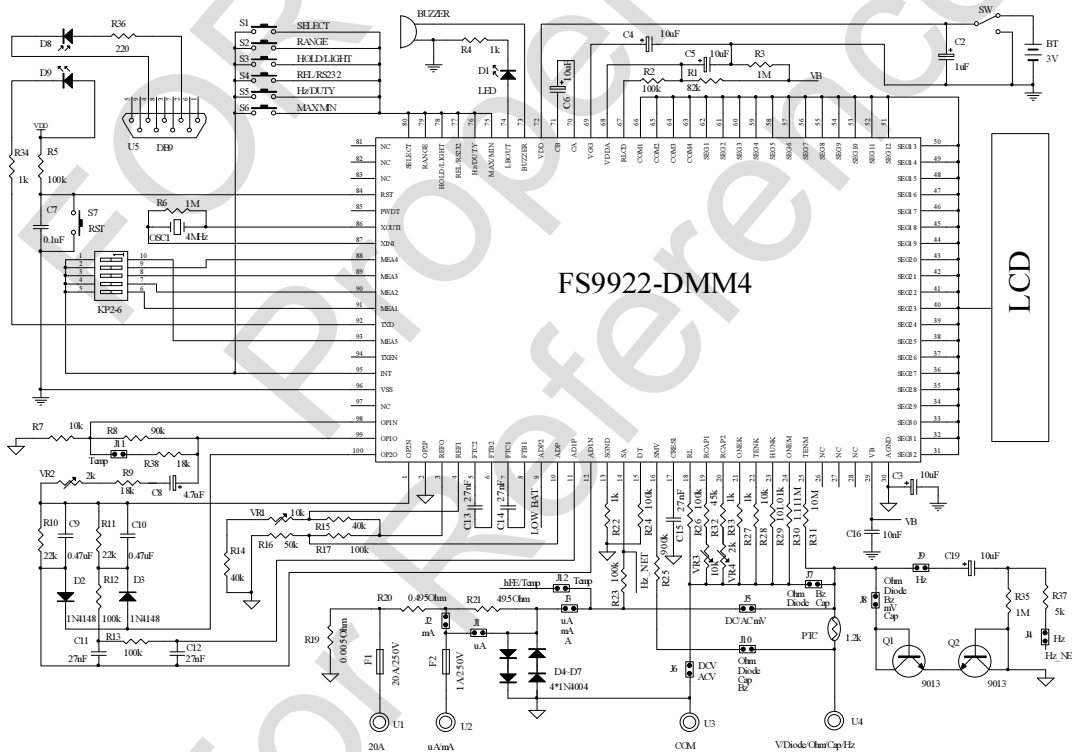

Diagram 3: Application Circuitry

FS9922-DMM4 Circuitry Components List

No.	Spec.	No.	Spec.	No.	Spec.	No.	Spec.
R1	82k	R21	49.5	C8	4.7μF	F1	20A fuse tube
R2 R5 R12 R13 R17 R23 R24 R26	100k	R25	900k	C9 C10	0.47μF	F2	1A fuse tube
R3 R6 R35	1M	R27	1k	C11 C12 C13 C14 C15	27nF	BUZZER	BUZZER
R4 R22 R33 R34	1k	R29	101.01k	C16	10nF	BT	3V Battery
R7 R28	10k	R30	1.111M	D1	LED Diode	VR1 VR3	10kΩ
R8	90k	R31	10M	D2 D3	1N4148	VR2 VR4	2kΩ
R9 R38	18k	R32	45k	D4 D5 D6 D7	1N4004	OSC1	Oscillator
R10 R11	22k	R36	220	D8	Receive Diode	PTC	1.2k Thermistor
R14 R15	40k	R37	5k	D9	Launch Diode	S1~S7	Function Keys
R16	50k	C2	1μF	IC	FS9922-DMM4	KP2-6	Mode Switch
R19	0.005	C3 C4 C5 C6 C19	10μF	Q1 Q2	9013	U5	9 pin connector
R20	0.495	C7	0.1μF	LCD	LCD	U1~U4	Probe

Power Supply System

VB is the bias current input point in IC. The increase of R1 will reduce the current consumption in IC, but the shortage of bias current will affect the input range of AC measurement.

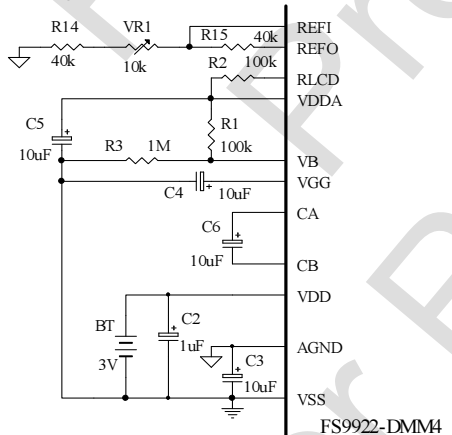

Diagram 4: Power Supply Circuit

AGND is the analog ground connection. Its potential is equal to the middle point of VDDA. The potential of the point is generated in the IC and cannot connect to the middle point of battery. C3 enables AGND stable relative to VSS. C6 is the charge pump, IC let VDD go through C6 to charge/discharge and make VGG to be double of VDD.

VDDA is the output voltage after the regulation of VGG in the IC. It is about 3.9V relative to VSS.
 REFO is the bandgap power source in the IC. It is about 1.2V relative to AGND and has the stability of 100ppm/°C.

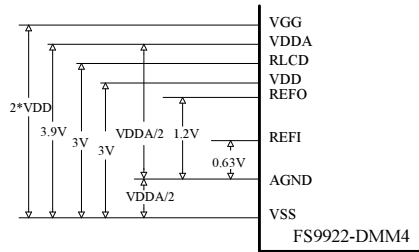

Diagram 5: Relative Voltage at each Point

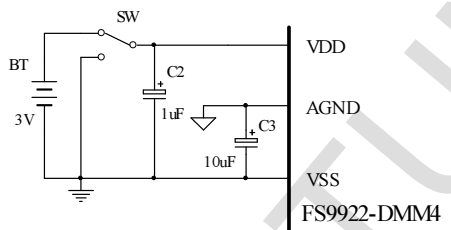

Diagram 6: Power Supply ON/OFF Circuit

Note: In order to avoid “hang up” when FS9922-DMM4 is power-on and off fast, SW should be connected to VSS.

Power Supply Circuit

The different applications of users make different power supply methods. In some measurements, the sensor requires higher voltage such as OPAMP, Hall device and so on. If it is difficult to supply the power by 3V, then you can take some power supply methods as below.

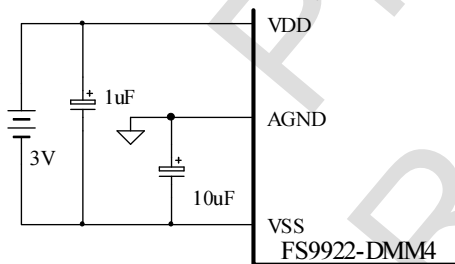

Diagram 7: 3V Power Supply

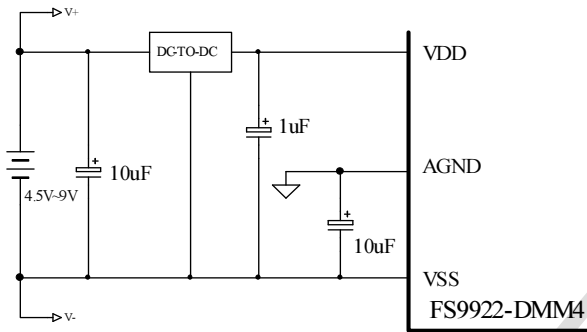

Diagram 8: 4.5V~9V Power Supply

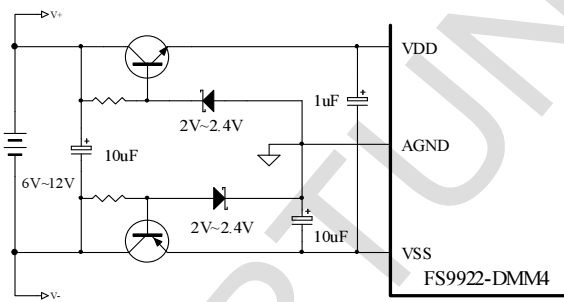

Diagram 9: 6V~12V Power Supply

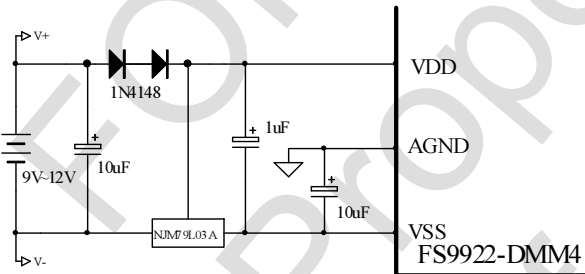

Diagram 10: 9V~12V Power Supply

Base Power Source

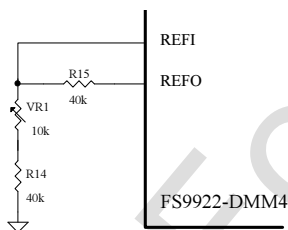

Diagram 11: The Utility of Internal Base Power Source

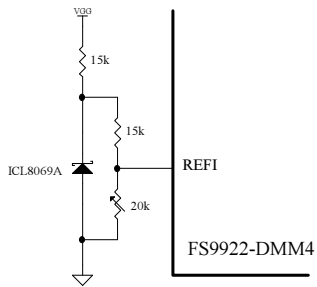

Diagram 12: The Utility of External Base Power Source

Trigger Reset Circuit

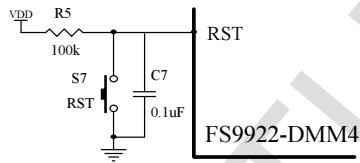

Diagram 13: Reset Circuit

Note: 1. R5 and C7 are the components for reset, which will automatically reset when power on.
 2. S7 is the key for manual reset. May not use it if the manual reset function is not necessary.

Oscillation Circuit

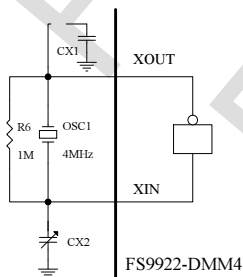

Diagram 14: Oscillation Circuit

In the diagram, R6 is the reverser to provide the static working point; CX2 is the fine adjustment of frequency; CX1 is temperature offset. In less requirements situation, CX1 and CX2 can be unused.

Buzzer Driver Circuit

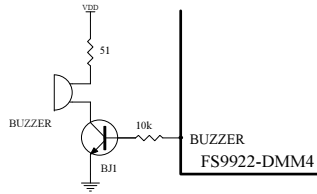

Diagram 15: Low Resistance Buzzer Connection

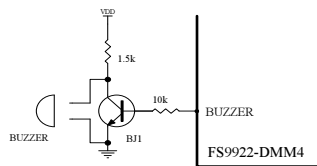

Diagram 16: High Resistance Buzzer Connection

Mode Switch and Function Control Circuit

For Mode Switch and Function Control, please refer to Diagram 17.

KP1~KP5 are mode switches which are the lock switches. For their functions, please refer to “Measurement Modes Select”. S1~S6 are the trigger keys. For their functions, please refer to “Keys Definition” and “Other Functions”. In practical application, it depends on the actual situation to decide which switches and keys.

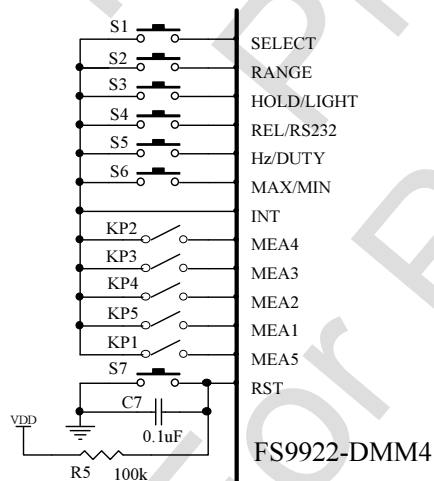

Diagram 17: Mode Switch and Function Control Circuit

AC Rectification Circuit

Diagram 18 is the average value rectification circuitry of FS9922-DMM4. In the circuit, AC signals enter IC through R31, and then in the process of voltage division through R31, R30, R29, R28 and R27. The divided AC signals come out from OP10 pin and enter IC through ADIP pin and ADIN pin after rectification. VR2 can adjust the signal size to be the calibration of AC measurement.

Diagram 19 is the peak value rectification circuitry. Diagrams 20 and 21 are the true valid value rectification circuitry. Users may determine which rectification circuit to select according to their needs.

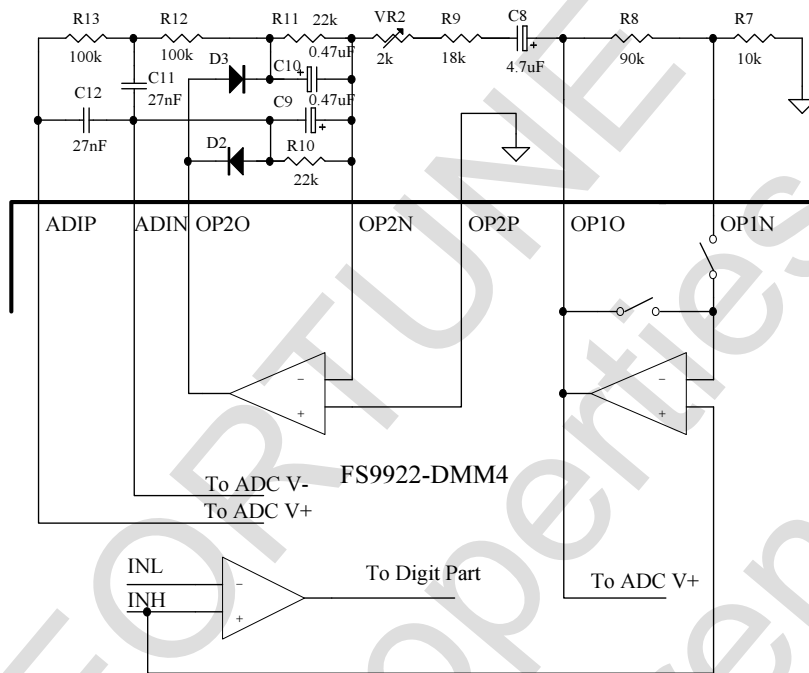

Diagram 18: Average Rectification Circuit

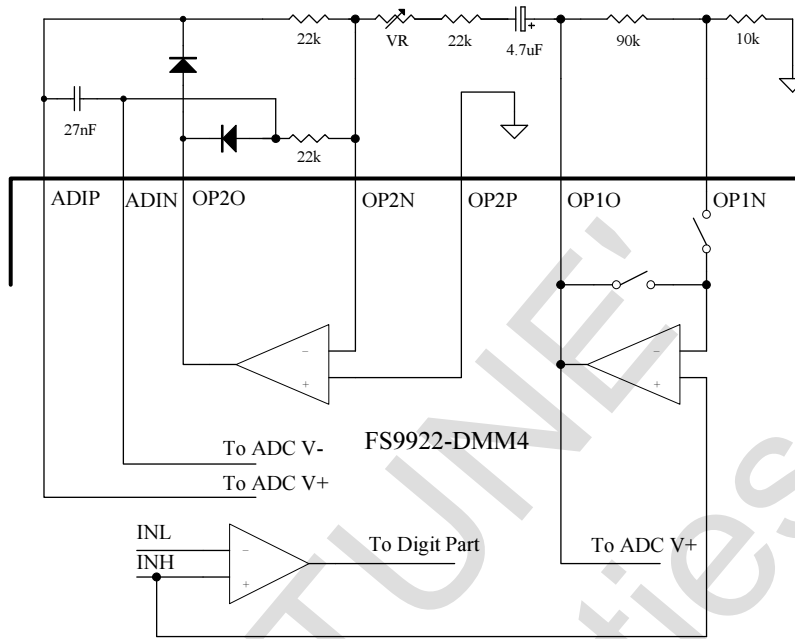

Diagram 19: Peak Value Rectification Circuit

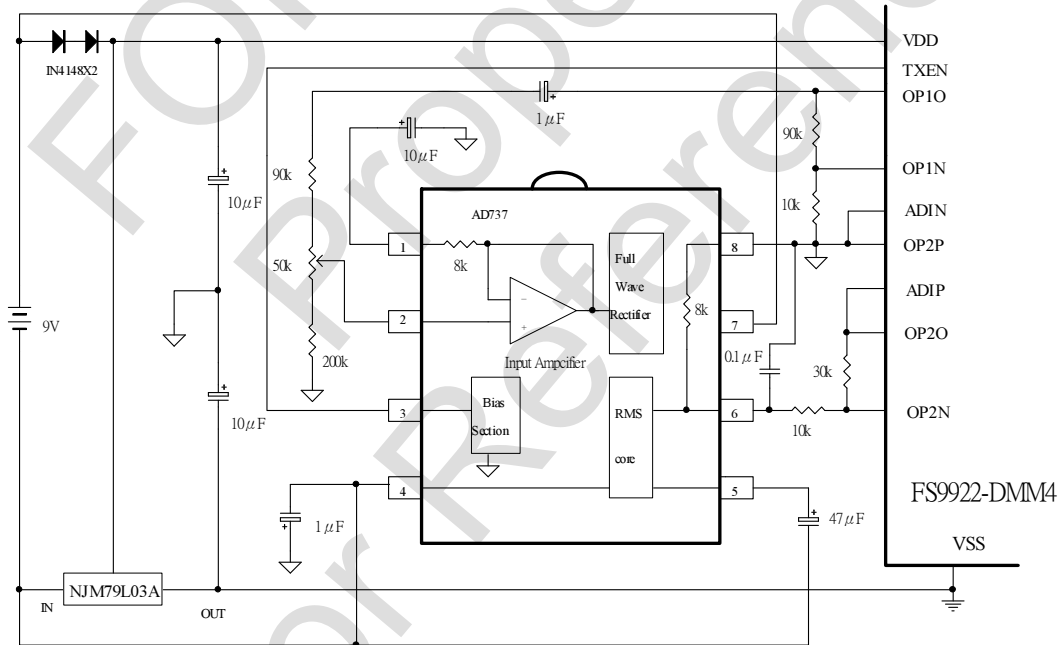

Diagram 20: True Valid Value Rectification Circuit (A)

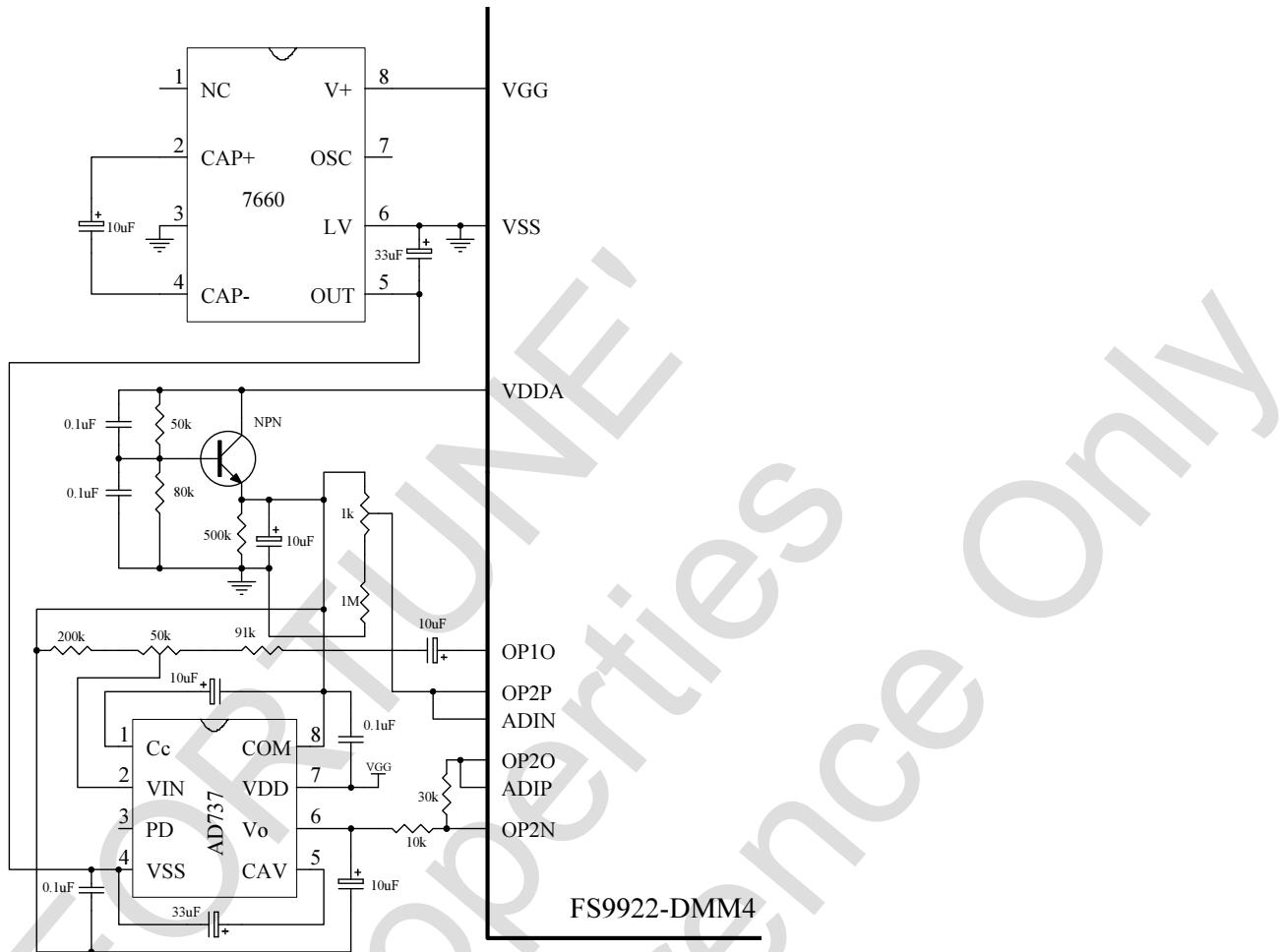

Diagram 21: True Valid Value Rectification Circuit (B)

Voltage Measurement

Please refer to Diagram 22 for Voltage Measurement.

When doing the voltage measurement, the measured voltage is input from resistance R31, and DCmV is not divided but enter IC directly; the mode voltages of 6V, 60V, 600V, 6000V are divided by R30, R29, R28, R27 and R31 to gain 1/10, 1/100, 1/1000, 1/10000 of the input voltages, then enter IC.

Single AC and DC 60mV/600mV voltage is input by SA.

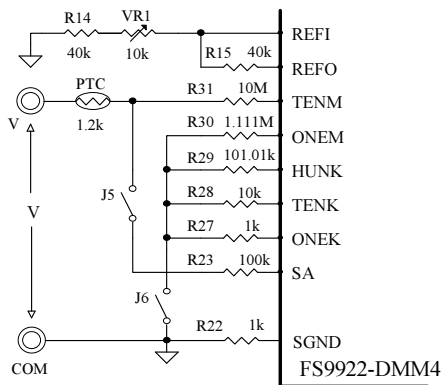

Diagram 22: Voltage Measurement

The formula of voltage division is: $V_{out} = V_{in} \times [R_s / (R_{s1} + R_s)]$
 Rs is R30、R29、R28 or R27.

Therefore, the accuracy of R27, R28, R29, R30 and R31 decides the accuracy of each measurement. Please refer to Diagram 23 for Voltage Division Circuit.

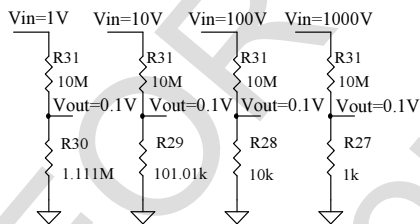

Diagram 23: Voltage Division Circuit

AC/DC mV Voltage Measurement

Please refer to Diagram 24 for AC/DC mV Voltage Measurement.

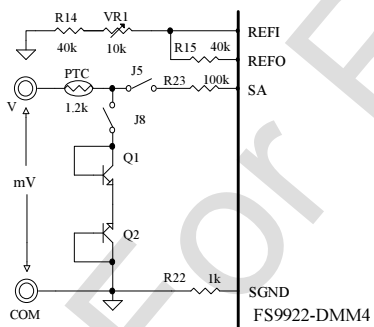

Diagram 24: 60mV/600mV Voltage Measurement

Current Measurement

Please refer to Diagram 25 for Current Measurement.

When doing the current measurement, the current signals enter IC through R23.

The sampling resistance of μA mode is $R21+R20+R19$, the sampling resistance of mA mode is $R20+R19$, and the sampling resistance of 60A mode is $R19$. They are measured respectively through the mode switch. When measuring μA , J2 is close; when measuring mA, J2 and J3 are close; when measuring the bulk current of 40A mode, J3 is close.

The maximum reduced voltage generated by μA , mA and 60A modes is 300mV. The accuracy of R21, R20 and R19 influences the accuracy of current measurement.

Note: The max. reduced voltage is 600mV when the current measurement is under the code No. 00100 · 01000 · 00011 and 00101.

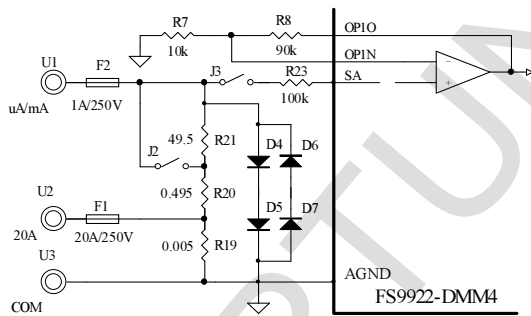

Diagram 25: Current Measurement

Clamp Meter Circuit

Please refer to Diagram 26 for Clamp Meter Measurement Circuit.

When FS9922-DMM4 is applied to Clamp Meter, the AC/DC sampling signals of 6.000A · 60.00A · 600.0A and 6000A are input from SA and AGND, and the full scale value is 400mV RMS.

Diagram 26 indicates only the AC application.

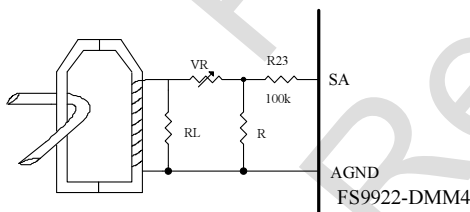

Diagram 26: Clamp Meter Circuit

Resistance Measurement

Please refer to Diagram 27 for Resistance Measurement.

Resistance measurement refers to the standard resistance, and then takes a comparison between the resistance to be measured and the standard resistance to get the measured resistance value. The standard resistance of 60MΩ mode is 10MΩ (R31). The standard resistance of other modes are R31 to parallel respectively with R30, R29, R28 and R27 to get 1MΩ, 100kΩ, 10kΩ, 1kΩ resistance. When doing resistance measurement, internal IC will generate 0.63V voltage (relative to AGND), the voltage is output respectively to the resistance to be measured through resistance R31, R30, R29, R28 and R27.

R26 connects to RL, which is the negative input of the referenced voltage from the standard resistance. J7 and J10 are mode switches. When doing resistance measurement, J7 and J10 are close.

C15 is the wave filter capacitance of the point to be measured in resistance measurement.

Note:

1. Use SELECT Key can choose Hi Measurement Mode, 600.0MΩ and 6000MΩ Mode can proceed Auto Measurement. Use RANGE Key during Hi Measurement Mode can select 600.0MΩ and 6000MΩ Mode to proceed Manual Measurement.
2. The referenced resistance of 600.0MΩ and 6000MΩ Mode is R31 (10MΩ), the accuracy of the two Measurement Modes is depending on the referenced resistance, and greatly related to the PCB quality and the integration skill.
3. In order to guarantee that the 600.0MΩ and 6000MΩ Mode have respectively the accuracy of $\pm 2\% \times \text{reading}$ and $\pm 5\% \times \text{reading}$, the insulation resistance at Input of Resistance Measurement shall be larger than 30,000MΩ and 120,000MΩ.

If the PCB quality is not good enough or the integration skill can not guarantee the a. m. requirements, the 600.0MΩ and 6000MΩ Measurement Mode shall not be set then.

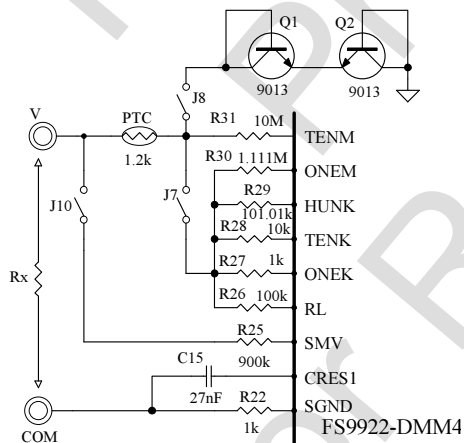

Diagram 27: Resistance Measurement

Diode Test

Please refer to Diagram 28 for Diode Test.

During the Diode test, 2.7V voltage (relative to AGND) is generated from IC internal, and output through R27, then added to the positive of diode through PTC. The positive reduced voltage VD generated by diode is approx. 0.5V-2.0V. VD is divided by R25 and R26 to be 1/10 of VD, and then amplified 10 times by internal OP to display the VD value. J10 and J7 are mode switches, which are close during diode measurement.

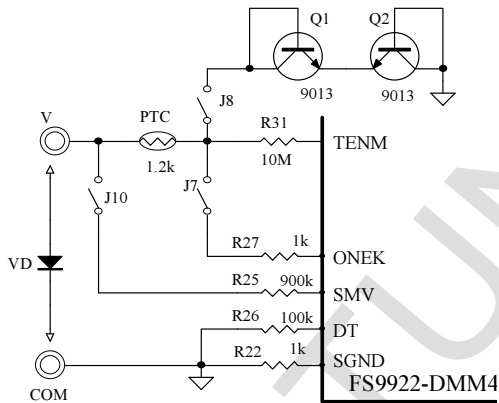

Diagram 28: Diode Test

Continuity Test

Please refer to Diagram 29 for Continuity Test.

When doing the Continuity Test, the inner of IC will generate 0.63V voltage (relative to AGND), output from R27, and is added to open-short measuring point through PTC. J10 and J7 are mode switches, which are closed during the Continuity Test. Rx gets voltage VRx, and enters IC through R25. From the diagram we know that $R_x = (R_{27} + PTC) / 50$

So, the resistance value of PTC will influence the top limit of the resistance during Continuity Test. When PTC is not connected, the resistance of the buzzer sound is smaller than 30Ω, if R27 is 1kΩ.

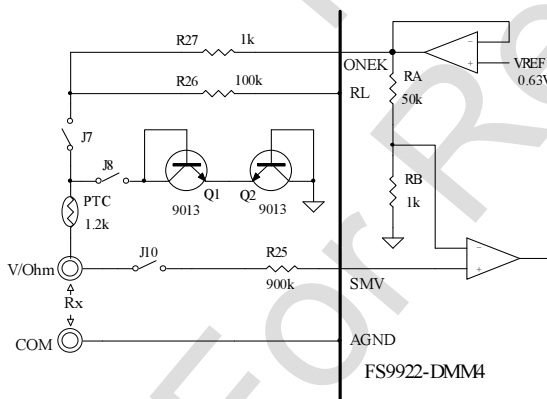
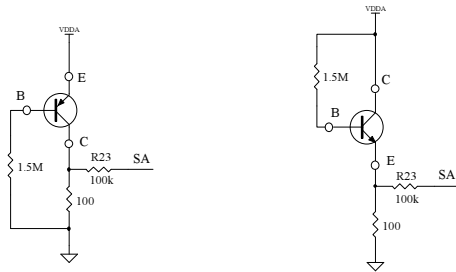

Diagram 29: Continuity Test

Transistor hFE Test

Please refer to Diagram 30 for Transistor hFE Test.



PNP Type Transistor

NPN Type Transistor

Diagram 30: Transistor hFE Test

Capacitance Measurement

Please refer to Diagram 31 for Capacitance Measurement.

Capacitance Measurement is to create oscillation by charging and discharging the measured capacitance through R33 or R32, and to find out the capacitance value by calculating the oscillation cycle. The capacitance measurement reading value can be calibrated through the adjustment of VR3 or VR4. J10 and J7 are mode switches, which are closed during Capacitance measurement.

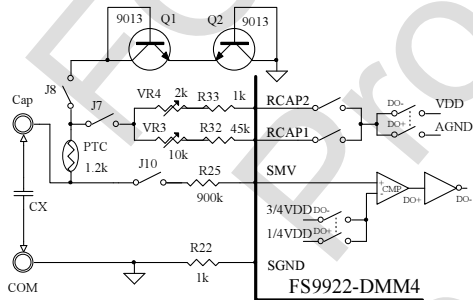

Typical Wave at Input

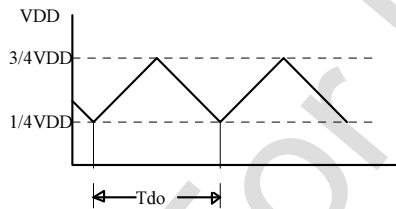

Diagram 31: Capacitance Measurement

Frequency Measurement

Please refer to Diagram 32 for Frequency Measurement.

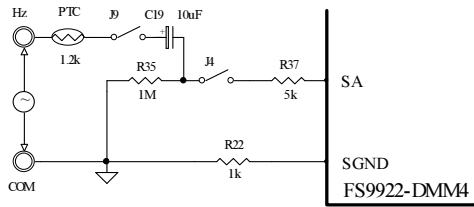

Diagram 32: Frequency Measurement

High Frequency Measurement

Please refer to Diagram 33 for High Frequency Measurement.

High Frequency component shall be used for 10MHz~1000MHz High Frequency Measurement.

High Frequency component is a device to make 128 frequency division after reforming the high frequency, the impulse amplitude shall be above 200mV RMS after frequency division.

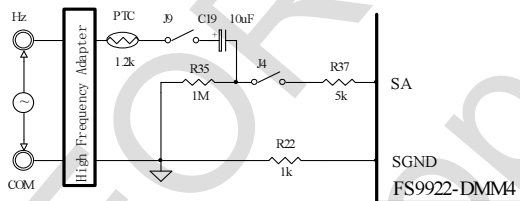

Diagram 33: High Frequency Measurement

RPM Measurement

Please refer to Diagram 34 for RPM Measurement.

RPM component shall be used for RPM Measurement.

RPM component is a device to transform RPM into electrical impulse, the output impulse amplitude shall be above 200mV RMS.

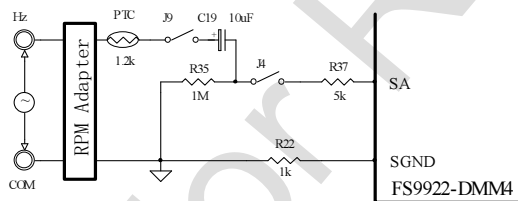

Diagram 34: RPM Measurement

Temperature Measurement

Please refer to Diagram 35 for Temperature Measurement.

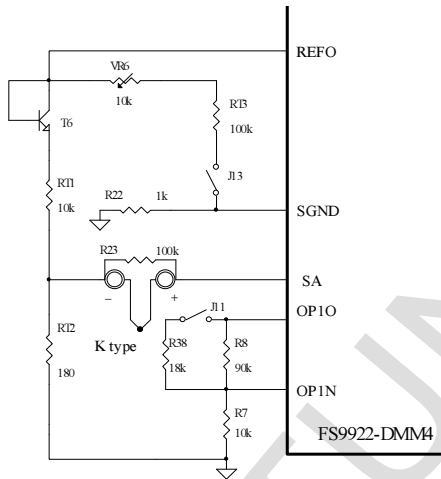

Diagram 35: Temperature Measurement

Description of Diagram 35:

- 1) Diagram 35 the temperature test circuit is for reference only; besides, it is only for the K type thermocouple. No decimal point under Code No. 11111 temperature measurement mode.
- 2) A. In the application of the circuit in Diagram 35, since there is a minor deviation between each IC's referenced voltage, different model of Transistor are adopted for Diode, PN joint's voltage/temperature properties are also different, resulting in different compensation effect at the cold point. Therefore, proper adjustments shall be taken to RT1 · RT2 and RT3.
 B. V6 is adjusted to 0°C, R38 to be the high point, the scale of K type thermocouple is about 40μV/°C each. Therefore, the OP amplifying time is 2.5.
 C: If other thermocouples are used for temperature sensors, users can adjust properly the OP amplifying times according to the Diagram 35.
- 3) There are two measurement process -273.0°C~+400.0°C (-459.4°F ,+752.0°F) and -273°C~+ 4000°C(-459°F ,+7232°F) in the Code No. (10111) and (01110) Measurement Mode, which are under the Auto Measurement Mode. To -273.0°C~+400.0°C measurement process, the corresponding scale value is 10.0°C/mV each; to -273°C~+ 4000°C measurement process, the corresponding scale value is 10°C/mV. Therefore, OPs with different amplifying time shall be used respectively depending on different kinds of temperature sensors to reach the requirement of 10.0°C/mV and 10°C/mV. The corresponding °F will be calculated out automatically by referring to °C .

13. RS232 Transmission Specification

RS232 transmission format is 14 byte. Its transmission rate is 2400 bps. The format is as follow:

Sing	Data Byte	Space	Point	SB1	SB2	SB3	SB4	BAR	EOF	ENTER
------	-----------	-------	-------	-----	-----	-----	-----	-----	-----	-------

1	2	3	4	5	6	7	8	9	10	11	12	13	14
+/-	X	X	X	X	020H	X	X	X	X	X	X	00DH	00AH

14 byte output code location:

- a) Sing byte 1: 0f0H ;
- b) Data byte 2: 0f1H ;
- c) Data byte 3: 0f2H ;
- d) Data byte 4: 0f3H ;
- e) Data byte 5: 0f4H ;
- f) Space byte: 0f5H ;
- g) Point byte: 0f6H ;
- h) SB1 byte: 0f7H ;
- i) SB2 byte: 0f8H ;
- j) SB3 byte: 0f9H ;
- k) SB4 byte: 0faH ;
- l) BAR byte: 0fbH ;
- m) EOF byte: 0fcH ;
- n) ENTER byte: 0fdH .

Sing byte stands for the positive or negative sign of DMM measuring signal, and its output code is ASCII code:

- a) positive (+) : 02BH
- b) negative (-) : 02DH.

Data byte is 4 byte that stands for DMM measured data, and its output code is ASCII code:

- a) Date byte 2: stands for Lcd_1 ;
- b) Date byte 3: stands for Lcd_2 ;
- c) Date byte 4: stands for Lcd_3 ;
- d) Date byte 5: stands for Lcd_4 .

Point Byte stands for the decimal location, and its output code is Hex code:

- a)Point 「0」 : 030H stands for no decimal and LCDs 『 0000 』 ;
- b)Point 「1」 : 031H stands for no decimal and LCDs 『 0.000 』 ;
- c)Point 「2」 : 032H stands for no decimal and LCDs 『 00.00 』 ;
- d)Point 「3」 : 033H stands for no decimal and LCDs 『 000.0 』 .

SB1 Byte code is as follow (SB1), and its output code is Hex code:

Status	Bit7	Bit6	Bit5	Bit4	Bit3	Bit2	Bit1	Bit0
0								
1	0	0	AUTO	DC	AC	REL	HOLD	BPN

SB2 Byte code is as follow (SB2), and its output code is Hex code:

Status	Bit7	Bit6	Bit5	Bit4	Bit3	Bit2	Bit1	Bit0
0								
1	Z1	Z2	MAX	MIN	APO	Bat	n	Z3

SB3 Byte code is as follow (SB3), and its output code is Hex code:

Status	Bit7	Bit6	Bit5	Bit4	Bit3	Bit2	Bit1	Bit0
0								
1	μ	m	k	M	Beep	Diode	%	Z4

SB4 Byte code is as follow (SB4), and its output code is Hex code:

Status	Bit7	Bit6	Bit5	Bit4	Bit3	Bit2	Bit1	Bit0
0								
1	V	A	Ω	hFE	Hz	F	°C	°F

Bar byte: Bit 7 stands for the positive or negative; Bit 0~6 stands for Bar graph number. Its output code is Hex code.

Example: measuring voltage mode 『MEAS: 11010』 : input 0V. LCD is as follow:

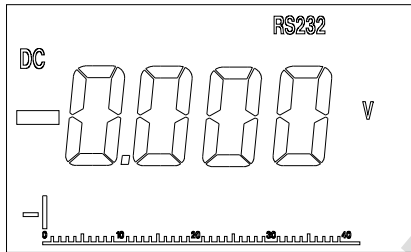

RS232 Output Format:

2D-30-30-30-30-20-31-11-00-00-80-80-0D-0A

RS232 Output Wave Form

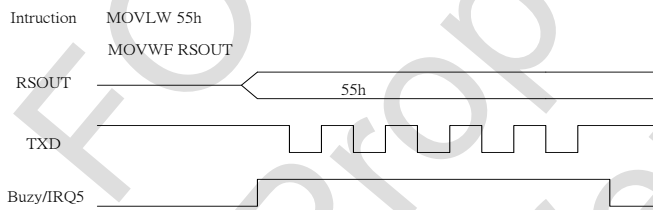

Diagram36 RS232 Output Wave Form

14. LCD

Plane Structure of LCD

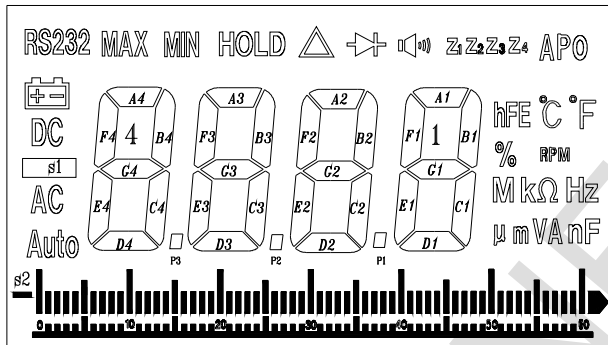

Diagram37 LCD Diagram

Table of True Valid Value of LCD

LCD PIN	1	2	3	4	5	6	7	8	9
IC PIN	COM1	COM2	COM3	COM4	SEG1	SEG2	SEG3	SEG4	SEG5
COM4				COM4	LB	RS232	Auto	MAX	F4
COM3			COM3		S1	S2	DC	AC	E4
COM2		COM2			BP0	BP1	BP3	BP5	BP7
COM1	COM1				BPN	BP2	BP4	BP6	BP8

LCD PIN	10	11	12	13	14	15	16	17	18
IC PIN	SEG6	SEG7	SEG8	SEG9	SEG10	SEG11	SEG12	SEG13	SEG14
COM4	A4	B4	MIN	F3	A3	B3	HOLD	F2	A2
COM3	G4	C4	P3	E3	G3	C3	P2	E2	G2
COM2	D4	BP10	BP12	BP14	D3	BP17	BP19	BP21	D2
COM1	BP9	BP11	BP13	BP15	BP16	BP18	BP20	BP22	BP23

LCD PIN	19	20	21	22	23	24	25	26	27
IC PIN	SEG15	SEG16	SEG17	SEG18	SEG19	SEG20	SEG21	SEG22	SEG23
COM4	B2	△	F1	A1	B1	DIODE	CONT	Z1	Z2
COM3	C2	P1	E1	G1	C1	μ	m	V	A
COM2	BP24	BP26	BP28	D1	BP31	BP33	BP35	BP37	BP39
COM1	BP25	BP27	BP29	BP30	BP32	BP34	BP36	BP38	BP40

LCD PIN	28	29	30	31	32	33	34	35	36
IC PIN	SEG24	SEG25	SEG26	SEG27	SEG28	SEG29	SEG30	SEG31	SEG32
COM4	Z3	Z4	APO	hFE	°C	°F	%	Hi	BP60
COM3	n	F	M	k	Ω	Hz	RPM		BP59
COM2	BP41	BP43	BP45	BP47	BP49	BP51	BP53	BP56	BP58
COM1	BP42	BP44	BP46	BP48	BP50	BP52	BP54	BP55	BP57

Description:

1. BPN is the rule of Bar graph (0, 10, 20, 30, 40)
2. BP is the scale of Bar graph. The first left is BP0, then to right are BP1, BP2....., and so on, the most right including the arrow is BP40.

Description of Symbols of LCD

Symbol	Description	Symbol	Description	Symbol	Description
	Low Battery	HOLD	Data Hold	RPM	Round Per Minute
AUTO	Auto Measure	MAX, MIN	Max./Min. Value Hold	%	Impulse Signal / Duty Cycle Percentage
AC	AC	Δ	Relative Value Measure	APO	Auto Power Off
DC	DC	mV · V	Voltage Unit	hFE	Transistor DC amplifying times
	Negative	μ A · mA · A	Current Unit	Hi	High Resistance or High Frequency Measurement Mode
RS232	Data Output	Ω · k Ω · M Ω	Resistance Unit	Z1 Z2 Z3 Z4	User Defined Symbols
	Diode	nF · μ F	Capacitance Unit		
	Continuity	Hz · kHz · MHz	Frequency Unit		

15. Package Outline & Pad Assignment

Package Outline

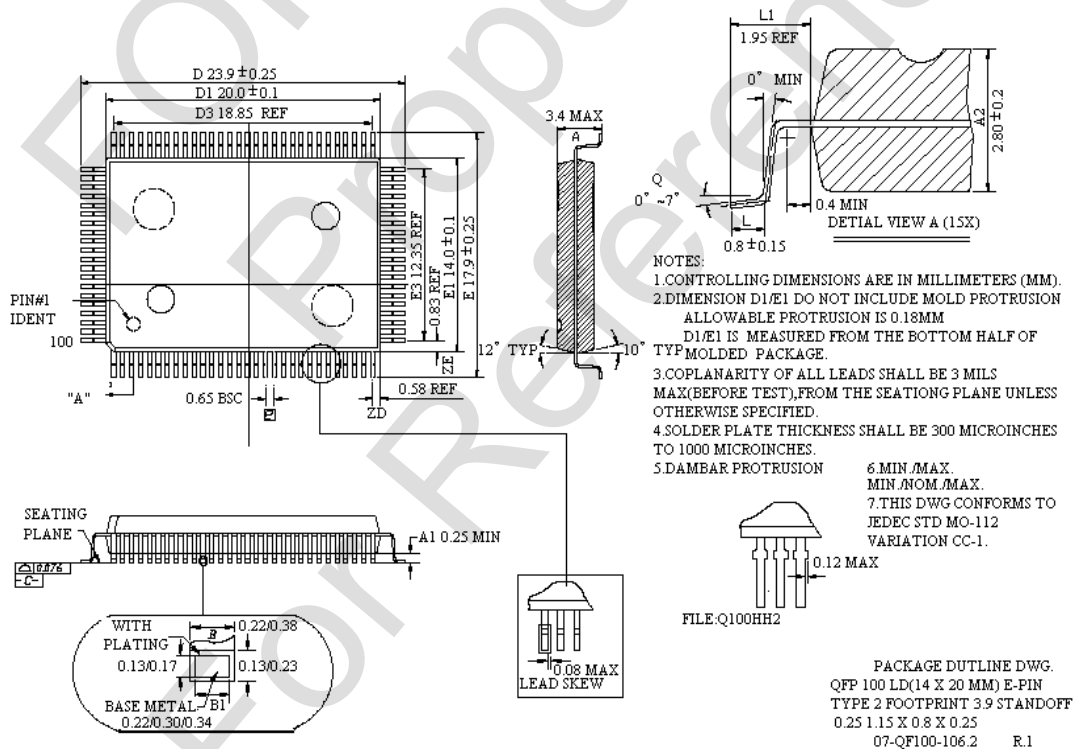
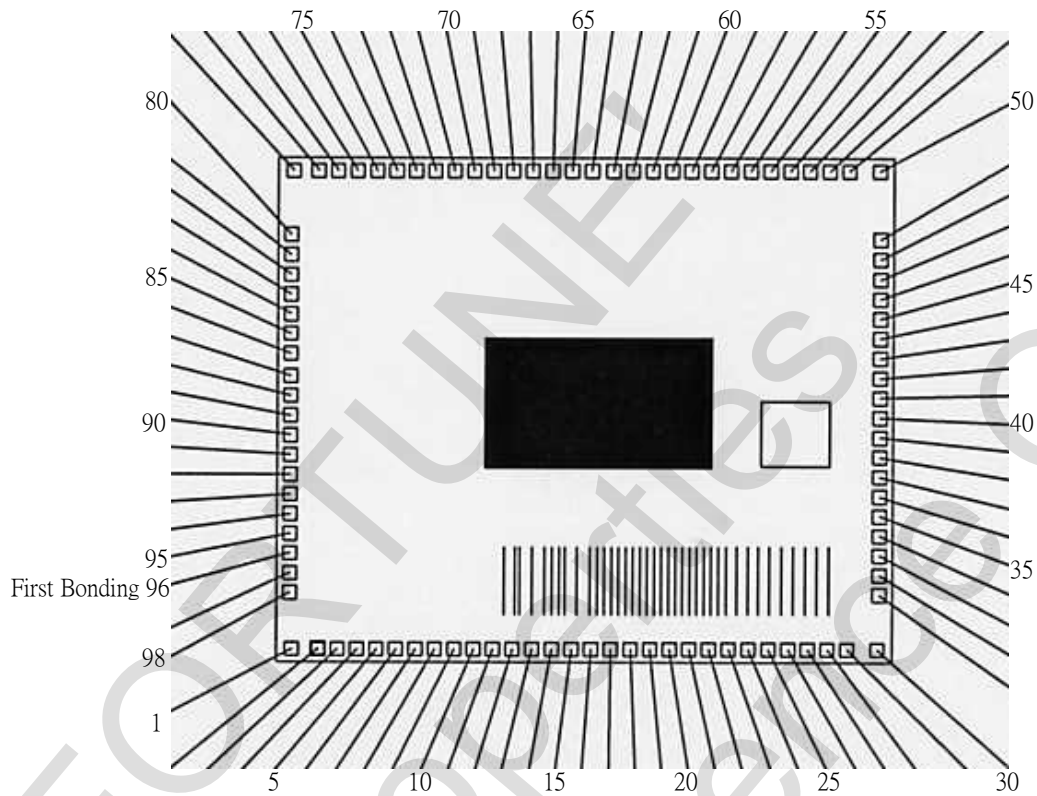

Diagram 38: Package Outline

Pad Assignment



Pad Opening: 90 μm
 Chip size: 3455 X 2811 (μm)
 Note: Substrate should be connected to VSS

Diagram 39: Pad Assignment

Pad Coordination

Pad No.	Name	X [μm]	Y [μm]	Pad No.	Name	X [μm]	Y [μm]	Pad No.	Name	X [μm]	Y [μm]
1	OP2O	86	72	34	SEG29	3382	711	67	RLCD	1434	2739
2	OP2N	231	72	35	SEG28	3382	821	68	VDDA	1324	2739
3	OP2P	341	72	36	SEG27	3382	931	69	VGG	1214	2739
4	REFO	451	72	37	SEG26	3382	1041	70	CA	1104	2739
5	REFI	561	72	38	SEG25	3382	1151	71	CB	994	2739
6	FTC2	671	72	39	SEG24	3382	1261	72	VDD	884	2739
7	FTB2	781	72	40	SEG23	3382	1371	73	BUZZER	774	2739
8	FTC1	891	72	41	SEG22	3382	1481	74	LBOUT	664	2739
9	FTB1	1001	72	42	SEG21	3382	1591	75	MAX/MIN	554	2739
10	ADP2	1111	72	43	SEG20	3382	1701	76	Hz/DUTY	444	2739
11	ADP	1221	72	44	SEG19	3382	1811	77	REL/RS232	334	2739
12	AD1P	1331	72	45	SEG18	3382	1921	78	HOLD/LIGHT	224	2739
13	AD1N	1441	72	46	SEG17	3382	2031	79	RANGE	85	2739
14	SGND	1551	72	47	SEG16	3382	2141	80	SELECT	72	2385
15	SA	1661	72	48	SEG15	3382	2251	81	XOUT2	72	2275
16	DT	1771	72	49	SEG14	3382	2361	82	XIN2	72	2165
17	SMV	1881	72	50	SEG13	3376	2739	83	TST	72	2055
18	CRES1	1991	72	51	SEG12	3204	2739	84	RST	72	1945
19	RL	2101	72	52	SEG11	3094	2739	85	PWDT	72	1835
20	RCAP1	2211	72	53	SEG10	2984	2739	86	XOUT1	72	1725
21	RCAP2	2321	72	54	SEG9	2874	2739	87	XIN1	72	1600
22	ONEK	2432	72	55	SEG8	2764	2739	88	MEA4	72	1490
23	TENK	2542	72	56	SEG7	2654	2739	89	MEA3	72	1380
24	HUNK	2552	72	57	SEG6	2544	2739	90	MEA2	72	1270
25	ONEM	2762	72	58	SEG5	2434	2739	91	MEA1	72	1160
26	TENM	2872	72	59	SEG4	2324	2739	92	TXD	72	1050
27	TENM2	2982	72	60	SEG3	2214	2739	93	MEA5	72	940
28	CRES2	3092	72	61	SEG2	2104	2739	94	TXEN	72	830
29	VB	3202	72	62	SEG1	1994	2739	95	INT	72	720
30	AGND	3372	72	63	COM4	1874	2739	96	VSS	72	610
31	SEG32	3382	381	64	COM3	1764	2739	97	OP1N	72	500
32	SEG31	3382	491	65	COM2	1654	2739	98	OP1O	72	390
33	SEG30	3382	601	66	COM1	1544	2739				

16. Ordering Information

Product Number FS9922-DMM4	Package Type Dice form (98 pins), 100-pin QFP
--------------------------------------	---

17. Revision History

Ver.	Date	Page	Description
1.0	2005/03/17	-	1. IC is in production; revise the data sheet version to 1.0. Nothing changed compared with the last version. 2. Document is corresponding to Simplified Chinese version 1.0.
1.1	2006/09/15	6、11、32	Use -273.0°C instead of -400.0°C and use -273°C instead of -400°C.
		22	Revise the diagram 20, True Valid Value Rectification Circuit.
1.2	2014/05/22	2	Revised company address
1.3	2015/03/12	6	Diagram 1.

FORTUNE
Properties
For Reference Only