



ASKPOWER A131 Series User's Guide
Safety energy-saving variable frequency speed governor

Preface

Version: 1.74

Thank you very much for choosing high quality, multifunction, low level noise and energy cost product by Isacon Power Control Tech. Co., Ltd -- A131 series inverters.

This manual contains the user setup, parameter setting, fault diagnosis, daily maintenance and safety precautions. Please read this manual carefully before installing and operating the products. This manual is contained in the accessories of the productions. Please keep it safe for further referencing.

If there is any problem which isn't listed in this manual, please contact the local dealer or Isacon's custom service center.

Phone: 0086-576-87161633-Department of Technology(10 Line)

Fax.: 0086-576-87161633-8005

Contents

第一章	Safety Precautions	2
第二章	User Setup	4
第三章	Control Panel	7
第四章	Parameter Set Method	8
第五章	Table of Configure Parameters	9
第六章	Description of Control Ports	11
第七章	Description of Configure Parameters	12
第八章	Operation Examples	17
第九章	Data Formation of Serial Ports	18
第十章	Error Message and Fault Diagnosis	20
第十一章	Maintenance and Repair	22
第十二章	Braking Component and Capability	25
第十三章	Type Description	26

Chapter 1 Safety Precautions

1.1 Safety precautions

- Environment cannot contain any explosive gas.
- It must be wired by professional wiring staff. Otherwise, it may cause electronic shock.
- Cut off the power supply before wiring. Otherwise, it may cause electronic shock.
- Do not touch any control port, internal boards and their electronic components while the electricity is turned on. Otherwise, it may cause electronic shock.
- Please make sure that the product's ground wiring port is correctly connected according to national electricity safety standards or other related standards.
- Do not touch any internal board or component until 10 minutes after power shutdown. Please do electricity check before internal board maintenance. Otherwise, it may cause electronic shock.
- It is forbidden to connect AC power to product's output port (U,V,W) or other control ports except Lk,Lb,Lz. Otherwise, it may cause damage to the inverter.
- Since internal IC can be destroyed by electrostatic, please do not touch any PCB, IC or IGBT components without any protection. Otherwise, it may cause unknown fault.
- Make sure that any unexpected conductor such as screws, gasket, etc., is not left inside the inverter during maintenance. Otherwise, it may cause damage to the inverter or even fire.
- If overcurrent happens during starting up, please check the wiring and start up again.
- Do not stop machine by cut off power. Power can be cut off after the motor stops.
- Do not leave inverter in the sunshine. Otherwise, it may cause damage to the inverter.

1.2 Package inspection

A131 series inverter production undergoes strictly qualification test. Please check the damage caused by delivery and the type specification during package inspection.

- Accessories: 1 Inverter, 1 user manual.
- If anything is missing, please contact local dealer or Isacon's custom service center.

Chapter 2 User Setup

2.1 Environment requirement

- No corrosive gas, vapour and oily dust. Without direct sunshine.
- No floating dust or mental particle.
- Air moisture 20%~90%.
- Vibration $< 5.8\text{m/s}^2(0.6\text{g})$.
- No electromagnetic interference.
- Temperature: $-10^{\circ}\text{C}\sim 50^{\circ}\text{C}$, make sure proper ventilation if the temperature is greater than 40°C .
- Without any inflammable or explosive gas, liquid and solid.
- Please use electric cabinet or remote operation in non-standard environment. Make sure proper ventilation.

2.2 Install space

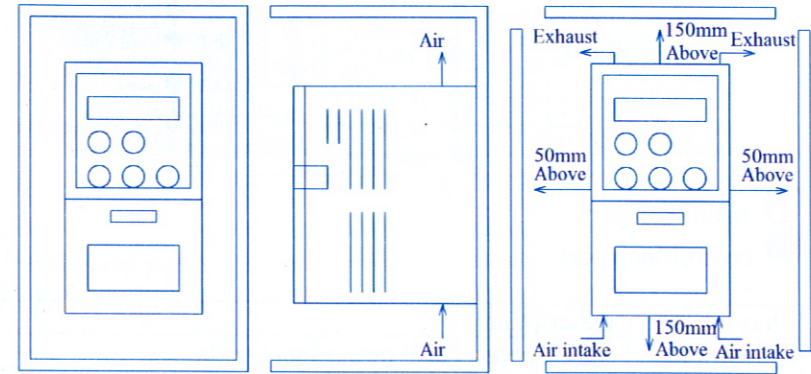

2.3 Basic wiring

There are two wiring part: main-loop and control-loop. Please do wiring correctly according to the following two figures.

Wiring Figure (single phase)

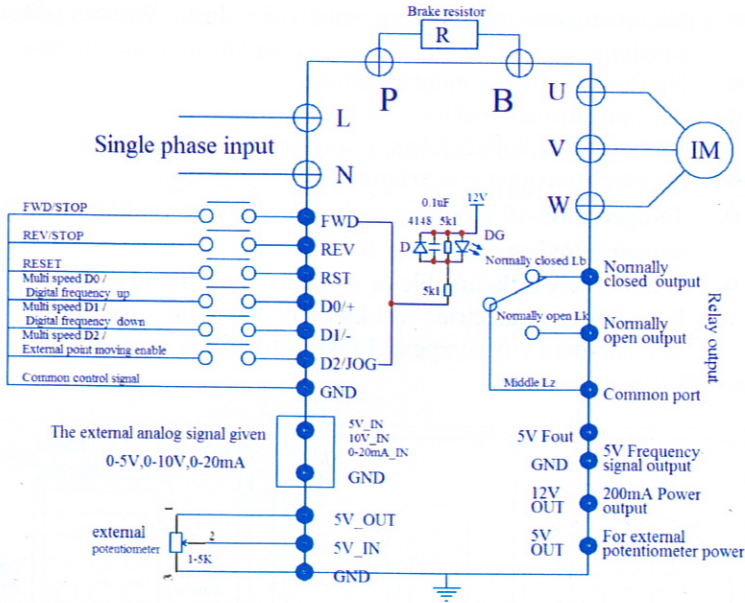

⊕ main-loop port
● control-loop port

Port name	Description
L. N	Single phase 220V power input ports
U. V. W	Three phase AC output ports can only connect to pure resistance or inductance load such as motors or electric heater.
P	Braking resistance positive polarity.
B	Braking resistance negative polarity.

Wiring figure (three phase)

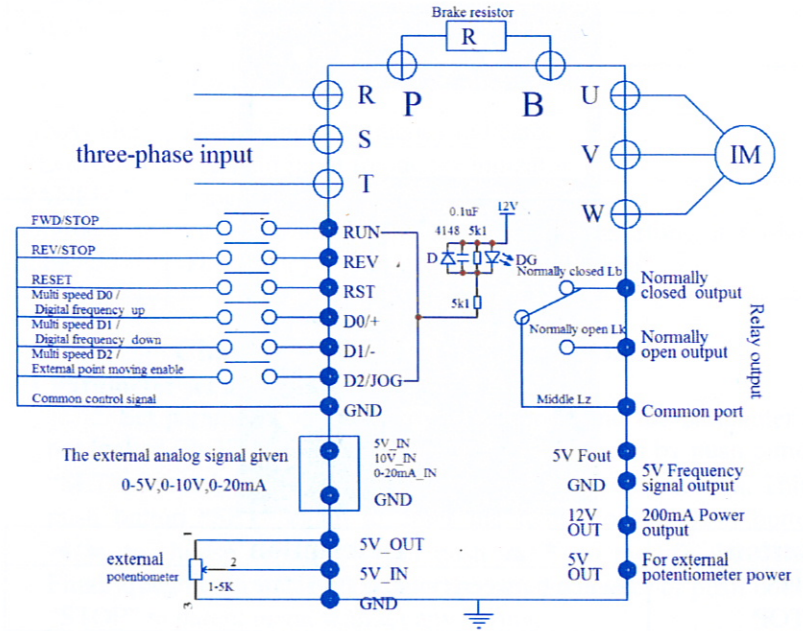

⊕ main-loop port
● control-loop port

Port name	Description
R S T	Three phase 380V or 220V power input ports
U V W	Three phase AC output ports can only connect to pure resistance or inductance load such as motors or electric heater.
P	Braking resistance positive polarity.
B	Braking resistance negative polarity.

Chapter 3 Control Panel



Button	Description
RUN STOP	Switch between run and stop state by single press.
STOP RESET	It has different meanings to push this button during different modes: 1.if the inverter is running, it would stop; 2. If a fault happens, the inverter would be reset; 3. If it is operated on menus, it returns to parent menu.
REV	Change the inverter's direction. It also works during the runtime.
SET	Enter menu mode. If it is on item, the data would be saved and lower level menu would be displayed.
▲▼	Change items in the menu or modify the parameter data.
◀▶	Modify the menu content and point move in panel.
Potentiometer	Change runtime frequency.

Content	Description
ERROR	Fault indicator.
FWD	Clockwise rotation indicator.
REV	Anticlockwise rotation indicator.
ANALOG	Analog input frequency indicator.
SEGMENT	Segment input frequency indicator.
PANEL	Panel input frequency indicator.
Digital tube	Inverter runtime frequency. If inverter stops, it flashes. The display data is given by "Pn01" data.

Chapter 4 Parameter Set Method

4.1 Parameter set and modification

Set parameter when inverter is stopped and the parameter is not locked (Pn32=1). First, enter parameter set menu by push button "SET". Second, push button ▲/▼ to choose the certain item. Third, push button "SET" again to enter the item. Fourth, push button ◀/▶ to choose certain bit and push ▲/▼ to modify the value. Finally, push button "SET" to save the new parameter or push button "STOP" to parent menu without any saving.

Push button "SET" to save the new parameter or push button "STOP" to parent menu without any saving.

4.2 Button notice

When modify parameters, long push ▲/▼ to rolling number of current bit between 0-9.

Chapter 5 Table of Configure Parameters

Item	Description Modify by button ▲ or ▼	Range Modify by button ▲ or ▼	Default Value
Pn 01	Default display content	1—60	1
Pn 02	Initial start up frequency by panel or other method	0.01—400.00	50
Pn 03	Source of runtime frequency	1—7	1
Pn 04	Source of runtime command	1—2	1
Pn 05	clockwise / anticlockwise disable	1—3	3
Pn 06	Method to stop inverter	1—2	2
Pn 07	Start again by external signal	1—2	1
Pn 08	Acceleration time	000.01S—650.00S	10S
Pn 09	Deceleration time	000.01S—650.00S	10S
Pn 10	Maximum runtime frequency	000.10Hz—400.00Hz	40Hz
Pn 11	Minimum runtime frequency	000.10Hz—400.00Hz	1.5Hz
Pn 12	Motor rating frequency	010.00Hz—400.00Hz	40Hz
Pn 13	Torque compensation	0.0—4.0	0.0
Pn 14	Torque compensation frequency	0.01Hz—400.00.00Hz	10Hz
Pn 15	Startup DC braking voltage	1V—100V	30V
Pn 16	Startup DC braking time	000.00S—650.00S	0S
Pn 17	Stop DC braking voltage	1V—100V	30V
Pn 18	Stop DC braking time	000.00S—650.00S	0S
Pn 19	Source of multi-segment speed 0	1—5	1
Pn 20	Multi-segment speed 1 frequency	000.10 Hz—400.00Hz	10
Pn 21	Multi-segment speed 2 frequency	000.10 Hz—400.00Hz	20
Pn 22	Multi-segment speed 3 frequency	000.10 Hz—400.00Hz	30
Pn 23	Multi-segment speed 4 frequency	000.10 Hz—400.00Hz	40

Item	Description Modify by button ▲ or ▼	Range Modify by button ▲ or ▼	Default Value
Pn 24	Multi-segment speed 5 frequency	000.10 Hz—400.00Hz	50
Pn 25	Multi-segment speed 6 frequency	000.10 Hz—400.00Hz	60
Pn 26	Multi-segment speed 7 frequency	000.10 Hz—400.00Hz	70
Pn 27	Point move frequency	000.10 Hz—400.00Hz	10Hz
Pn 28	Choice of relay output	1—6	3
Pn 29	2rd acceleration time	000.01S—650.00S	2S
Pn 30	2rd deceleration time	000.01S—650.00S	2S
Pn 31	2rd deceleration stop frequency	000.01Hz—400.00Hz	1Hz
Pn 32	Parameter management	1—3	1
Pn 33	Software version		
Pn 34	Auto recover while lost power suddenly	0—99Hz	0
Pn 35	Production date		

Please refer Chapter 7 for detail description of each item

Remark: If over-voltage happens during deceleration, it will stop.

Note:

If over-voltage happens during deceleration, inverter will stop deceleration until the voltage goes back to normal level. If better deceleration is needed, please switch to inverter with braking.

Chapter 6 Description of Control Ports

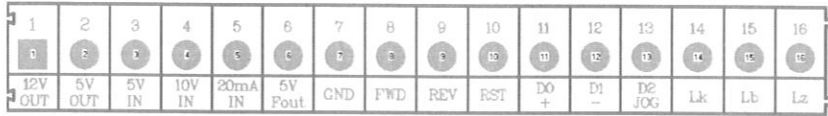

Port name	Port Description
12V OUT	12V output, with maximum currenncy 200mA.
5V OUT	5V output, with maximum currenncy 50mA.
5V IN	5V input, analog input, with maximum effective voltage 5V, no more than 6V
10V IN	10V input, analog input, with maximum effective voltage 10V, no more than 12V
20mA IN	20mA input, analog input, with maximum effective currenncy 20mA, no more than 25mA
5V Fout	Frequency signal output, maximum output voltage 5V
GND	Power source ground 0V.
FWD	External clockwise rotation input
REV	External anticlockwise rotation input
RST	External reset signal
D0 +	Multi-segment speed D0 input, external “+” signal means clockwise point move input
D1 -	Multi-segment speed D1 input, external “-” signal means anticlockwise point move input
D2 JOG	Multi-segment speed D2 input, external enable signal input
Lk	Relay ON
Lb	Relay OFF
Lz	Relay ON/OFF

Chapter 7 Description of Configure Parameters

Pn 01 Default display content: 1、2、4、6、8.....60

RUN: 1 means it will display runtime frequency
 Otherwise, it displays motor’s synchronization speed.
 2、4、6、8.....number of motor poles
 STOP: it will display frequency given by external signal.

Pn 02 Initial startup frequency by panel or other method

Range: 000.01Hz—400.00Hz, the initial panel data and external signal frequency during startup.

Pn 03 Source of runtime frequency with range: 1—7

1 Potentiometer 2 Panel button
 3 External 0-5V signal 4 External 0-10V signal
 5 External 0-20mA signal 6 External digital signal
 7 Multi-segment signal

Pn 04 Source of runtime command with range: 1—2

1 Panel button control 2 External signal control

Pn 05 clockwise / anticlockwise disable with range: 1—3

1 clockwise enable only 2 anticlockwise enable
 only
 3 clockwise / anticlockwise enable

Pn 06 Method to stop inverter with range: 1—2

1 stop by itself 2 stop by deceleration

Pn 07 Start again by external signal with range: 1—2

1 disable 2 enable

Pn 08 Acceleration time with range: 000.01S—650.00S

Accelerate time (from 0Hz to 400Hz).

- Pn 09** Deceleration time with range: 000.01S—650.00S
Decelerate time (from 400Hz to 0Hz).
- Pn 10** Maximum runtime frequency with range: 000.10Hz—400.00Hz
Maximum output frequency by inverter.
- Pn 11** Minimum runtime frequency with range: 000.10Hz—400.00Hz
If the frequency from command below this value, inverter will stop. It wouldn't recover until command frequency up this value.
- Pn 12** Motor rating frequency with range: 010.00Hz—400.00Hz
It is used for modify the V/Fcurve.
- Pn 13** Torque compensation with range: 0.0—4.0
Large parameter may cause damage to the motor.
- Pn14** Torque compensation frequency: 0.01Hz—400.00.00Hz
Inverter doesn't provide torque compensation if runtime frequency is larger than this value.

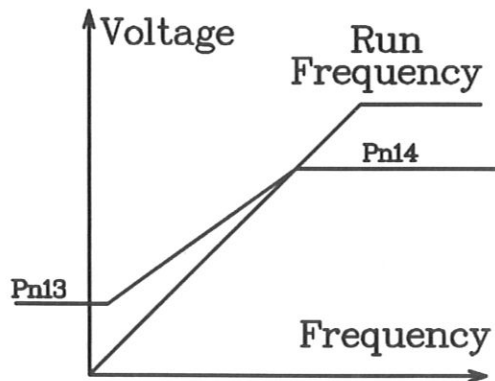

- Pn 15** Startup DC braking voltage: 1V—100V
By proper tuning of this parameter, motor can start normally from fully stop state without any difficult caused by motor's free motion and rotate direction.
- Pn 16** Startup DC braking time: 000.00S—650.00S
DC braking time before motor startup to ensure that motor is started from fully stop state.
- Pn 17** Stop DC braking voltage: 1V—100V
Braking voltage during DC braking period to ensure that motor is fully stopped in brake time.
- Pn 18** Stop DC braking time: 000.00S—650.00S
DC braking time to prevent the slide move after stopping.
- Pn 19** Source of multi-segment speed 0: 1—5
Multi-segment speed mode 0-segment frequency source:
1 Potentiometer 2 Panel button
3 External 0-5V signal 4 External 0-10V signal
5 External 0-20mA signal
- Pn 20** Multi-segment speed 1 frequency: 000.10 Hz—400.00Hz
Multi-segment speed mode 1-segment frequency
- Pn 21** Multi-segment speed 2 frequency: 000.10 Hz—400.00Hz
Multi-segment speed mode 2-segment frequency
- Pn 22** Multi-segment speed 3 frequency: 000.10 Hz—400.00Hz
Multi-segment speed mode 3-segment frequency

- Pn 23** Multi-segment speed 4 frequency: 000.10 Hz—400.00Hz
Multi-segment speed mode 4-segment frequency
- Pn 24** Multi-segment speed 5 frequency: 000.10 Hz—400.00Hz
Multi-segment speed mode 5-segment frequency
- Pn 25** Multi-segment speed 6 frequency: 000.10 Hz—400.00Hz
Multi-segment speed mode 6-segment frequency
- Pn 26** Multi-segment speed 7 frequency: 000.10 Hz—400.00Hz
Multi-segment speed mode 7-segment frequency
- Pn 27** Point move frequency: 000.10 Hz—400.00Hz
Point move frequency
- Pn 28** Choice of relay output: 1—6
1 Stop inverter 2 Run inverter
3 Inverter fault 4 Frequency increasing
5 Frequency decreasing 6 Frequency reached
If output condition is satisfied, ON/OFF states reverse.
- Pn 29** 2nd acceleration time: 000.01S—650.00S
2nd acceleration time
- Pn 30** 2nd deceleration time: 000.01S—650.00S
2nd deceleration time
- Pn 31** 2nd deceleration stop frequency: 000.10 Hz—400.00Hz
When runtime frequency is larger than this value,
acceleration/deceleration time is defined by Pn08,Pn09
When runtime frequency is smaller than this value,
acceleration/deceleration time is defined by Pn29,Pn30

As shown in Figure:

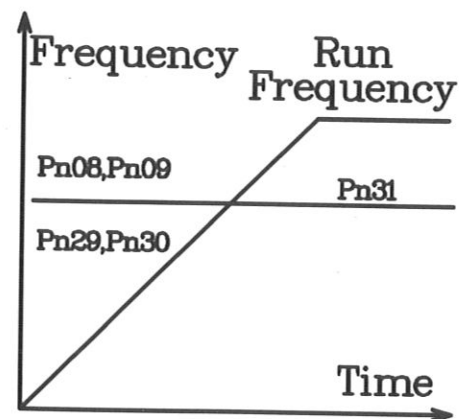

- Pn 32** Parameter management: 1—3
1 modification enable 2 modification disable
3 default value
- Pn 33** Software version
- Pn 34** Auto recover while lost power suddenly
0 disable this function
99 means do auto recover in infinite time, starting from
low frequency
Other value:
If indicator displays LU-X(any code) during
runtime

and power source recovers in 2 seconds, inverter
would start up again and reduce runtime frequency
with magnitude of under voltage time(s) multiply
frequency of this component(Hz).
The maximum power lost time is 2.5s. Beyond this time,
it would be seen as over voltage without any auto
recover.
- Pn 35** Production date

Chapter 8 Operation Examples

8.1 Operation by panel

Pn 04 = 1(Command from panel), Pn 03 = 1(Frequency from potentiometer).
Push button "RUN" on the panel, inverter starts up and running indicator is on.
Push the button again, inverter would stop.

8.2 Operation by external signal

Pn 04=2 (command from port "FWD/REV")
Pn 03=3 (frequency from port "5V")

8.3 Multi-segment speed

Pn 04=2(command from port "FWD/REV")
Pn 03=7(frequency from multi-segment 0-7)

8.4 Point move by panel

Command (Pn 04) must come from panel (=1) . Frequency (Pn 03) must be specified by button (=2) .After inverter stops, push button "←" to clockwise point move and "→" to anticlockwise point move.

8.5 Point move by external signal

Command (Pn 04) must come from port "FWD/REV" (=2) . Frequency (Pn 03) must come from external digital port (=6) . After inverter stops, connect "D0" and "JOG" to "GND" to point move clockwise, connect "D1" and "JOG" to "GND" to point move anticlockwise.

Chapter 9 Data Formation of Serial Ports

9.1 Hardware interface definition

Hardware interface type RS232 3 line



Pin definition:

- 1、 12V positive output
- 2、 Serial GND
- 3、 Data transfer pin
- 4、 Data transfer pin
- 5、 Data transfer pin
- 6、 Data transfer pin
- 7、 12V negative output
- 8、 12V negative output

Note: maximum output currenxy of 12V power is 100mA

Connection to PC:

Inverter	PC
2-----	5
3,4-----	2
5,6-----	3

9.2 Protocol

speed: 9600bps.

Data bits: 8 bits, 1 begin bit, 1 end bit, without parity

Data length sent by inverter: 13 bytes

Data length received by inverter: 9 bytes

Inverter sends data actively.

9.3 Data definition sent by inverter

1	2	3	4	5	6	7	8	9	10	11	12	13
0	5	D	D	D	D	D	D	0	0	XO	AD	F
0	5	1	2	3	4	5	6	1	0	R	D	F

Data of bit 1,2,9,10,13 is fixed.

D1—D5 data displayed on digital tube, D1 highest bit

D6 indicator data

D6.0 Fault

D6.1 Clockwise

D6.2 Anticlockwise

D6.3 Analog input

D6.4 Multi-segment

D6.5 Panel

D6.6 External signal

D6.7 Reserved

XOR: xor data of byte 2~10

ADD: sum of byte 2~11

9.4 Data definition received by inverter

1	2	3	4	5	6	7	8	9
00	55	D1	D2	D3	01	XOR	ADD	FF

Data of bit 1,2,6,9 is fixed.

D1:D2 frequency (12 ~1013)

D3 Button data

D3.0 RUN

D3.1 STOP

D3.2 up arrow

D3.3 left arrow

D3.4 right arrow

D3.5 down arrow

D3.6 SET

D3.7 change direction

XOR: xor data of byte 2~6

ADD: sum of byte 2~7

Chapter 10 Error Message and Fault Diagnosis

10.1 Fault table

Display	Meaning	Cause	Diagnosis
OU -o	Overvoltage	Overvoltage of power source	Check voltage of power source
OU -u	Acceleration overvoltage	Overvoltage of power source	Check voltage of power source
OU -d	Deceleration overvoltage	Overvoltage of power source or large inertia	Overvoltage of power source, increase deceleration time, add brake components
OU -r	Steady state Overvoltage	Overvoltage of power source	Check voltage of power source
LU -o	Stop state undervoltage	Undervoltage of power source	Check voltage of power source
LU-u	Acceleration undervoltage	Undervoltage of power source, small acceleration time	Check voltage of power source, increase acceleration time
LU -d	Deceleration undervoltage	Undervoltage of power source	Check voltage of power source
LU -r	Steady state undervoltage	Undervoltage of power source or large inertia	Check voltage of power source, decrease load
OC -o	Stop state overcurrent	Component fail, interference	Push "RESET". Component fail if it happens again.

Display	Meaning	Cause	Diagnosis
OC -u	Acceleration overcurrency	Small acceleration time or component fail	Increase acceleration time
OC -d	Deceleration overcurrency	Small deceleration time or component fail	Increase deceleration time
OC -r	Steady state overcurrency	overload or component fail	Check motor load
OT -o	Overheat while stop	High environment temperature or fail temperature sensor	Check whether air temperature is over 50, check CZ55 connection
OT -u	Overheat while acceleration	High environment temperature, small acceleration time	Check whether air temperature is over 50, increase acceleration time
OT -d	Overheat while deceleration	High environment temperature, small deceleration time	Check whether air temperature is over 50, increase deceleration time
OT -r	Overheat in steady state	High environment temperature, overload	Check whether air temperature is over 50, check overload

10.2 Other unexpected fault

- 1、 Inverter is in normal condition but without any output
 1. Internal fuse fail
 2. Internal drive module fail

Chapter 11 Maintenance and Repair

Due to the environment influence such as temperature, humidity, dust and vibration etc., and aging component, inverter may be fail at some time. So it needs periodic maintenance and repair.

Notice: please check following items before maintenance and repair. Otherwise, it may cause electronic shock.

- 1、 Power source is cut off.
- 2、 Indicator on panel is OFF.
- 3、 Maintenance is performed by professionals.

11.1 Daily maintenance and repair

Inverter must be install in the standard environment according this manual. There may be some unexpected situation during runtime. Please do daily maintenance work according following table. Keep good runtime environment, log daily data and detect fault cause in an early time. It can extend the life of inverter.

Item	Check			Criterion
	Content	Period	Method	
environment	(1) temperature, humidity (2) dust, water (3) corrosive gas	anytime	(1)thermometer, hygrometer (2)watch (3)smell	(1)temperature range -10℃ ~+40℃ (2)any mark of water (3)odor
inverter	(1)heat, vibration (2)noise	anytime	(1)touch shell (2)sound	(1) steady vibration, normal temperature (2)abnormal sound
motor	(1)heat (2)noise	anytime	(1)touch (2)sound	(1)abnormal heating (2)abnormal sound

11.2 Periodic maintenance

Inverter needs periodic maintenance every 1 or 3 month which depends on the runtime environment.

Notice: Machine maintenance or components replace must be performed by professionals. If any metal objects such screws or washer are left inside the machine, it would cause fatal damage to the inverter!

Check itmes:

- 1、 Whether the control port screws are loose or not;
- 2、 Whether the main loop port are loose or not. Or is there any sign of overheated in the line of main loop;
- 3、 Is there any trauma in power and control cable. Especially, check the robber skin in the contact with other metal;
- 4、 Is the insulation bandage of power cable loose;
- 5、 Use vacuum cleaner to clean dust on board and ventilation channel;
- 6、 If the motor needs examination, please disconnect the motor wire from inverter's U,V,W port. Otherwise, it may cause fatal damage to inverter.

Notice: Inverter has already passed the pressure test. Any improper test may cause fatal damage to inverter!

11.3 Replace the wearing parts

The wearing parts contain cooling fan and filter electrolytic capacitor whose lifetime depends on environment and load. When the temperature is 25°C, the lifetime of cooling fan is 20~40Kh and that of capacitor is 30~50Kh. User can decide when to replace these components.

1、 Cooling fan

Cause of damage: wear bearing, aging fan, heavy dust environment.

Criterion: rip in fans, abnormal vibration during runtime.

2. filter electrolytic capacitor

Cause of damage: high environment temperature, frequently load change, long-time fully load.

Criterion: liquid leak, wrong position of safety valve, capacity measurement.

10.4 Store of inverter

Precautions for storing inverter:

1、 It cannot be stored in high temperature, moist, dusty, metal dust, corrosive gas places.

2、 It will speed up the capacitor aging during long-time store. Make sure that turn on inverter once every year. The operation time cannot below 8 hours. And the input voltage increases slowly to the rating value.

10.5 Warranty

Range: inverter itself;

If any following situation happens, Isacon will provide warranty:

Any fault or damage happens during the standard use in 18 months. Beyond 18 months, Isacon will charge for the maintenance and repair;

If any following situation happens, even in 18 months, Isacon still can charge for maintenance and repair:

- a、 damage caused by wrong operation;
- b、 damage caused by voltage abnormal and nature disaster such fire and floods etc.;
- c、 apply inverter in non-standard user case.

Costs can be counted as listed on contract or actual cost.

Chapter 12 Braking Component and Capability

12.1 Regenerate Brake Resistance

There are internal regenerate brake resistance in this series inverter (from 0.75kw to 30kw). If extra brake torque is needed, please wire proper brake resistance.

Brake resistance configuration while 100% brake torque

Voltage	Power (KW)	Brake Resistance(Ω)	Brake Power (KW)
220V	0.75	200	0.1
	1.5	100	0.25
	2.2	75	0.3
	3.7	40	0.4
	5.5	30	0.5
	7.5	20	0.8
	11	15	2
	15	10	3
	18	8	4
	22	6.8	4.5
	30	5	6
	380V	0.75	400
1.5		400	0.25
2.2		250	0.3
3.7		150	0.4
5.5		100	0.5
7.5		75	0.8
11		50	2
15		40	3
18		30	4
22		30	4.5
30		20	6

Chapter 13 Type Description

13.1 Type description

A131-XXXX	with braking and communication
A131NC-XXXX	with braking, without communication
A131NB-XXXX	with communication, without braking
A131NBC-XXXX	without braking and communication

13.2 Power description

1XXX	1: input 3phase 220V, output 3phase 220V
2XXX	2: input 1phase 220V, output 3phase 220V
3XXX	3: input 3phase 380V, output 3phase 380V
5XXX	5: input 1phase 220V, output 3phase 380V
6XXX	6: input 1phase 380V, output 3phase 380V
	Remark: validate for 3phase input
8XXX	8: input 1 or 3phase 220V, output 3phase 220V

XXX	Power specification:
007	0.75kW
015	1.5kW
300	30kW