

WeMos Battery Shield V1.1.0

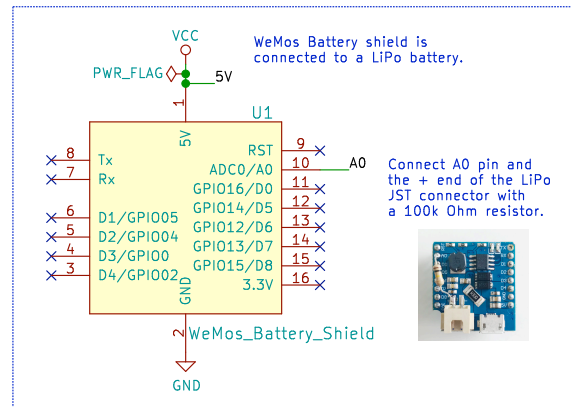

WeMos D1 Mini V3.0.0

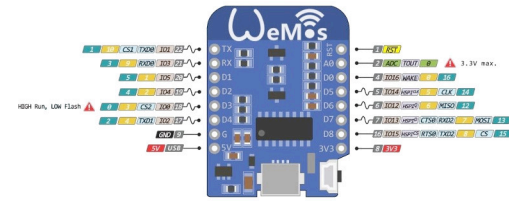
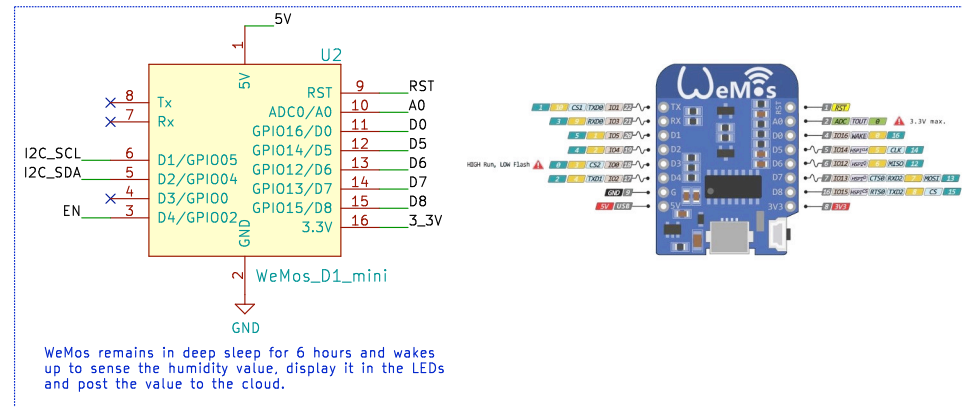

Button circuit

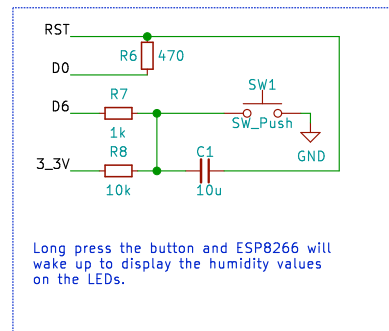

Sensor circuit

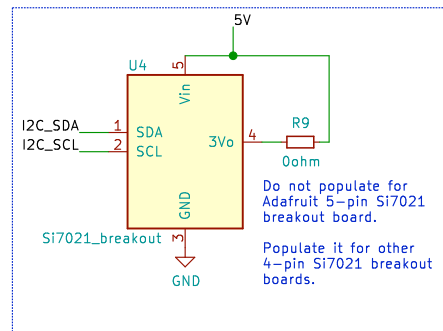

LED Circuit

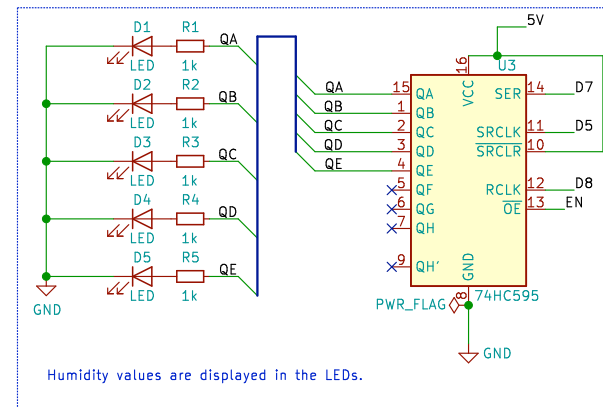

Humidity RH%	LED ON
0 - 19	all OFF
20 - 39	D1
40 - 59	D1, D2
60 - 79	D1, D2, D3
80 - 99	D1, D2, D3, D4
> 100	D1, D2, D3, D4, D5

Kitchen cupboard humidity sensor

Cactus@Hutscape

Sheet: /
File: cactus.sch

Title: Cactus

Size: A4 Date: 2019-03-27

KiCad E.D.A. kicad (5.1.0-0)

Rev: V1.0

Id: 1/1