



DUAL DIGITAL ISOLATORS

Check for Samples: [ISO7220A](#), [ISO7220B](#), [ISO7220C](#), [ISO7220M](#), [ISO7221A](#), [ISO7221B](#), [ISO7221C](#), [ISO7221M](#)

FEATURES

- 1, 5, 25, and 150-Mbps Signaling Rate Options
 - Low Channel-to-Channel Output Skew; 1 ns max
 - Low Pulse-Width Distortion (PWD); 1 ns max
 - Low Jitter Content; 1 ns Typ at 150 Mbps
- Typical 25-Year Life at Rated Voltage (see app. note [SLLA197](#) and [Figure 20](#))
- 4000- V_{PK} V_{IOTM} , 560 V_{PK} V_{IORM} per IEC 60747-5-2 (VDE 0884, Rev2)
- UL 1577, IEC 61010-1, IEC 60950-1 and CSA Approved
- 50 kV/ μ s Typical Transient Immunity
- Operates with 2.8-V (C-Grade), 3.3-V or 5-V Supplies

- 4 kV ESD Protection
- High Electromagnetic Immunity
- -40°C to 125°C Operating Range

APPLICATIONS

- Industrial Fieldbus
 - Modbus
 - Profibus™
 - DeviceNet™ Data Buses
- Computer Peripheral Interface
- Servo Control Interface
- Data Acquisition

DESCRIPTION

The ISO7220 and [ISO7221](#) are dual-channel digital isolators. To facilitate PCB layout, the channels are oriented in the same direction in the ISO7220 and in opposite directions in the ISO7221. These devices have a logic input and output buffer separated by TI's silicon-dioxide (SiO_2) isolation barrier, providing galvanic isolation of up to 4000 V_{PK} . Used in conjunction with isolated power supplies, these devices block high voltage, isolate grounds, and [prevent noise currents](#) on a data bus or other circuits from entering the local ground and interfering with or damaging sensitive circuitry.

A binary input signal is conditioned, [translated to a balanced signal](#), then differentiated by the capacitive isolation barrier. Across the isolation barrier, a differential comparator receives the logic transition information, then sets or resets a flip-flop and the output circuit accordingly. A periodic update pulse is sent across the barrier to ensure the proper dc level of the output. If this dc-refresh pulse is not received every 4 μ s, the input is assumed to be unpowered or not being actively driven, and the failsafe circuit drives the output to a logic high state.

The small capacitance and resulting time constant provide fast operation with signaling rates available from 0 Mbps (dc) to [150 Mbps](#).⁽¹⁾ The A-, B- and C-option devices have TTL input thresholds and a noise filter at the input that prevents transient pulses from being passed to the output of the device. The M-option devices have CMOS $V_{CC}/2$ input thresholds and do not have the input noise-filter and the additional propagation delay.

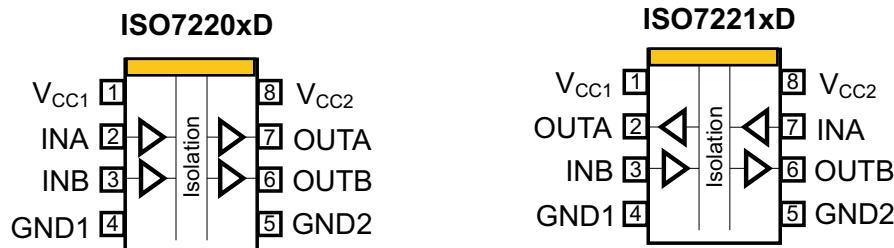

(1) The signaling rate of a line is the number of voltage transitions that are made per second expressed in the units bps (bits per second).



Please be aware that an important notice concerning availability, standard warranty, and use in critical applications of Texas Instruments semiconductor products and disclaimers thereto appears at the end of this data sheet.

DeviceNet is a trademark of Open DeviceNet Vendors Association.



These devices have limited built-in ESD protection. The leads should be shorted together or the device placed in conductive foam during storage or handling to prevent electrostatic damage to the MOS gates.

DESCRIPTION CONTINUED

These devices require two supply voltages of 2.8 V (C-Grade), 3.3 V, 5 V, or any combination. All inputs are 5-V tolerant when supplied from a 2.8-V or 3.3-V supply and all outputs are 4-mA CMOS.

These devices are characterized for operation over the ambient temperature range of -40°C to 125°C .

SINGLE-CHANNEL FUNCTION DIAGRAM

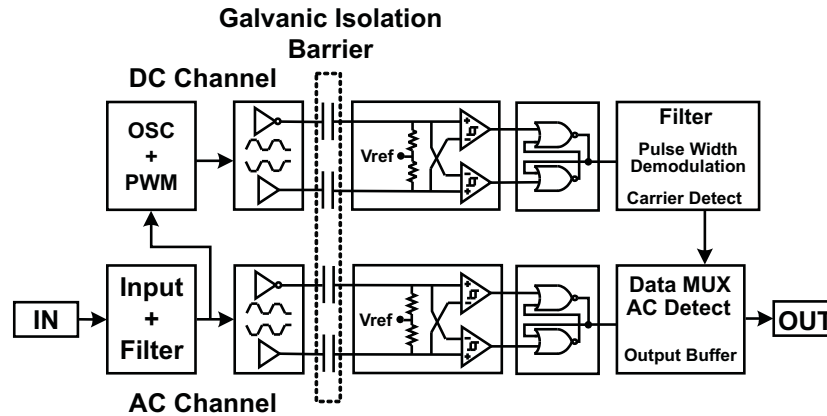

AVAILABLE OPTIONS

PRODUCT	MAX SIGNALING RATE	PACKAGE	INPUT THRESHOLD	CHANNEL DIRECTION	MARKED AS	ORDERING NUMBER
ISO7220A	1 Mbps	SOIC-8	$\approx 1.5\text{ V}$ (TTL) (CMOS compatible)	Same direction	I7220A	ISO7220AD (rail)
ISO7220B	5 Mbps	SOIC-8	$\approx 1.5\text{ V}$ (TTL) (CMOS compatible)		I7220B	ISO7220BD (rail)
ISO7220C	25 Mbps	SOIC-8	$\approx 1.5\text{ V}$ (TTL) (CMOS compatible)	I7220C	ISO7220CD (rail)	
						ISO7220CDR (reel)
ISO7220M	150 Mbps	SOIC-8	$V_{CC}/2$ (CMOS)	I7220M	ISO7220MD (rail)	
						ISO7220MDR (reel)
ISO7221A	1 Mbps	SOIC-8	$\approx 1.5\text{ V}$ (TTL) (CMOS compatible)	Opposite directions	I7221A	ISO7221AD (rail)
ISO7221B	5 Mbps	SOIC-8	$\approx 1.5\text{ V}$ (TTL) (CMOS compatible)		I7221B	ISO7221BD (rail)
ISO7221C	25 Mbps	SOIC-8	$\approx 1.5\text{ V}$ (TTL) (CMOS compatible)		I7221C	ISO7221CD (rail)
ISO7221M	150 Mbps	SOIC-8	$V_{CC}/2$ (CMOS)		I7221M	ISO7221MD (rail)

REGULATORY INFORMATION

VDE	CSA	UL
Certified according to IEC 60747-5-2	Approved under CSA Component Acceptance Notice 5A	Recognized under UL 1577 Component Recognition Program
Basic Insulation Maximum Transient Overvoltage, 4000 V _{PK} Maximum Surge Voltage, 4000 V _{PK} Maximum Working Voltage, 560 V _{PK}	Evaluated to CSA 60950-1-07 and IEC 60950-1 (2nd Ed.) for products with working voltages ≤ 125 V _{RMS} for reinforced insulation or ≤ 400 V _{RMS} for basic insulation	Single Protection, 2500 V _{RMS} ⁽¹⁾
File Number: 40016131	File Number: 220991	File Number: E181974

(1) Production tested ≥3000 V_{RMS} for 1 second in accordance with UL 1577.

ABSOLUTE MAXIMUM RATINGS⁽¹⁾

		VALUE	UNIT		
V _{CC}	Supply voltage ⁽²⁾ , V _{CC1} , V _{CC2}	–0.5 to 6	V		
V _I	Voltage at IN, OUT	–0.5 to 6	V		
I _O	Output current	±15	mA		
ESD	Electrostatic discharge	Human Body Model	All pins	±4	kV
		Field-Induced-Charged Device Model		±1	
		Machine Model		±200	V
T _J	Maximum junction temperature	170	°C		

- (1) Stresses beyond those listed under *absolute maximum ratings* may cause permanent damage to the device. These are stress ratings only and functional operation of the device at these or any other conditions beyond those indicated under *recommended operating conditions* is not implied. Exposure to absolute-maximum-rated conditions for extended periods may affect device reliability.
- (2) All voltage values except differential I/O bus voltages are with respect to network ground terminal and are peak voltage values.

RECOMMENDED OPERATING CONDITIONS

		MIN	TYP	MAX	UNIT	
V _{CC}	Supply voltage ⁽¹⁾ , V _{CC1} , V _{CC2}	ISO722xA, ISO722xB, ISO722xM	3	5.5	V	
		ISO722xC	2.8	5.5		
I _{OH}	High-level output current	–4			mA	
I _{OL}	Low-level output current			4	mA	
t _{ui}	Input pulse width ⁽²⁾	ISO722xA	1	0.67	ns	
		ISO722xB	200	100		
		ISO722xC	40	33		
		ISO722xM	6.67	5		
1/t _{ui}	Signaling rate ⁽²⁾	ISO722xA	0	1500	1000	Mbps
		ISO722xB	0	10	5	
		ISO722xC	0	30	25	
		ISO722xM	0	200	150	
V _{IH}	High-level input voltage	2		V _{CC}	V	
V _{IL}	Low-level input voltage	0		0.8	V	
V _{IH}	High-level input voltage	0.7 V _{CC}		V _{CC}	V	
V _{IL}	Low-level input voltage		0	0.3 V _{CC}	V	
T _J	Junction temperature	–40		150	°C	
H	External magnetic field-strength immunity per IEC 61000-4-8 & IEC 61000-4-9 certification			1000	A/m	

- (1) For the 5-V operation, V_{CC1} or V_{CC2} is specified from 4.5 V to 5.5 V.
For the 3.3-V operation, V_{CC1} or V_{CC2} is specified from 3 V to 3.6 V.
For the 2.8-V operation, V_{CC1} or V_{CC2} is specified at 2.8 V.
- (2) Typical signaling rate and input pulse width are measured at ideal conditions at 25°C.

ELECTRICAL CHARACTERISTICS: V_{CC1} and V_{CC2} at 5-V⁽¹⁾ OPERATION

over recommended operating conditions (unless otherwise noted)

PARAMETER		TEST CONDITIONS		MIN	TYP	MAX	UNIT
SUPPLY CURRENT							
I_{CC1}	ISO7220x	Quiescent	$V_I = V_{CC}$ or 0 V, no load		1	2	mA
	ISO7221				8.5	17	
	ISO7220A, ISO7220B	1 Mbps	0.5 MHz Input Clock Signal, no load		2	3	
	ISO7221A, ISO7221B				10	18	
	ISO7220C, ISO7220M	25 Mbps	12.5 MHz Input Clock Signal, no load		4	9	
	ISO7221C, ISO7221M				12	22	
I_{CC2}	ISO7220x	Quiescent	$V_I = V_{CC}$ or 0 V, no load		16	31	mA
	ISO7221x				8.5	17	
	ISO7220A, ISO7220B	1 Mbps	0.5 MHz Input Clock Signal, no load		17	32	
	ISO7221A, ISO7221B				10	18	
	ISO7220C, ISO7220M	25 Mbps	12.5 MHz Input Clock Signal, no load		20	34	
	ISO7221C, ISO7221M				12	22	
V_{OH}	High-level output voltage		$I_{OH} = -4$ mA, See Figure 1	$V_{CC} - 0.8$	4.6		V
			$I_{OH} = -20$ μ A, See Figure 1	$V_{CC} - 0.1$	5		
V_{OL}	Low-level output voltage		$I_{OL} = 4$ mA, See Figure 1		0.2	0.4	V
			$I_{OL} = 20$ μ A, See Figure 1		0	0.1	
$V_{I(HYS)}$	Input voltage hysteresis				150		mV
I_{IH}	High-level input current		IN from 0 V to V_{CC}			10	μ A
I_{IL}	Low-level input current				-10		
C_1	Input capacitance to ground		IN at V_{CC} , $V_I = 0.4 \sin(4E6\pi t)$		1		pF
CMTI	Common-mode transient immunity		$V_I = V_{CC}$ or 0 V, See Figure 3	25	50		kV/ μ s

(1) For the 5-V operation, V_{CC1} or V_{CC2} is specified from 4.5 V to 5.5 V.

SWITCHING CHARACTERISTICS: V_{CC1} and V_{CC2} at 5-V OPERATION

over recommended operating conditions (unless otherwise noted)

PARAMETER		TEST CONDITIONS		MIN	TYP	MAX	UNIT		
t_{pLH} , t_{pHL}	Propagation delay	ISO722xA	See Figure 1	280	405	475	ns		
	PWD			Pulse-width distortion $ t_{pHL} - t_{pLH} ^{(1)}$		1		14	
t_{pLH} , t_{pHL}	Propagation delay	ISO722xB		42	55	70			
	PWD			Pulse-width distortion $ t_{pHL} - t_{pLH} ^{(1)}$		1		3	
t_{pLH} , t_{pHL}	Propagation delay	ISO722xC		22	32	42			
	PWD			Pulse-width distortion $ t_{pHL} - t_{pLH} ^{(1)}$		1		2	
t_{pLH} , t_{pHL}	Propagation delay	ISO722xM		6	10	16			
	PWD			Pulse-width distortion $ t_{pHL} - t_{pLH} ^{(1)}$		0.5		1	
$t_{sk(pp)}$	Part-to-part skew ⁽²⁾	ISO722xA						180	ns
		ISO722xB						17	
		ISO722xC				10			
		ISO722xM				3			

(1) Also referred to as pulse skew.

(2) $t_{sk(pp)}$ is the magnitude of the difference in propagation delay times between any specified terminals of two devices when both devices operate with the same supply voltages, at the same temperature, and have identical packages and test circuits.

SWITCHING CHARACTERISTICS: V_{CC1} and V_{CC2} at 5-V OPERATION (continued)

over recommended operating conditions (unless otherwise noted)

PARAMETER		TEST CONDITIONS	MIN	TYP	MAX	UNIT
$t_{sk(o)}$	Channel-to-channel output skew ⁽³⁾	ISO722xA		3	15	ns
		ISO722xB		0.6	3	
		ISO722xC/M		0.2	1	
t_r	Output signal rise time	See Figure 1		1		ns
t_f	Output signal fall time			1		
t_{fs}	Failsafe output delay time from input power loss	See Figure 2		3		μ s
$t_{jit(pp)}$	Peak-to-peak eye-pattern jitter	ISO722xM 150 Mbps PRBS NRZ data, 5-bit max same polarity input, both channels, See Figure 4, Figure 17 150 Mbps unrestricted bit run length data input, both channels, See Figure 4		1		ns
				2		

(3) $t_{sk(o)}$ is the skew between specified outputs of a single device with all driving inputs connected together and the outputs switching in the same direction while driving identical specified loads.

ELECTRICAL CHARACTERISTICS: V_{CC1} at 5 V, V_{CC2} at 3.3 V⁽¹⁾ OPERATION

over recommended operating conditions (unless otherwise noted)

PARAMETER		TEST CONDITIONS	MIN	TYP	MAX	UNIT
SUPPLY CURRENT						
I_{CC1}	ISO7220x	Quiescent	$V_I = V_{CC}$ or 0 V, no load	1	2	mA
	ISO7221x			8.5	17	
	ISO7220A, ISO7220B	1 Mbps	0.5 MHz Input Clock Signal, no load	2	3	
	ISO7221A, ISO7221B			10	18	
	ISO7220C, ISO7220M	25 Mbps	12.5 MHz Input Clock Signal, no load	4	9	
	ISO7221C, ISO7221M			12	22	
I_{CC2}	ISO7220x	Quiescent	$V_I = V_{CC}$ or 0 V, no load	8	18	mA
	ISO7221x			4.3	9.5	
	ISO7220A, ISO7220B	1 Mbps	0.5 MHz Input Clock Signal, no load	9	19	
	ISO7221A, ISO7221B			5	11	
	ISO7220C, ISO7220M	25 Mbps	12.5 MHz Input Clock Signal, no load	10	20	
	ISO7221C, ISO7221M			6	12	
V_{OH}	High-level output voltage	ISO7220x	$I_{OH} = -4$ mA, See Figure 1	$V_{CC} - 0.4$		V
		ISO7221x (5-V side)		$V_{CC} - 0.8$		
			$I_{OH} = -20$ μ A, See Figure 1	$V_{CC} - 0.1$		
V_{OL}	Low-level output voltage		$I_{OL} = 4$ mA, See Figure 1		0.4	V
			$I_{OL} = 20$ μ A, See Figure 1		0.1	
$V_{I(HYS)}$	Input voltage hysteresis			150		mV
I_{IH}	High-level input current	IN from 0 V to V_{CC}			10	μ A
I_{IL}	Low-level input current			-10		
C_I	Input capacitance to ground	IN at V_{CC} , $V_I = 0.4 \sin(4E6\pi t)$		1		pF
CMTI	Common-mode transient immunity	$V_I = V_{CC}$ or 0 V, See Figure 3	15	40		kV/ μ s

(1) For the 5-V operation, V_{CC1} or V_{CC2} is specified from 4.5 V to 5.5 V.
For the 3.3-V operation, V_{CC1} or V_{CC2} is specified from 3 V to 3.6 V.

SWITCHING CHARACTERISTICS: V_{CC1} at 5 V, V_{CC2} at 3.3 V OPERATION

over recommended operating conditions (unless otherwise noted)

PARAMETER		TEST CONDITIONS	MIN	TYP	MAX	UNIT	
t_{pLH} , t_{pHL}	Propagation delay	See Figure 1	285	410	480	ns	
PWD	Pulse-width distortion $ t_{pHL} - t_{pLH} ^{(1)}$			1	14		
t_{pLH} , t_{pHL}	Propagation delay			45	58		75
PWD	Pulse-width distortion $ t_{pHL} - t_{pLH} ^{(1)}$			1	3		
t_{pLH} , t_{pHL}	Propagation delay			25	36		48
PWD	Pulse-width distortion $ t_{pHL} - t_{pLH} ^{(1)}$			1	2		
t_{pLH} , t_{pHL}	Propagation delay			7	12		20
PWD	Pulse-width distortion $ t_{pHL} - t_{pLH} ^{(1)}$			0.5	1		
$t_{sk(pp)}$	Part-to-part skew ⁽²⁾	ISO722xA			180		
		ISO722xB			17		
		ISO722xC			10		
		ISO722xM			5		
$t_{sk(o)}$	Channel-to-channel output skew ⁽³⁾	ISO722xA		3	15		
		ISO722xB		0.6	3		
		ISO722xC/M		0.2	1		
t_r	Output signal rise time	See Figure 1		2	ns		
t_f	Output signal fall time			2			
t_{fs}	Failsafe output delay time from input power loss	See Figure 2		3	μ s		
$t_{jit(pp)}$	Peak-to-peak eye-pattern jitter	ISO722xM	150 Mbps PRBS NRZ data, 5-bit max same polarity input, both channels, See Figure 4 , Figure 17		1	ns	
				150 Mbps unrestricted bit run length data input, both channels, See Figure 4			2

- (1) Also referred to as pulse skew.
- (2) $t_{sk(pp)}$ is the magnitude of the difference in propagation delay times between any specified terminals of two devices when both devices operate with the same supply voltages, at the same temperature, and have identical packages and test circuits.
- (3) $t_{sk(o)}$ is the skew between specified outputs of a single device with all driving inputs connected together and the outputs switching in the same direction while driving identical specified loads.

ELECTRICAL CHARACTERISTICS: V_{CC1} at 3.3 V, V_{CC2} at 5 V⁽¹⁾ OPERATION

over recommended operating conditions (unless otherwise noted)

PARAMETER		TEST CONDITIONS		MIN	TYP	MAX	UNIT
SUPPLY CURRENT							
I_{CC1}	ISO7220x	Quiescent	$V_I = V_{CC}$ or 0 V, no load		0.6	1	mA
	ISO7221x				4.3	9.5	
	ISO7220A, ISO7220B	1 Mbps	0.5 MHz Input Clock Signal, no load		1	2	
	ISO7221A, ISO7221B				5	11	
	ISO7220C, ISO7220M	25 Mbps	12.5 MHz Input Clock Signal, no load		2	4	
	ISO7221C, ISO7221M				6	12	
I_{CC2}	ISO7220x	Quiescent	$V_I = V_{CC}$ or 0 V, no load		16	31	mA
	ISO7221x				8.5	17	
	ISO7220A, ISO7220B	1 Mbps	0.5 MHz Input Clock Signal, no load		18	32	
	ISO7221A, ISO7221B				10	18	
	ISO7220C, ISO7220M	25 Mbps	12.5 MHz Input Clock Signal, no load		20	34	
	ISO7221C, ISO7221M				12	22	
V_{OH}	High-level output voltage	ISO7220x	$I_{OH} = -4$ mA, See Figure 1		$V_{CC} - 0.8$		V
		ISO7221x (3.3-V side)			$V_{CC} - 0.4$		
				$I_{OH} = -20$ μ A, See Figure 1		$V_{CC} - 0.1$	
V_{OL}	Low-level output voltage		$I_{OL} = 4$ mA, See Figure 1			0.4	V
			$I_{OL} = 20$ μ A, See Figure 1		0	0.1	
$V_{I(HYS)}$	Input threshold voltage hysteresis				150		mV
I_{IH}	High-level input current		IN from 0 V or V_{CC}			10	μ A
I_{IL}	Low-level input current				-10		
C_I	Input capacitance to ground		IN at V_{CC} , $V_I = 0.4 \sin(4E6\pi t)$		1		pF
CMTI	Common-mode transient immunity		$V_I = V_{CC}$ or 0 V, See Figure 3	15	40		kV/ μ s

- (1) For the 5-V operation, V_{CC1} or V_{CC2} is specified from 4.5 V to 5.5 V.
For the 3.3-V operation, V_{CC1} or V_{CC2} is specified from 3 V to 3.6 V.

SWITCHING CHARACTERISTICS: V_{CC1} at 3.3 V, V_{CC2} at 5 V OPERTAION

over recommended operating conditions (unless otherwise noted)

PARAMETER			TEST CONDITIONS	MIN	TYP	MAX	UNIT	
t_{pLH} , t_{pHL}	Propagation delay	ISO722xA	See Figure 1	285	395	480	ns	
PWD	Pulse-width distortion $ t_{pHL} - t_{pLH} ^{(1)}$			1	18			
t_{pLH} , t_{pHL}	Propagation delay	ISO722xB		45	58	75		
PWD	Pulse-width distortion $ t_{pHL} - t_{pLH} ^{(1)}$			1	4			
t_{pLH} , t_{pHL}	Propagation delay	ISO722xC		25	36	48		
PWD	Pulse-width distortion $ t_{pHL} - t_{pLH} ^{(1)}$			1	3			
t_{pLH} , t_{pHL}	Propagation delay	ISO722xM		7	12	21		
PWD	Pulse-width distortion $ t_{pHL} - t_{pLH} ^{(1)}$			0.5	1			
$t_{sk(pp)}$	Part-to-part skew ⁽²⁾	ISO722xA						190
		ISO722xB						17
		ISO722xC				10		
		ISO722xM				5		
$t_{sk(o)}$	Channel-to-channel output skew ⁽³⁾	ISO722xA				3	15	
		ISO722xB				0.6	3	
		ISO7220C/M				0.2	1	
t_r	Output signal rise time		See Figure 1			1		
t_f	Output signal fall time		See Figure 1			1		
t_{fs}	Failsafe output delay time from input power loss		See Figure 2			3	μ s	
$t_{jit(pp)}$	Peak-to-peak eye-pattern jitter	ISO722xM	150 Mbps PRBS NRZ data, 5-bit max same polarity input, both channels, See Figure 4 , Figure 17			1	ns	
			150 Mbps unrestricted bit run length data input, both channels, See Figure 4			2		

- (1) Also referred to as pulse skew.
- (2) $t_{sk(pp)}$ is the magnitude of the difference in propagation delay times between any specified terminals of two devices when both devices operate with the same supply voltages, at the same temperature, and have identical packages and test circuits.
- (3) $t_{sk(o)}$ is the skew between specified outputs of a single device with all driving inputs connected together and the outputs switching in the same direction while driving identical specified loads.

ELECTRICAL CHARACTERISTICS: V_{CC1} and V_{CC2} at 3.3 V⁽¹⁾ OPERATION

over recommended operating conditions (unless otherwise noted)

PARAMETER		TEST CONDITIONS		MIN	TYP	MAX	UNIT
SUPPLY CURRENT							
I_{CC1}	ISO7220x	Quiescent	$V_I = V_{CC}$ or 0 V, no load	0.6		1	mA
	ISO7221x			4.3		9.5	
	ISO7220A, ISO7220B	1 Mbps	0.5 MHz Input Clock Signal, no load	1		2	
	ISO7221A, ISO7221B			5		11	
	ISO7220C, ISO7220M	25 Mbps	12.5 MHz Input Clock Signal, no load	2		4	
	ISO7221C, ISO7221M			6		12	
	8				18		
I_{CC2}	ISO7220x	Quiescent	$V_I = V_{CC}$ or 0 V, no load	4.3		9.5	mA
	ISO7221x			9		19	
	ISO7220A, ISO7220B	1 Mbps	0.5 MHz Input Clock Signal, no load	5		11	
	ISO7221A, ISO7221B			10		20	
	ISO7220C, ISO7220M	25 Mbps	12.5 MHz Input Clock Signal, no load	6		12	
	ISO7221C, ISO7221M			6		12	
V_{OH}	High-level output voltage	$I_{OH} = -4$ mA, See Figure 1		$V_{CC} - 0.4$		3	V
		$I_{OH} = -20$ μ A, See Figure 1		$V_{CC} - 0.1$		3.3	
V_{OL}	Low-level output voltage	$I_{OL} = 4$ mA, See Figure 1			0.2	0.4	
		$I_{OL} = 20$ μ A, See Figure 1			0	0.1	
$V_{I(HYS)}$	Input voltage hysteresis				150		mV
I_{IH}	High-level input current	IN from 0 V or V_{CC}				10	μ A
I_{IL}	Low-level input current			-10			
C_I	Input capacitance to ground	IN at V_{CC} , $V_I = 0.4 \sin(4E6\pi t)$			1		pF
CMTI	Common-mode transient immunity	$V_I = V_{CC}$ or 0 V, See Figure 3		15	40		kV/ μ s

(1) For the 3.3-V operation, V_{CC1} or V_{CC2} is specified from 3 V to 3.6 V.

SWITCHING CHARACTERISTICS

V_{CC1} and V_{CC2} at 3.3 V operation, over recommended operating conditions (unless otherwise noted)

PARAMETER			TEST CONDITIONS	MIN	TYP	MAX	UNIT	
t_{pLH} , t_{pHL}	Propagation delay	ISO722xA	See Figure 1	290	400	485	ns	
PWD	Pulse-width distortion $ t_{pHL} - t_{pLH} ^{(1)}$			1	18			
t_{pLH} , t_{pHL}	Propagation delay	ISO722xB		46	62	78		
PWD	Pulse-width distortion $ t_{pHL} - t_{pLH} ^{(1)}$			1	4			
t_{pLH} , t_{pHL}	Propagation delay	ISO722xC		26	40	52		
PWD	Pulse-width distortion $ t_{pHL} - t_{pLH} ^{(1)}$			1	3			
t_{pLH} , t_{pHL}	Propagation delay	ISO722xM		8	16	25		
PWD	Pulse-width distortion $ t_{pHL} - t_{pLH} ^{(1)}$			0.5	1			
$t_{sk(pp)}$	Part-to-part skew ⁽²⁾	ISO722xA						190
		ISO722xB						17
		ISO722xC				10		
		ISO722xM				5		
$t_{sk(o)}$	Channel-to-channel output skew ⁽³⁾	ISO722xA				3	15	
		ISO722xB				0.6	3	
		ISO722xC/M				0.2	1	
t_r	Output signal rise time		See Figure 1			2		
t_f	Output signal fall time		See Figure 1			2		
t_{fs}	Failsafe output delay time from input power loss		See Figure 2			3	μ s	
$t_{jit(pp)}$	Peak-to-peak eye-pattern jitter	ISO722xM	150 Mbps PRBS NRZ data, 5-bit max same polarity input, both channels, See Figure 4 , Figure 17			1	ns	
			150 Mbps unrestricted bit run length data input, both channels, See Figure 4			2		

- (1) Also referred to as pulse skew.
- (2) $t_{sk(pp)}$ is the magnitude of the difference in propagation delay times between any specified terminals of two devices when both devices operate with the same supply voltages, at the same temperature, and have identical packages and test circuits.
- (3) $t_{sk(o)}$ is the skew between specified outputs of a single device with all driving inputs connected together and the outputs switching in the same direction while driving identical specified loads.

ELECTRICAL CHARACTERISTICS: V_{CC1} and V_{CC2} at 2.8 V (ISO722xC-only)⁽¹⁾ OPERATION

over recommended operating conditions (unless otherwise noted)

PARAMETER		TEST CONDITIONS		MIN	TYP	MAX	UNIT
SUPPLY CURRENT							
I_{CC1}	ISO7220C	Quiescent	$V_I = V_{CC}$ or 0 V, no load	0.4	0.9		mA
	ISO7221C			3.7	7.5		
	ISO7220C	25 Mbps	12.5 MHz Input Clock Signal, no load	1.5	3.5		
	ISO7221C			4.5	10		
I_{CC2}	ISO7220C	Quiescent	$V_I = V_{CC}$ or 0 V, no load	6.8	15		
	ISO7221C			3.7	7.5		
	ISO7220C	25 Mbps	12.5 MHz Input Clock Signal, no load	9	17		
	ISO7221C			4.5	10		
V_{OH}	High-level output voltage	$I_{OH} = -4$ mA, See Figure 1		$V_{CC} - 0.6$	2.55		V
		$I_{OH} = -20$ μ A, See Figure 1		$V_{CC} - 0.1$	2.8		
V_{OL}	Low-level output voltage	$I_{OL} = 4$ mA, See Figure 1		0.25	0.6		
		$I_{OL} = 20$ μ A, See Figure 1		0	0.1		
$V_{I(HYS)}$	Input voltage hysteresis			150			mV
I_{IH}	High-level input current	IN from 0 V or V_{CC}				10	μ A
I_{IL}	Low-level input current			-10			
C_I	Input capacitance to ground	IN at V_{CC} , $V_I = 0.4 \sin(4E6\pi t)$			1		pF
CMTI	Common-mode transient immunity	$V_I = V_{CC}$ or 0 V, See Figure 3		10	30		kV/ μ s

(1) 2.8-V operation is only guaranteed for ISO722xC with production screening starting in January 2012. The first two digits of the Lot Trace Code (YMSLLLLG4) written on top of each device can be used to identify year and month of production respectively.

SWITCHING CHARACTERISTICS

V_{CC1} and V_{CC2} at 2.8 V operation, over recommended operating conditions (unless otherwise noted)

PARAMETER			TEST CONDITIONS	MIN	TYP	MAX	UNIT
t_{pLH} , t_{pHL}	Propagation delay	ISO722xC	See Figure 1	26	45	65	ns
PWD	Pulse-width distortion $ t_{pHL} - t_{pLH} ^{(1)}$			1.5	5		
$t_{sk(pp)}$	Part-to-part skew ⁽²⁾	ISO722xC			12		
$t_{sk(o)}$	Channel-to-channel output skew ⁽³⁾	ISO722xC		0.2	5		
t_r	Output signal rise time		See Figure 1		2		
t_f	Output signal fall time				2		
t_{fs}	Failsafe output delay time from input power loss		See Figure 2		4.6	μ s	

- (1) Also referred to as pulse skew.
- (2) $t_{sk(pp)}$ is the magnitude of the difference in propagation delay times between any specified terminals of two devices when both devices operate with the same supply voltages, at the same temperature, and have identical packages and test circuits.
- (3) $t_{sk(o)}$ is the skew between specified outputs of a single device with all driving inputs connected together and the outputs switching in the same direction while driving identical specified loads.

PARAMETER MEASUREMENT INFORMATION

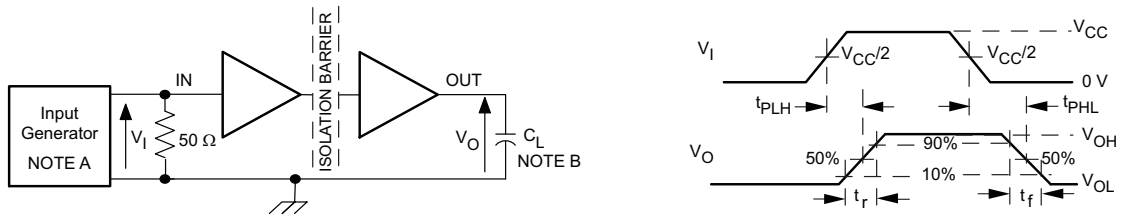

- A. The input pulse is supplied by a generator having the following characteristics: PRR ≤ 50 kHz, 50% duty cycle, $t_r \leq 3$ ns, $t_f \leq 3$ ns, $Z_O = 50\Omega$.
- B. $C_L = 15$ pF and includes instrumentation and fixture capacitance within $\pm 20\%$.

Figure 1. Switching Characteristic Test Circuit and Voltage Waveforms

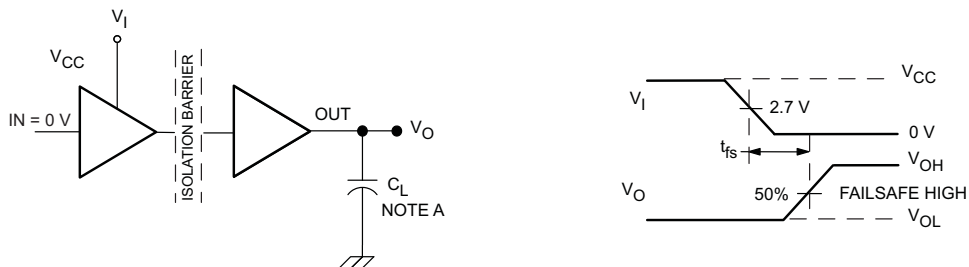

- A. $C_L = 15$ pF and includes instrumentation and fixture capacitance within $\pm 20\%$.

Figure 2. Failsafe Delay Time Test Circuit and Voltage Waveforms

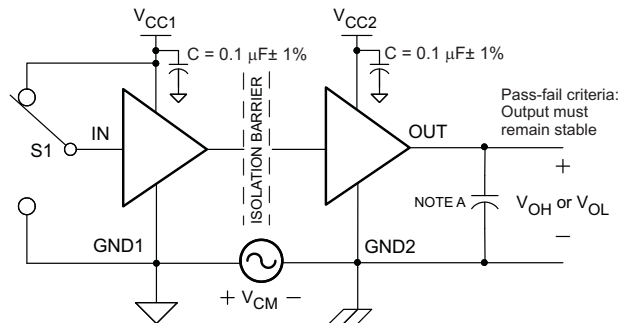

- A. $C_L = 15$ pF and includes instrumentation and fixture capacitance within $\pm 20\%$.

Figure 3. Common-Mode Transient Immunity Test Circuit

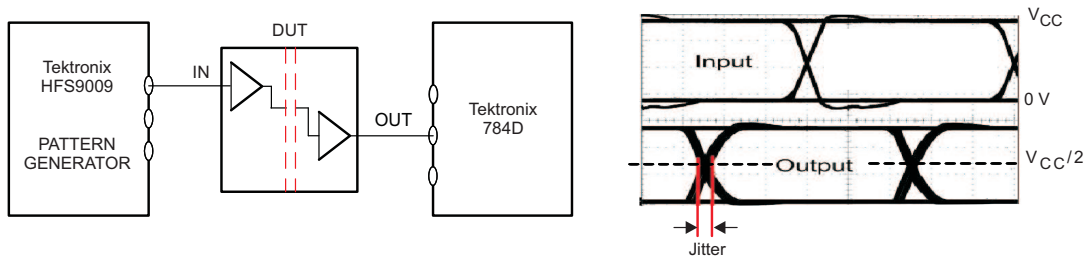

NOTE: PRBS bit pattern run length is $2^{16} - 1$. Transition time is 800 ps.

Figure 4. Peak-to-Peak Eye-Pattern Jitter Test Circuit and Voltage Waveform

DEVICE INFORMATION

IEC PACKAGE CHARACTERISTICS

PARAMETER		TEST CONDITIONS	MIN	TYP	MAX	UNIT
L(I01)	Minimum air gap (Clearance)	Shortest terminal-to-terminal distance through air	4.8			mm
L(I02)	Minimum external tracking (Creepage)	Shortest terminal-to-terminal distance across the package surface				
CTI	Tracking resistance (Comparative Tracking Index)	DIN IEC 60112 / VDE 0303 Part 1	≥400			V
	Minimum Internal Gap (Internal Clearance)	Distance through the insulation	0.008			mm
R _{IO}	Isolation resistance	Input to output, V _{IO} = 500 V, all pins on each side of the barrier tied together creating a two-terminal device, T _A < 100°C	>10 ¹²			Ω
		Input to output, V _{IO} = 500 V, 100°C ≤ T _A ≤ max	>10 ¹¹			Ω
C _{IO}	Barrier capacitance Input to output	V _I = 0.4 sin (4E6πt)		1		pF
C _I	Input capacitance to ground	V _I = 0.4 sin (4E6πt)		1		pF

NOTE: Creepage and clearance requirements should be applied according to the specific equipment isolation standards of an application. Care should be taken to maintain the creepage and clearance distance of a board design to ensure that the mounting pads of the isolator on the printed circuit board do not reduce this distance.

Creepage and clearance on a printed circuit board become equal according to the measurement techniques shown in the [Isolation Glossary](#). Techniques such as inserting grooves and/or ribs on a printed circuit board are used to help increase these specifications.

IEC 60664-1 RATINGS TABLE

PARAMETER	TEST CONDITIONS	SPECIFICATION
Basic isolation group	Material group	II
Installation classification	Rated mains voltage ≤150 V _{RMS}	I-IV
	Rated mains voltage ≤300 V _{RMS}	I-III
	Rated mains voltage ≤400 V _{RMS}	I-II

IEC 60747-5-2 INSULATION CHARACTERISTICS⁽¹⁾

PARAMETER	TEST CONDITIONS	SPECIFICATION	UNIT	
V _{IORM}	Maximum working insulation voltage	560	V _{PK}	
V _{PR}	Input to output test voltage	Method b1, V _{PR} = V _{IORM} × 1.875, 100% Production test with t = 1 s, Partial discharge <5 pC		1050
V _{IO_{TM}}	Transient overvoltage	t = 60 s		4000
R _S	Insulation resistance	V _{IO} = 500 V at T _S	>10 ⁹	Ω
	Pollution degree		2	

(1) Climatic Classification 40/125/21

DEVICE I/O SCHEMATICS

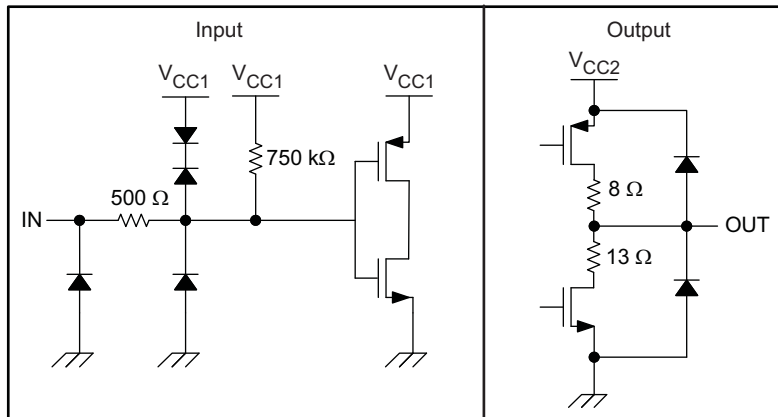

IEC SAFETY LIMITING VALUES

Safety limiting intends to prevent potential damage to the isolation barrier upon failure of input or output circuitry. A failure of the IO can allow low resistance to ground or the supply and, without current limiting, dissipate sufficient power to overheat the die and damage the isolation barrier potentially leading to secondary system failures.

PARAMETER	TEST CONDITIONS		MIN	TYP	MAX	UNIT
I _S Safety input, output, or supply current	SOIC-8	$\theta_{JA} = 212^{\circ}\text{C}/\text{W}$, $V_I = 5.5\text{ V}$, $T_J = 170^{\circ}\text{C}$, $T_A = 25^{\circ}\text{C}$			124	mA
		$\theta_{JA} = 212^{\circ}\text{C}/\text{W}$, $V_I = 3.6\text{ V}$, $T_J = 170^{\circ}\text{C}$, $T_A = 25^{\circ}\text{C}$			190	
T _S Maximum case temperature	SOIC-8				150	°C

The safety-limiting constraint is the absolute maximum junction temperature specified in the absolute maximum ratings table. The power dissipation and junction-to-air thermal impedance of the device installed in the application hardware determines the junction temperature. The assumed junction-to-air thermal resistance in the Thermal Characteristics table is that of a device installed in the JE51-3, Low Effective Thermal Conductivity Test Board for Leaded Surface Mount Packages and is conservative. The power is the recommended maximum input voltage times the current. The junction temperature is then the ambient temperature plus the power times the junction-to-air thermal resistance.

SOIC-8 PACKAGE THERMAL CHARACTERISTICS

over recommended operating conditions (unless otherwise noted)

PARAMETER		TEST CONDITIONS	MIN	TYP	MAX	UNIT
θ_{JA}	Junction-to-air	Low-K Thermal Resistance ⁽¹⁾		212		°C/W
		High-K Thermal Resistance		122		
θ_{JB}	Junction-to-Board Thermal Resistance			37		
θ_{JC}	Junction-to-Case Thermal Resistance			69.1		
P_D	Device Power Dissipation	ISO722xM $V_{CC1} = V_{CC2} = 5.5\text{ V}$, $T_J = 150^\circ\text{C}$, $C_L = 15\text{ pF}$, Input a 150 Mbps 50% duty cycle square wave			390	mW

(1) Tested in accordance with the Low-K or High-K thermal metric definitions of EIA/JESD51-3 for leaded surface mount packages.

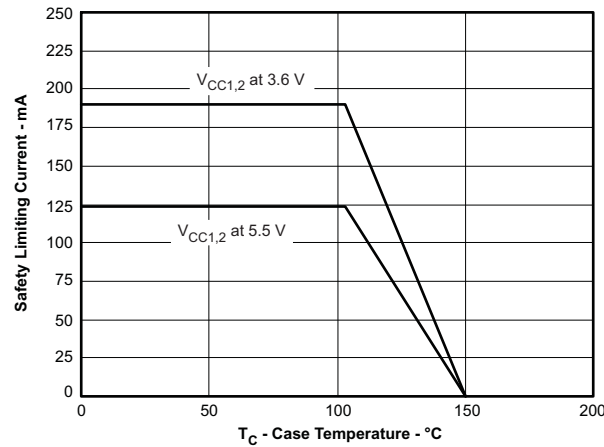

Figure 5. SOIC-8 θ_{JC} THERMAL DERATING CURVE per IEC 60747-5-2

DEVICE FUNCTION TABLE

Table 1. ISO7220x or ISO7221x⁽¹⁾

INPUT SIDE V_{CC}	OUTPUT SIDE V_{CC}	INPUT IN	OUTPUT OUT
PU	PU	H	H
		L	L
		Open	H
PD	PU	X	H

(1) PU = Powered Up ($V_{CC} \geq 3.0\text{V}$); PD = Powered Down ($V_{CC} \leq 2.5\text{V}$); X = Irrelevant; H = High Level; L = Low Level

TYPICAL CHARACTERISTIC CURVES

3.3-V RMS SUPPLY CURRENT
vs
SIGNALING RATE (Mbps)

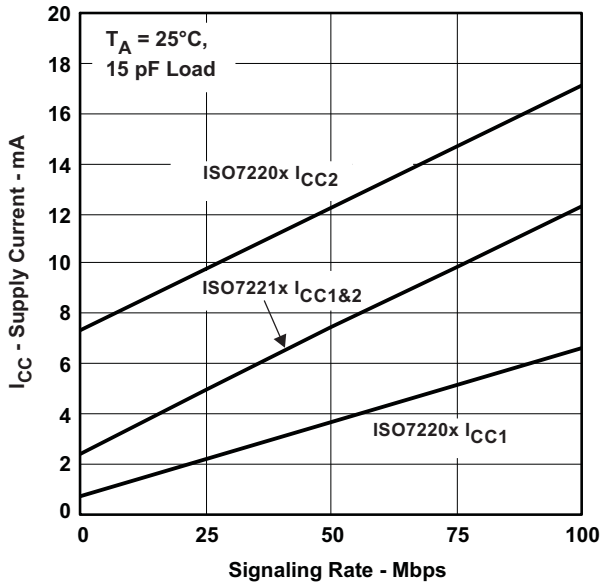

Figure 6.

5-V RMS SUPPLY CURRENT
vs
SIGNALING RATE (Mbps)

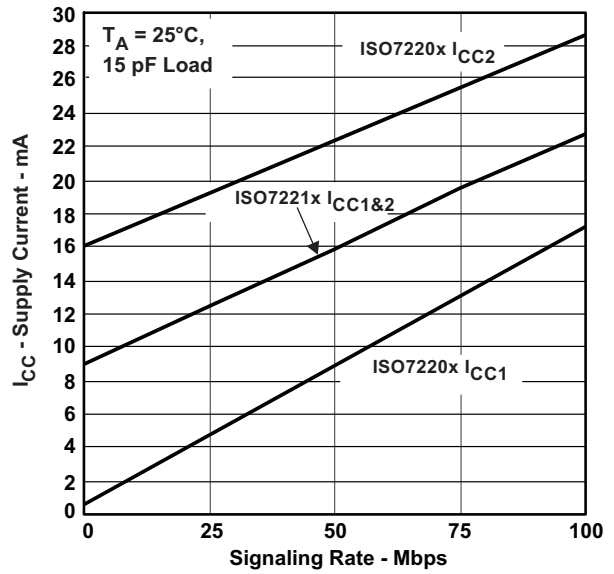

Figure 7.

PROPAGATION DELAY
vs
FREE-AIR TEMPERATURE, ISO722xA

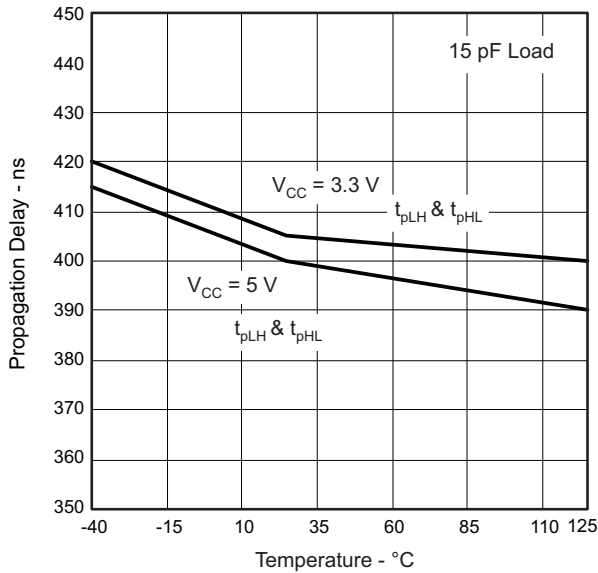

Figure 8.

PROPAGATION DELAY
vs
FREE-AIR TEMPERATURE, ISO722xB

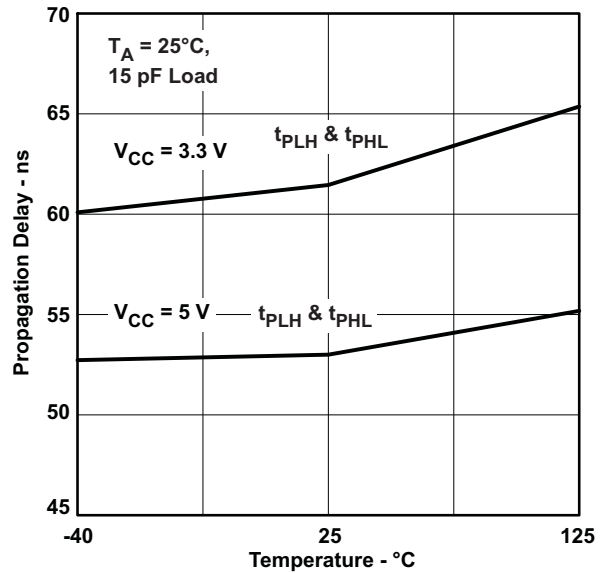

Figure 9.

TYPICAL CHARACTERISTIC CURVES (continued)

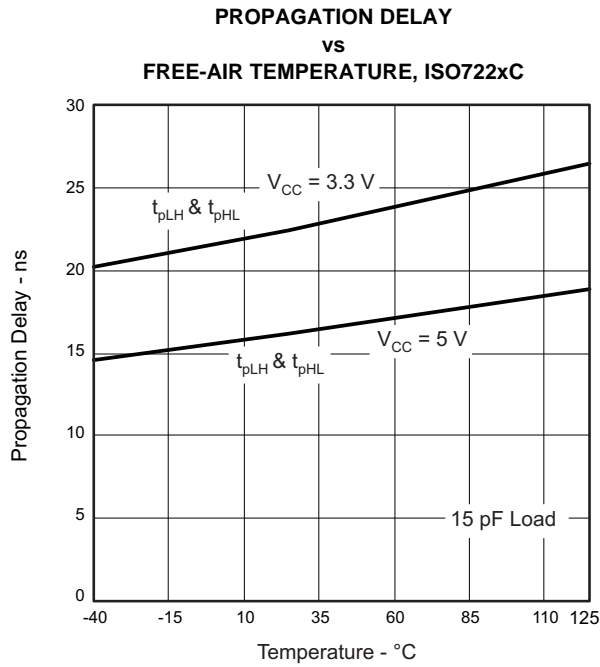

Figure 10.

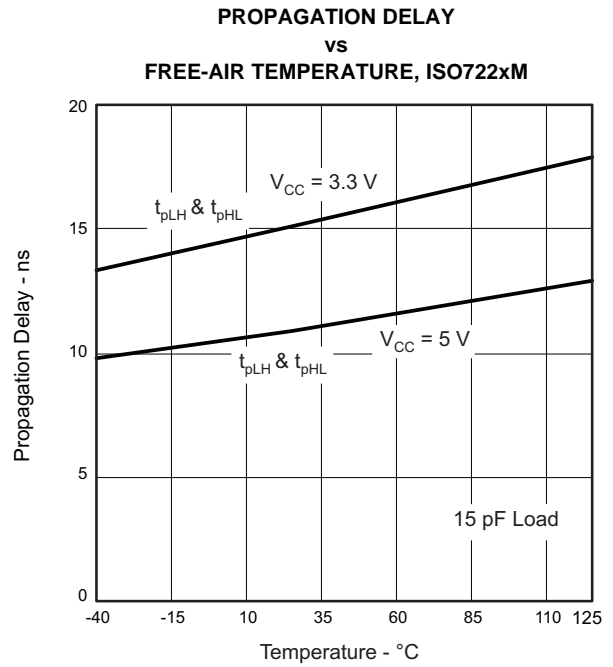

Figure 11.

ISO722xA, ISO722xB AND ISO722xC INPUT VOLTAGE LOW-TO-HIGH SWITCHING THRESHOLD

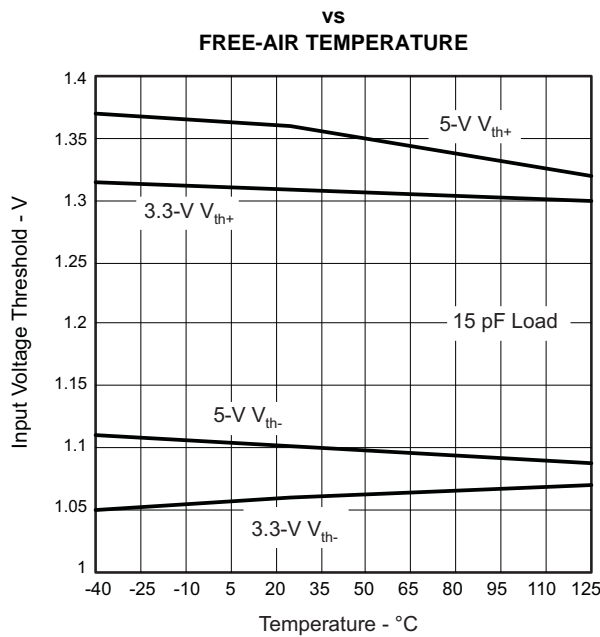

Figure 12.

ISO722xM INPUT VOLTAGE HIGH-TO-LOW SWITCHING THRESHOLD

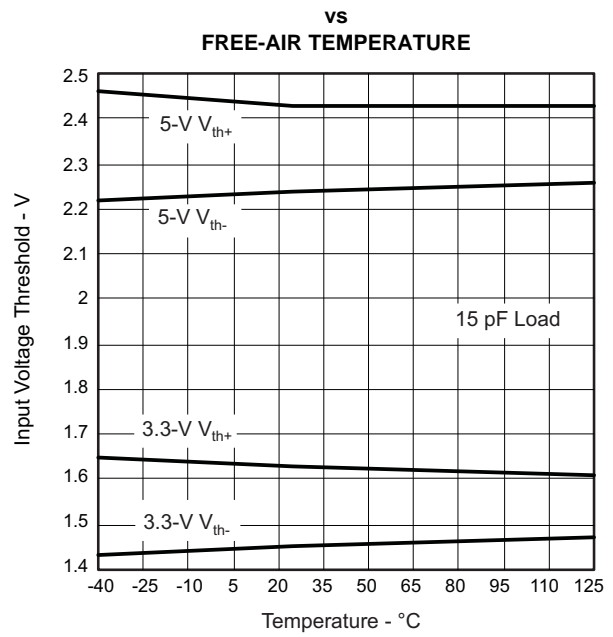

Figure 13.

TYPICAL CHARACTERISTIC CURVES (continued)

V_{CC} UNDERVOLTAGE THRESHOLD
vs
FREE-AIR TEMPERATURE

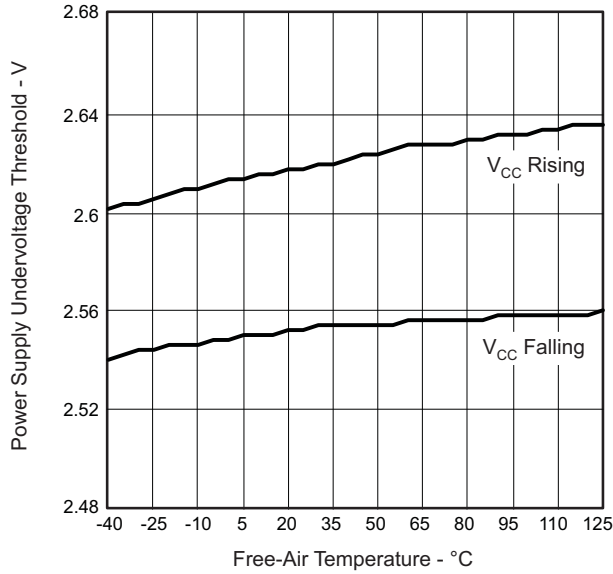

Figure 14.

HIGH-LEVEL OUTPUT CURRENT
vs
HIGH-LEVEL OUTPUT VOLTAGE

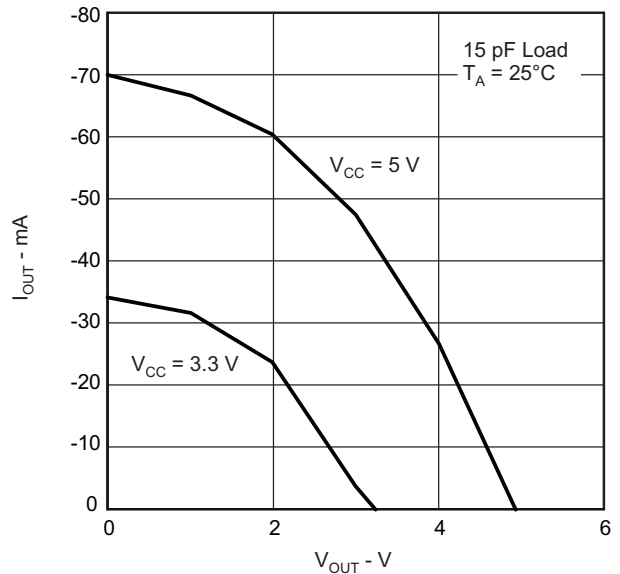

Figure 15.

LOW-LEVEL OUTPUT CURRENT
vs
LOW-LEVEL OUTPUT VOLTAGE

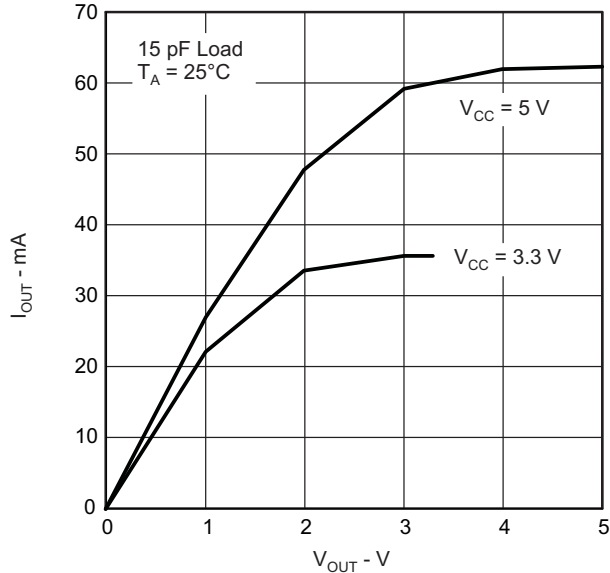

Figure 16.

ISO722xM JITTER
vs
SIGNALING RATE

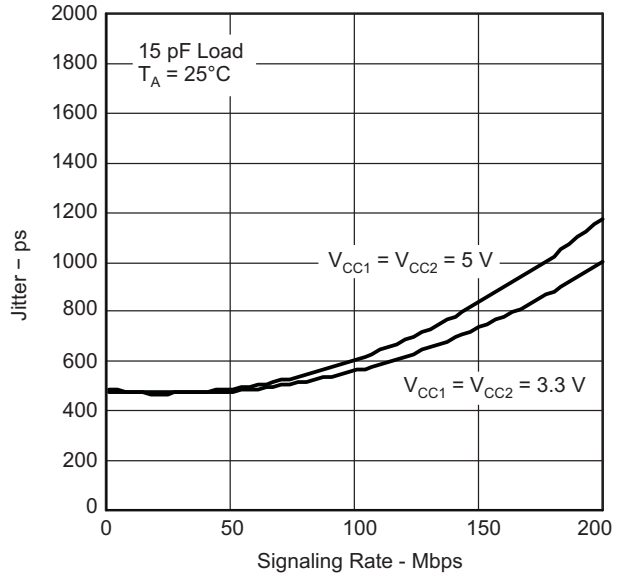

Figure 17.

APPLICATION INFORMATION

Typical Applications

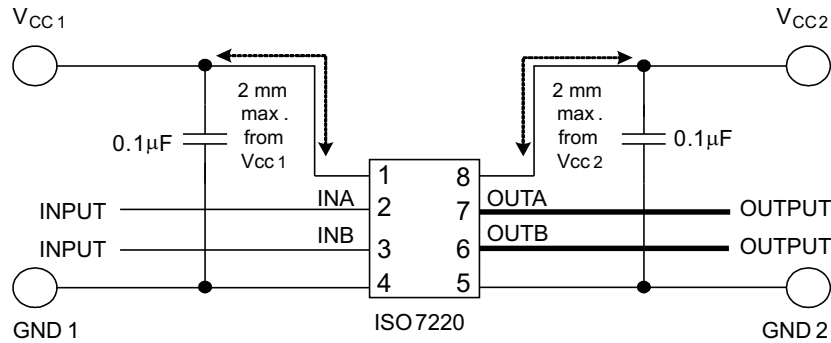

Figure 18. Typical ISO7220 Application Circuit

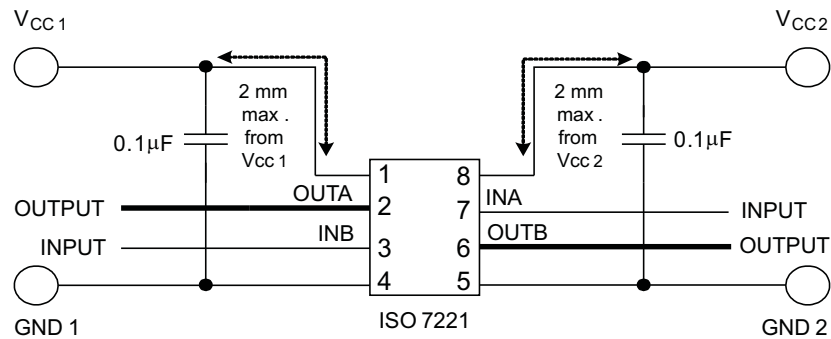

Figure 19. Typical ISO7221 Application Circuit

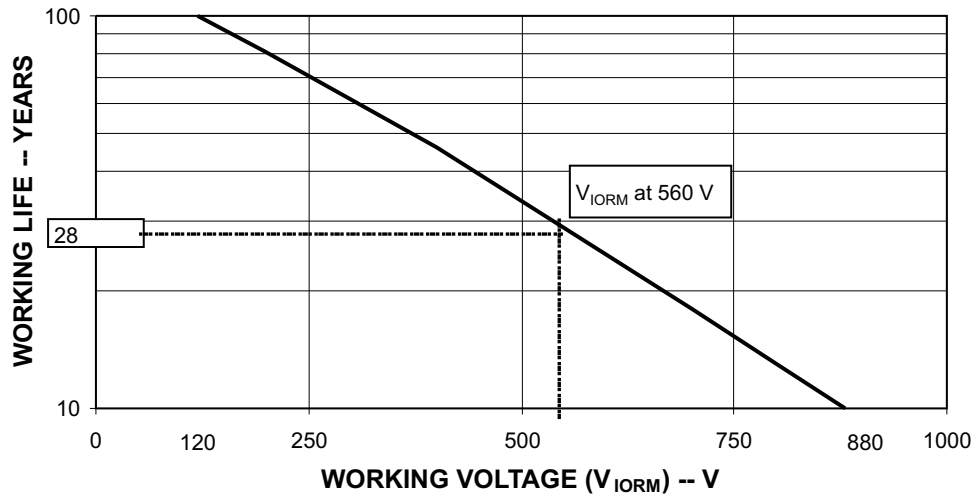
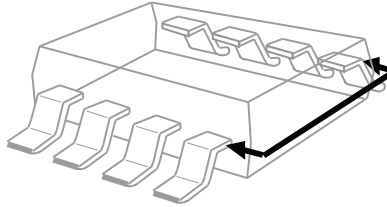

Figure 20. Time Dependent Dielectric Breakdown Test Results

ISOLATION GLOSSARY

Creepage Distance — The shortest path between two conductive input to output leads measured along the surface of the insulation. The shortest distance path is found around the end of the package body.



Clearance — The shortest distance between two conductive input to output leads measured through air (line of sight).

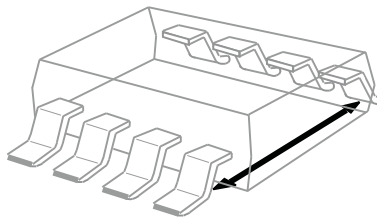

Input-to Output Barrier Capacitance — The total capacitance between all input terminals connected together, and all output terminals connected together.

Input-to Output Barrier Resistance — The total resistance between all input terminals connected together, and all output terminals connected together.

Primary Circuit — An internal circuit directly connected to an external supply mains or other equivalent source which supplies the primary circuit electric power.

Secondary Circuit — A circuit with no direct connection to primary power, and derives its power from a separate isolated source.

Comparative Tracking Index (CTI) — CTI is an index used for electrical insulating materials which is defined as the numerical value of the voltage which causes failure by tracking during standard testing. Tracking is the process that produces a partially conducting path of localized deterioration on or through the surface of an insulating material as a result of the action of electric discharges on or close to an insulation surface -- the higher CTI value of the insulating material, the smaller the minimum creepage distance.

Generally, insulation breakdown occurs either through the material, over its surface, or both. Surface failure may arise from flashover or from the progressive degradation of the insulation surface by small localized sparks. Such sparks are the result of the breaking of a surface film of conducting contaminant on the insulation. The resulting break in the leakage current produces an overvoltage at the site of the discontinuity, and an electric spark is generated. These sparks often cause carbonization on insulation material and lead to a carbon track between points of different potential. This process is known as *tracking*.

Insulation:

Operational insulation — Insulation needed for the correct operation of the equipment.

Basic insulation — Insulation to provide basic protection against electric shock.

Supplementary insulation — Independent insulation applied in addition to basic insulation in order to ensure protection against electric shock in the event of a failure of the basic insulation.

Double insulation — Insulation comprising both basic and supplementary insulation.

Reinforced insulation — A single insulation system which provides a degree of protection against electric shock equivalent to double insulation.

Pollution Degree:

Pollution Degree 1 — No pollution, or only dry, nonconductive pollution occurs. The pollution has no influence.

Pollution Degree 2 — Normally, only nonconductive pollution occurs. However, a temporary conductivity caused by condensation must be expected.

Pollution Degree 3 — Conductive pollution occurs or dry nonconductive pollution occurs which becomes conductive due to condensation which is to be expected.

Pollution Degree 4 — Continuous conductivity occurs due to conductive dust, rain, or other wet conditions.

Installation Category:

Overvoltage Category — This section is directed at insulation co-ordination by identifying the transient overvoltages which may occur, and by assigning 4 different levels as indicated in IEC 60664.

I: Signal Level — Special equipment or parts of equipment.

II: Local Level — Portable equipment etc.

III: Distribution Level — Fixed installation

IV: Primary Supply Level — Overhead lines, cable systems

Each category should be subject to smaller transients than the category above.

REVISION HISTORY

Changes from Original (July 2006) to Revision A	Page
• Deleted "and CSA Apporved" from the UL 1577 FEATURES bullet	1
• Added option A to the AVAILABLE OPTIONS table	2

Changes from Revision A (August 2006) to Revision B	Page
• Added the ELECTRICAL CHARACTERISTICS tables to the data sheet	3
• Added the PARAMETER MEASUREMENT INFORMATION to the data sheet	13
• Added the DEVICE INFORMATION section to the data sheet	14
• Added the TYPICAL CHARACTERISTIC CURVES to the data sheet	17
• Added the APPLICATION INFORMATION section to the data sheet	20
• Added the ISOLATION GLOSSARY section to the data sheet	21

Changes from Revision B (May 2007) to Revision C	Page
• Added the Signaling rate values to the RECOMMENDED OPERATING CONDITIONS table	3
• Added Figure 17 cross reference to the Peak-to-peak eye-pattern jitter of the SWITCHING CHARACTERISTICS table	5
• Added Figure 17 cross reference to the Peak-to-peak eye-pattern jitter of the SWITCHING CHARACTERISTICS table	6
• Added Figure 17 cross reference to the Peak-to-peak eye-pattern jitter of the SWITCHING CHARACTERISTICS table	8
• Added Figure 17 cross reference to the Peak-to-peak eye-pattern jitter of the SWITCHING CHARACTERISTICS table	10
• Changed the IEC 60664-1 RATINGS TABLE - Specification I-III test conditions From: Rated mains voltage ≤150 VRMS To: Rated mains voltage ≤300 VRMS. Added a row for the I-II specifications	14
• Added Figure 20 - Time Dependent Dielectric Breakdown Test Results	20

Changes from Revision C (May 2007) to Revision D	Page
• Changed Figure 18 - Pin 2 (INA) label From: OUTPUT to INPUT	20

Changes from Revision D (June 2007) to Revision E	Page
• Changed Figure 6 - New Curves	17
• Changed Figure 7 - Re-scaled the Y-axis	17

Changes from Revision E (July 2007) to Revision F	Page
• Added $t_{sk(pp)}$ footnote to the SWITCHING CHARACTERISTICS: V_{CC1} and V_{CC2} at 5-V OPERATION table	4
• Added $t_{sk(o)}$ footnote to the SWITCHING CHARACTERISTICS: V_{CC1} and V_{CC2} at 5-V OPERATION table	5
• Added $t_{sk(pp)}$ footnote to the SWITCHING CHARACTERISTICS: V_{CC1} at 5 V, V_{CC2} at 3.3 V OPERATION table	6
• Added $t_{sk(o)}$ footnote to the SWITCHING CHARACTERISTICS: V_{CC1} at 5 V, V_{CC2} at 3.3 V OPERATION table	6
• Added $t_{sk(pp)}$ footnote to the SWITCHING CHARACTERISTICS: V_{CC1} at 3.3 V, V_{CC2} at 5 V OPERATION table	8
• Added $t_{sk(o)}$ footnote to the SWITCHING CHARACTERISTICS: V_{CC1} at 3.3 V, V_{CC2} at 5 V OPERATION table	8
• Added $t_{sk(pp)}$ footnote to the SWITCHING CHARACTERISTICS table	10
• Added $t_{sk(o)}$ footnote to the SWITCHING CHARACTERISTICS table	10
• Changed Figure 6 - Re-scaled the Y-axis	17
• Changed Figure 7 - New Curves	17

Changes from Revision F (August 2007) to Revision G	Page
• Added Part Numbers ISO7220B and ISO7221B to the data sheet	1
• Added 5-Mbps Signaling rate to the FEATURES list	1
• Added Part Numbers ISO720B and ISO7221B to the AVAILABLE OPTIONS table	2
• Added Part Numbers ISO720B and ISO7221B to the ELECTRICAL CHARACTERISTICS: V_{CC1} and V_{CC2} at 5-V table	4
• Added Part Numbers ISO720B and ISO7221B to the ELECTRICAL CHARACTERISTICS: V_{CC1} at 5 V, V_{CC2} at 3.3 V table	5
• Added Part Numbers ISO720B and ISO7221B to the ELECTRICAL CHARACTERISTICS: V_{CC1} at 3.3 V, V_{CC2} at 5 V table	7
• Added Part Numbers ISO720B and ISO7221B to the ELECTRICAL CHARACTERISTICS: V_{CC1} and V_{CC2} at 3.3 V	9
• Added PROPAGATION DELAY vs FREE-AIR TEMPERATURE, ISO722xB, Figure 9	17

Changes from Revision G (March 2008) to Revision H	Page
• Added Note: (1) to the RECOMMENDED OPERATING CONDITIONS table	3
• Added Note: (1) to the ELECTRICAL CHARACTERISTICS: V_{CC1} and V_{CC2} at 5-V table	4
• Added Note: (1) to the ELECTRICAL CHARACTERISTICS: V_{CC1} at 5 V, V_{CC2} at 3.3 V table	5
• Added Note (1): to the ELECTRICAL CHARACTERISTICS: V_{CC1} at 3.3 V, V_{CC2} at 5 V table	7
• Added Note (1): to the ELECTRICAL CHARACTERISTICS: V_{CC1} and V_{CC2} at 3.3 V	9

Changes from Revision H (May 2008) to Revision I	Page
• Added "IEC 61010-1, IEC 60950-1 and CSA Approved" to the UL 1577 FEATURES bullet	1

Changes from Revision I (December 2008) to Revision J	Page
• Changed ISO7221C Marked As column From: TI7221C To: I7221C in the AVAILABLE OPTIONS table	2

Changes from Revision J (May 2009) to Revision K	Page
• Changed column 2 of the AVAILABLE OPTIONS table From: Signaling Rate To: Max Signaling Rate	2
• Changed the the RECOMMENDED OPERATING CONDITIONS so that Note (2) is associated with all device options in the Input pulse width and Signaling rate	3
• Changed Note (2) From: Typical signaling rate under ideal conditions at 25°C. To: Typical signaling rate and Input pulse width are measured at ideal conditions at 25°C.	3

Changes from Revision K (January 2010) to Revision L	Page
• Changed Feature From: 4000- V_{peak} Isolation, 560 V_{peak} V_{IORM} To: 4000- V_{PK} V_{IOTM} , 560 V_{PK} V_{IORM} per IEC 60747-5-2 (VDE 0884, Rev2)	1
• Changed Feature From: Operates with 3.3-V or 5-V Supplies To: Operates with 2.8-V (C-Grade), 3.3-V or 5-V Supplies	1
• Changed the REGULATORY INFORMATION table	3
• Added device options to V_{CC} in the RECOMMENDED OPERATING CONDITIONS table	3
• Changed Note: (1) in the RECOMMENDED OPERATING CONDITIONS table	3
• Changed I_{CC1} and I_{CC2} test conditions in the 5-V table	4
• Changed Table Note: (1)	4
• Changed I_{CC1} and I_{CC2} test conditions in the V_{CC1} at 5 V, V_{CC2} at 3.3 V table	5
• Changed Table Note: (1)	5
• Changed I_{CC1} and I_{CC2} test conditions in the V_{CC1} at 3.3 V, V_{CC2} at 5 V table	7
• Changed Table Note (1)	7
• Changed I_{CC1} and I_{CC2} test conditions in the V_{CC1} and V_{CC2} at 3.3 V table	9
• Changed Table Note (1)	9
• Added ELECTRICAL and Switching CHARACTERISTICS table for V_{CC1} and V_{CC2} at 2.8 V (ISO722xC-only)	11
• Changed Figure 2	13
• Changed the CTI MIN value From: ≥ 175 V To: ≥ 400 V	14
• Changed Figure 14	19

PACKAGING INFORMATION

Orderable Device	Status (1)	Package Type	Package Drawing	Pins	Package Qty	Eco Plan (2)	Lead/Ball Finish	MSL Peak Temp (3)	Op Temp (°C)	Top-Side Markings (4)	Samples
ISO7220AD	ACTIVE	SOIC	D	8	75	Green (RoHS & no Sb/Br)	CU NIPDAU	Level-1-260C-UNLIM	-40 to 125	I7220A	Samples
ISO7220ADG4	ACTIVE	SOIC	D	8	75	Green (RoHS & no Sb/Br)	CU NIPDAU	Level-1-260C-UNLIM	-40 to 125	I7220A	Samples
ISO7220ADR	ACTIVE	SOIC	D	8	2500	Green (RoHS & no Sb/Br)	CU NIPDAU	Level-1-260C-UNLIM	-40 to 125	I7220A	Samples
ISO7220ADRG4	ACTIVE	SOIC	D	8	2500	Green (RoHS & no Sb/Br)	CU NIPDAU	Level-1-260C-UNLIM	-40 to 125	I7220A	Samples
ISO7220BD	ACTIVE	SOIC	D	8	75	Green (RoHS & no Sb/Br)	CU NIPDAU	Level-1-260C-UNLIM	-40 to 125	I7220B	Samples
ISO7220BDG4	ACTIVE	SOIC	D	8	75	Green (RoHS & no Sb/Br)	CU NIPDAU	Level-1-260C-UNLIM	-40 to 125	I7220B	Samples
ISO7220BDR	ACTIVE	SOIC	D	8	2500	Green (RoHS & no Sb/Br)	CU NIPDAU	Level-1-260C-UNLIM	-40 to 125	I7220B	Samples
ISO7220BDRG4	ACTIVE	SOIC	D	8	2500	Green (RoHS & no Sb/Br)	CU NIPDAU	Level-1-260C-UNLIM	-40 to 125	I7220B	Samples
ISO7220CD	ACTIVE	SOIC	D	8	75	Green (RoHS & no Sb/Br)	CU NIPDAU	Level-1-260C-UNLIM	-40 to 125	I7220C	Samples
ISO7220CDG4	ACTIVE	SOIC	D	8	75	Green (RoHS & no Sb/Br)	CU NIPDAU	Level-1-260C-UNLIM	-40 to 125	I7220C	Samples
ISO7220CDR	ACTIVE	SOIC	D	8	2500	Green (RoHS & no Sb/Br)	CU NIPDAU	Level-1-260C-UNLIM	-40 to 125	I7220C	Samples
ISO7220CDRG4	ACTIVE	SOIC	D	8	2500	Green (RoHS & no Sb/Br)	CU NIPDAU	Level-1-260C-UNLIM	-40 to 125	I7220C	Samples
ISO7220MD	ACTIVE	SOIC	D	8	75	Green (RoHS & no Sb/Br)	CU NIPDAU	Level-1-260C-UNLIM	-40 to 125	I7220M	Samples
ISO7220MDG4	ACTIVE	SOIC	D	8	75	Green (RoHS & no Sb/Br)	CU NIPDAU	Level-1-260C-UNLIM	-40 to 125	I7220M	Samples
ISO7220MDR	ACTIVE	SOIC	D	8	2500	Green (RoHS & no Sb/Br)	CU NIPDAU	Level-1-260C-UNLIM	-40 to 125	I7220M	Samples
ISO7220MDRG4	ACTIVE	SOIC	D	8	2500	Green (RoHS & no Sb/Br)	CU NIPDAU	Level-1-260C-UNLIM	-40 to 125	I7220M	Samples
ISO7221AD	ACTIVE	SOIC	D	8	75	Green (RoHS & no Sb/Br)	CU NIPDAU	Level-1-260C-UNLIM	-40 to 125	I7221A	Samples

Orderable Device	Status (1)	Package Type	Package Drawing	Pins	Package Qty	Eco Plan (2)	Lead/Ball Finish	MSL Peak Temp (3)	Op Temp (°C)	Top-Side Markings (4)	Samples
ISO7221ADG4	ACTIVE	SOIC	D	8	75	Green (RoHS & no Sb/Br)	CU NIPDAU	Level-1-260C-UNLIM	-40 to 125	I7221A	Samples
ISO7221ADR	ACTIVE	SOIC	D	8	2500	Green (RoHS & no Sb/Br)	CU NIPDAU	Level-1-260C-UNLIM	-40 to 125	I7221A	Samples
ISO7221ADRG4	ACTIVE	SOIC	D	8	2500	Green (RoHS & no Sb/Br)	CU NIPDAU	Level-1-260C-UNLIM	-40 to 125	I7221A	Samples
ISO7221BD	ACTIVE	SOIC	D	8	75	Green (RoHS & no Sb/Br)	CU NIPDAU	Level-1-260C-UNLIM	-40 to 125	I7221B	Samples
ISO7221BDG4	ACTIVE	SOIC	D	8	75	Green (RoHS & no Sb/Br)	CU NIPDAU	Level-1-260C-UNLIM	-40 to 125	I7221B	Samples
ISO7221BDR	ACTIVE	SOIC	D	8	2500	Green (RoHS & no Sb/Br)	CU NIPDAU	Level-1-260C-UNLIM	-40 to 125	I7221B	Samples
ISO7221BDRG4	ACTIVE	SOIC	D	8	2500	Green (RoHS & no Sb/Br)	CU NIPDAU	Level-1-260C-UNLIM	-40 to 125	I7221B	Samples
ISO7221CD	ACTIVE	SOIC	D	8	75	Green (RoHS & no Sb/Br)	CU NIPDAU	Level-1-260C-UNLIM	-40 to 125	I7221C	Samples
ISO7221CDG4	ACTIVE	SOIC	D	8	75	Green (RoHS & no Sb/Br)	CU NIPDAU	Level-1-260C-UNLIM	-40 to 125	I7221C	Samples
ISO7221CDR	ACTIVE	SOIC	D	8	2500	Green (RoHS & no Sb/Br)	CU NIPDAU	Level-1-260C-UNLIM	-40 to 125	I7221C	Samples
ISO7221CDRG4	ACTIVE	SOIC	D	8	2500	Green (RoHS & no Sb/Br)	CU NIPDAU	Level-1-260C-UNLIM	-40 to 125	I7221C	Samples
ISO7221MD	ACTIVE	SOIC	D	8	75	Green (RoHS & no Sb/Br)	CU NIPDAU	Level-1-260C-UNLIM	-40 to 125	I7221M	Samples
ISO7221MDG4	ACTIVE	SOIC	D	8	75	Green (RoHS & no Sb/Br)	CU NIPDAU	Level-1-260C-UNLIM	-40 to 125	I7221M	Samples
ISO7221MDR	ACTIVE	SOIC	D	8	2500	Green (RoHS & no Sb/Br)	CU NIPDAU	Level-1-260C-UNLIM	-40 to 125	I7221M	Samples
ISO7221MDRG4	ACTIVE	SOIC	D	8	2500	Green (RoHS & no Sb/Br)	CU NIPDAU	Level-1-260C-UNLIM	-40 to 125	I7221M	Samples

(1) The marketing status values are defined as follows:

ACTIVE: Product device recommended for new designs.

LIFEBUY: TI has announced that the device will be discontinued, and a lifetime-buy period is in effect.

NRND: Not recommended for new designs. Device is in production to support existing customers, but TI does not recommend using this part in a new design.

PREVIEW: Device has been announced but is not in production. Samples may or may not be available.

OBSELETE: TI has discontinued the production of the device.

(2) Eco Plan - The planned eco-friendly classification: Pb-Free (RoHS), Pb-Free (RoHS Exempt), or Green (RoHS & no Sb/Br) - please check <http://www.ti.com/productcontent> for the latest availability information and additional product content details.

TBD: The Pb-Free/Green conversion plan has not been defined.

Pb-Free (RoHS): TI's terms "Lead-Free" or "Pb-Free" mean semiconductor products that are compatible with the current RoHS requirements for all 6 substances, including the requirement that lead not exceed 0.1% by weight in homogeneous materials. Where designed to be soldered at high temperatures, TI Pb-Free products are suitable for use in specified lead-free processes.

Pb-Free (RoHS Exempt): This component has a RoHS exemption for either 1) lead-based flip-chip solder bumps used between the die and package, or 2) lead-based die adhesive used between the die and leadframe. The component is otherwise considered Pb-Free (RoHS compatible) as defined above.

Green (RoHS & no Sb/Br): TI defines "Green" to mean Pb-Free (RoHS compatible), and free of Bromine (Br) and Antimony (Sb) based flame retardants (Br or Sb do not exceed 0.1% by weight in homogeneous material)

(3) MSL, Peak Temp. -- The Moisture Sensitivity Level rating according to the JEDEC industry standard classifications, and peak solder temperature.

(4) Multiple Top-Side Markings will be inside parentheses. Only one Top-Side Marking contained in parentheses and separated by a "~" will appear on a device. If a line is indented then it is a continuation of the previous line and the two combined represent the entire Top-Side Marking for that device.

Important Information and Disclaimer: The information provided on this page represents TI's knowledge and belief as of the date that it is provided. TI bases its knowledge and belief on information provided by third parties, and makes no representation or warranty as to the accuracy of such information. Efforts are underway to better integrate information from third parties. TI has taken and continues to take reasonable steps to provide representative and accurate information but may not have conducted destructive testing or chemical analysis on incoming materials and chemicals. TI and TI suppliers consider certain information to be proprietary, and thus CAS numbers and other limited information may not be available for release.

In no event shall TI's liability arising out of such information exceed the total purchase price of the TI part(s) at issue in this document sold by TI to Customer on an annual basis.

OTHER QUALIFIED VERSIONS OF ISO7220A, ISO7221A, ISO7221C :

- Automotive: [ISO7220A-Q1](#), [ISO7221A-Q1](#), [ISO7221C-Q1](#)

NOTE: Qualified Version Definitions:

- Automotive - Q100 devices qualified for high-reliability automotive applications targeting zero defects

TAPE AND REEL INFORMATION



QUADRANT ASSIGNMENTS FOR PIN 1 ORIENTATION IN TAPE



*All dimensions are nominal

Device	Package Type	Package Drawing	Pins	SPQ	Reel Diameter (mm)	Reel Width W1 (mm)	A0 (mm)	B0 (mm)	K0 (mm)	P1 (mm)	W (mm)	Pin1 Quadrant
ISO7220ADR	SOIC	D	8	2500	330.0	12.4	6.4	5.2	2.1	8.0	12.0	Q1
ISO7220BDR	SOIC	D	8	2500	330.0	12.4	6.4	5.2	2.1	8.0	12.0	Q1
ISO7220CDR	SOIC	D	8	2500	330.0	12.4	6.4	5.2	2.1	8.0	12.0	Q1
ISO7220MDR	SOIC	D	8	2500	330.0	12.4	6.4	5.2	2.1	8.0	12.0	Q1
ISO7221ADR	SOIC	D	8	2500	330.0	12.4	6.4	5.2	2.1	8.0	12.0	Q1
ISO7221BDR	SOIC	D	8	2500	330.0	12.4	6.4	5.2	2.1	8.0	12.0	Q1
ISO7221CDR	SOIC	D	8	2500	330.0	12.4	6.4	5.2	2.1	8.0	12.0	Q1
ISO7221MDR	SOIC	D	8	2500	330.0	12.4	6.4	5.2	2.1	8.0	12.0	Q1

TAPE AND REEL BOX DIMENSIONS

*All dimensions are nominal

Device	Package Type	Package Drawing	Pins	SPQ	Length (mm)	Width (mm)	Height (mm)
ISO7220ADR	SOIC	D	8	2500	367.0	367.0	35.0
ISO7220BDR	SOIC	D	8	2500	367.0	367.0	35.0
ISO7220CDR	SOIC	D	8	2500	367.0	367.0	35.0
ISO7220MDR	SOIC	D	8	2500	367.0	367.0	35.0
ISO7221ADR	SOIC	D	8	2500	367.0	367.0	35.0
ISO7221BDR	SOIC	D	8	2500	367.0	367.0	35.0
ISO7221CDR	SOIC	D	8	2500	367.0	367.0	35.0
ISO7221MDR	SOIC	D	8	2500	367.0	367.0	35.0

D (R-PDSO-G8)

PLASTIC SMALL OUTLINE

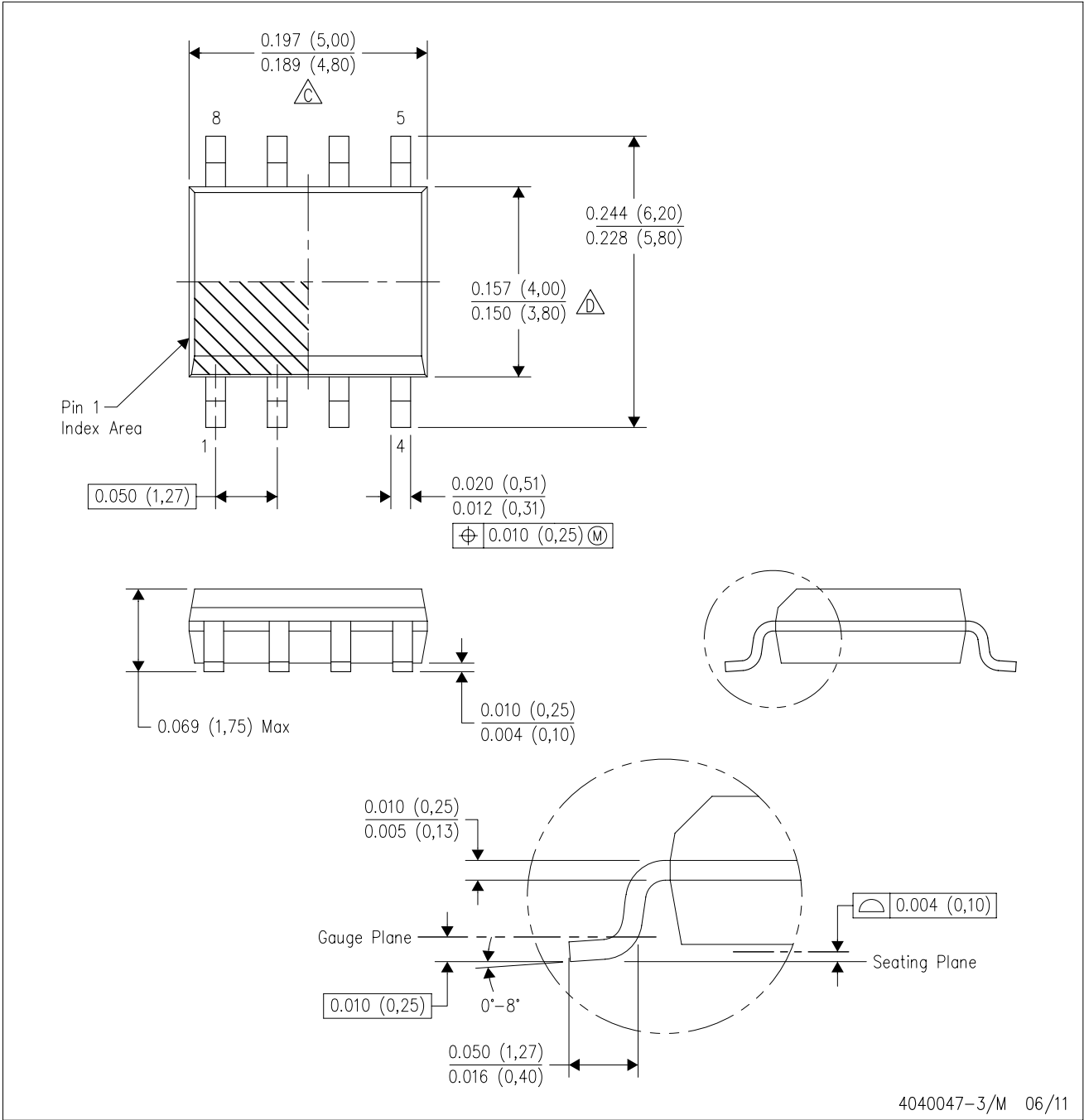

- NOTES:
- A. All linear dimensions are in inches (millimeters).
 - B. This drawing is subject to change without notice.
 - Body length does not include mold flash, protrusions, or gate burrs. Mold flash, protrusions, or gate burrs shall not exceed 0.006 (0,15) each side.
 - Body width does not include interlead flash. Interlead flash shall not exceed 0.017 (0,43) each side.
 - E. Reference JEDEC MS-012 variation AA.

D (R-PDSO-G8)

PLASTIC SMALL OUTLINE



- NOTES:
- All linear dimensions are in millimeters.
 - This drawing is subject to change without notice.
 - Publication IPC-7351 is recommended for alternate designs.
 - Laser cutting apertures with trapezoidal walls and also rounding corners will offer better paste release. Customers should contact their board assembly site for stencil design recommendations. Refer to IPC-7525 for other stencil recommendations.
 - Customers should contact their board fabrication site for solder mask tolerances between and around signal pads.

IMPORTANT NOTICE

Texas Instruments Incorporated and its subsidiaries (TI) reserve the right to make corrections, enhancements, improvements and other changes to its semiconductor products and services per JESD46, latest issue, and to discontinue any product or service per JESD48, latest issue. Buyers should obtain the latest relevant information before placing orders and should verify that such information is current and complete. All semiconductor products (also referred to herein as "components") are sold subject to TI's terms and conditions of sale supplied at the time of order acknowledgment.

TI warrants performance of its components to the specifications applicable at the time of sale, in accordance with the warranty in TI's terms and conditions of sale of semiconductor products. Testing and other quality control techniques are used to the extent TI deems necessary to support this warranty. Except where mandated by applicable law, testing of all parameters of each component is not necessarily performed.

TI assumes no liability for applications assistance or the design of Buyers' products. Buyers are responsible for their products and applications using TI components. To minimize the risks associated with Buyers' products and applications, Buyers should provide adequate design and operating safeguards.

TI does not warrant or represent that any license, either express or implied, is granted under any patent right, copyright, mask work right, or other intellectual property right relating to any combination, machine, or process in which TI components or services are used. Information published by TI regarding third-party products or services does not constitute a license to use such products or services or a warranty or endorsement thereof. Use of such information may require a license from a third party under the patents or other intellectual property of the third party, or a license from TI under the patents or other intellectual property of TI.

Reproduction of significant portions of TI information in TI data books or data sheets is permissible only if reproduction is without alteration and is accompanied by all associated warranties, conditions, limitations, and notices. TI is not responsible or liable for such altered documentation. Information of third parties may be subject to additional restrictions.

Resale of TI components or services with statements different from or beyond the parameters stated by TI for that component or service voids all express and any implied warranties for the associated TI component or service and is an unfair and deceptive business practice. TI is not responsible or liable for any such statements.

Buyer acknowledges and agrees that it is solely responsible for compliance with all legal, regulatory and safety-related requirements concerning its products, and any use of TI components in its applications, notwithstanding any applications-related information or support that may be provided by TI. Buyer represents and agrees that it has all the necessary expertise to create and implement safeguards which anticipate dangerous consequences of failures, monitor failures and their consequences, lessen the likelihood of failures that might cause harm and take appropriate remedial actions. Buyer will fully indemnify TI and its representatives against any damages arising out of the use of any TI components in safety-critical applications.

In some cases, TI components may be promoted specifically to facilitate safety-related applications. With such components, TI's goal is to help enable customers to design and create their own end-product solutions that meet applicable functional safety standards and requirements. Nonetheless, such components are subject to these terms.

No TI components are authorized for use in FDA Class III (or similar life-critical medical equipment) unless authorized officers of the parties have executed a special agreement specifically governing such use.

Only those TI components which TI has specifically designated as military grade or "enhanced plastic" are designed and intended for use in military/aerospace applications or environments. Buyer acknowledges and agrees that any military or aerospace use of TI components which have **not** been so designated is solely at the Buyer's risk, and that Buyer is solely responsible for compliance with all legal and regulatory requirements in connection with such use.

TI has specifically designated certain components as meeting ISO/TS16949 requirements, mainly for automotive use. In any case of use of non-designated products, TI will not be responsible for any failure to meet ISO/TS16949.

Products

Audio	www.ti.com/audio
Amplifiers	amplifier.ti.com
Data Converters	dataconverter.ti.com
DLP® Products	www.dlp.com
DSP	dsp.ti.com
Clocks and Timers	www.ti.com/clocks
Interface	interface.ti.com
Logic	logic.ti.com
Power Mgmt	power.ti.com
Microcontrollers	microcontroller.ti.com
RFID	www.ti-rfid.com
OMAP Applications Processors	www.ti.com/omap
Wireless Connectivity	www.ti.com/wirelessconnectivity

Applications

Automotive and Transportation	www.ti.com/automotive
Communications and Telecom	www.ti.com/communications
Computers and Peripherals	www.ti.com/computers
Consumer Electronics	www.ti.com/consumer-apps
Energy and Lighting	www.ti.com/energy
Industrial	www.ti.com/industrial
Medical	www.ti.com/medical
Security	www.ti.com/security
Space, Avionics and Defense	www.ti.com/space-avionics-defense
Video and Imaging	www.ti.com/video

TI E2E Community

e2e.ti.com