

Dtto Modular Robot v2.0 – Schematics

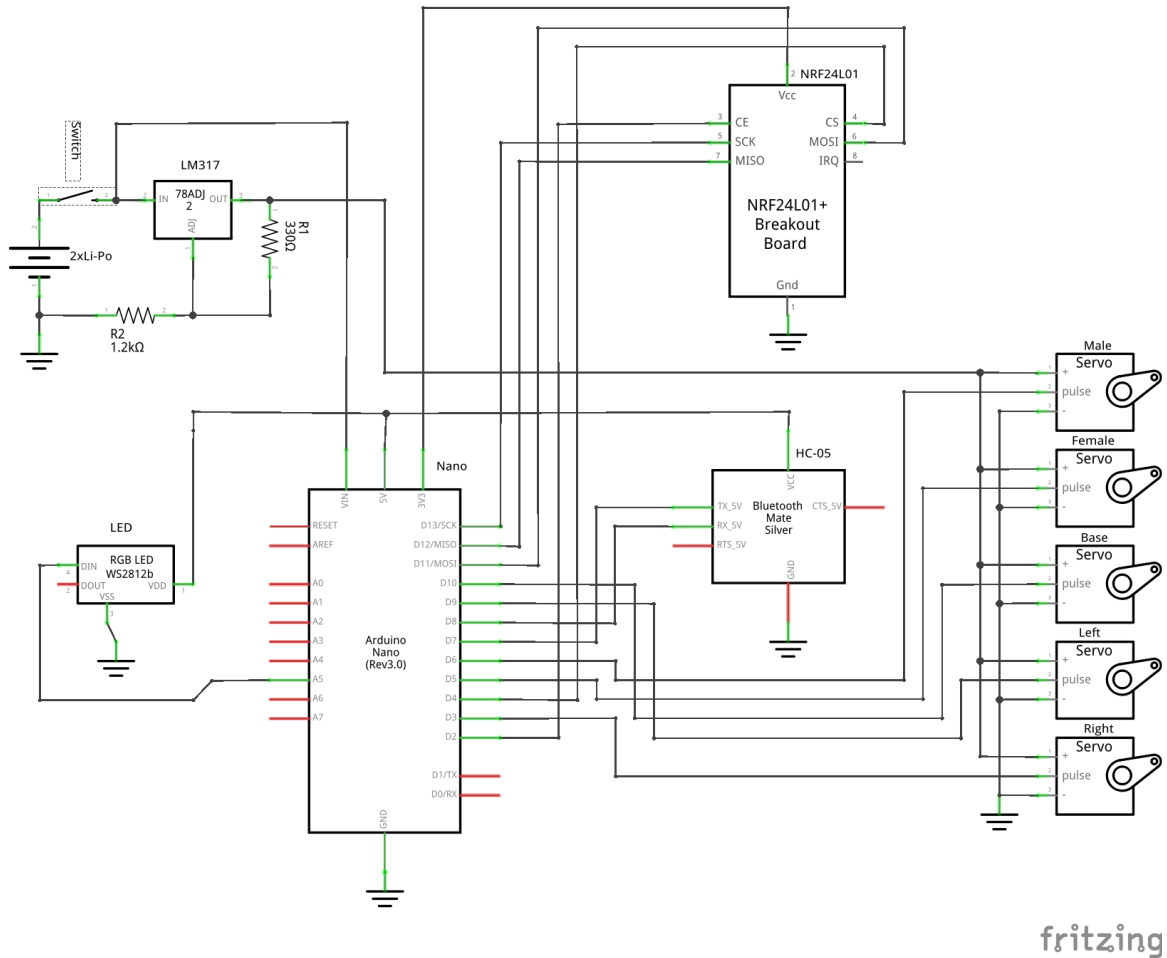

Project at:

<https://hackaday.io/project/9976-dtto-v20-modular-robot>

<https://github.com/otreb333/Dtto-Modular-Robot>

<https://www.youtube.com/playlist?list=PLoFHruvLOzZ8lMCxhqWBXichj1xdftpl1>

This project and all of its files, images and texts are entirely licensed under the CC BY-SA 4.0 license. (<http://creativecommons.org/licenses/by-sa/4.0/legalcode>)